

TRASMAN

DESIGNED & MADE IN
100%
BARCELONA

MANUAL DE MONTAJE
NOTICE DE MONTAGE - ASSEMBLY MANUAL
MONTAGEANLEITUNG - MANUAL DE
MONTAGEM - MONTAGE INSTRUCTIES
MONTÁŽNÍ NÁVOD
تعليمات التجميع:

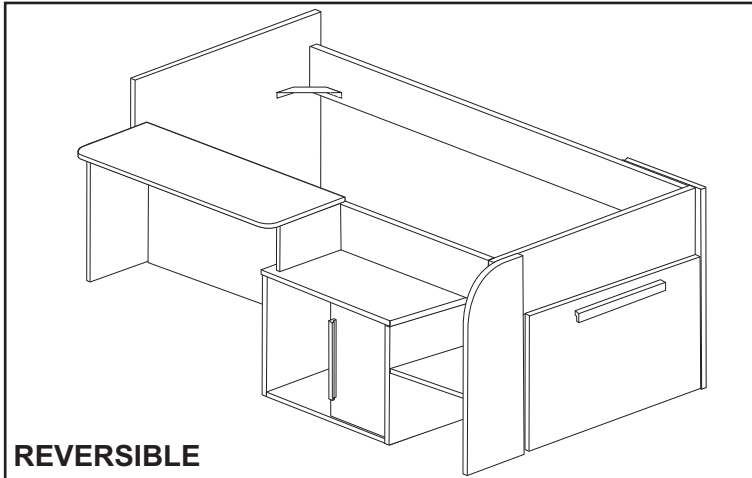

REVERSIBLE

1960 SACHA

V.01 - 05/23



≈ 2h



x2

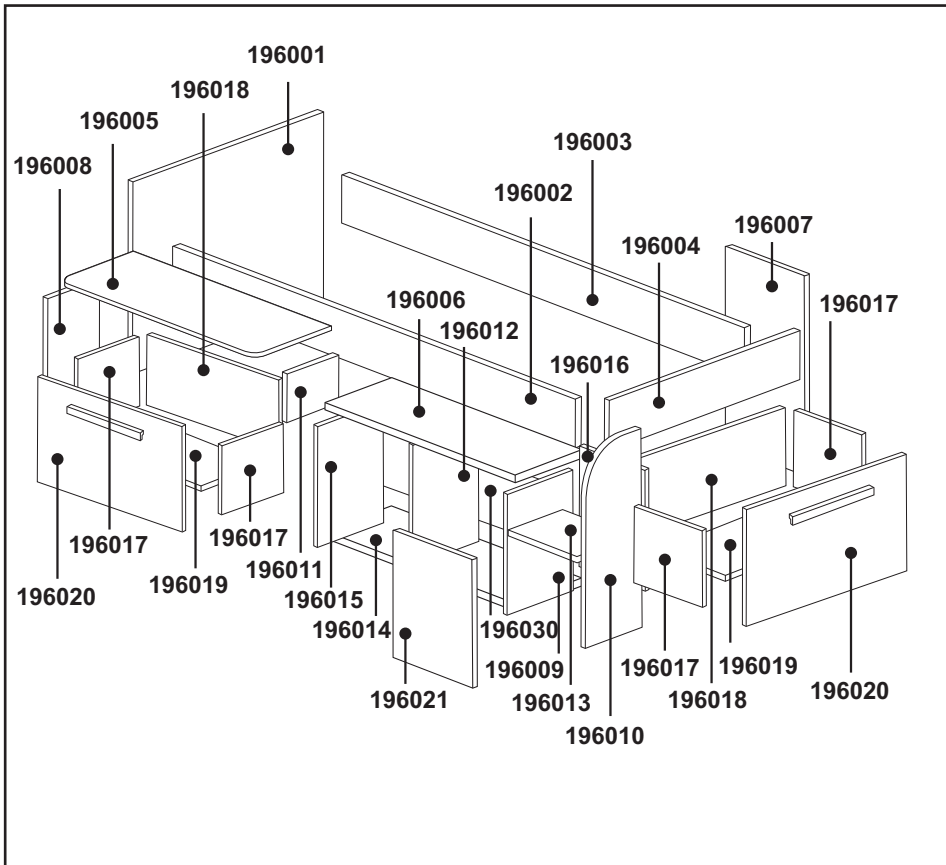
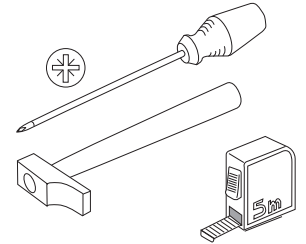

ANTES DE EMPEZAR CONSULTE LOS
CONSEJOS PARA EL MONTAJE.

AVANT DE COMMENCER
CONSULTEZ LES INSTRUCTIONS DE
MONTAGE.

BEFORE STARTING REFER TO THE
ASSEMBLY ADVICE.

VOR DEM BEGINN EMPFIEHLT ES
SICH AUFMERKSAM DIE HINWEISE
ZUR MONTAGE ZU LESEN.

ANTES DE COMEÇAR CONSULTE OS
CONSELHOS PARA A MONTAGEM.

RAADPLEEG VOORDAT U BEGINT
HET MONTAGE-ADVIES.

PRED ZACÁNÍM SE PROSÍM
MONTÁŽNÍ PORADENSTVÍ

اقرأ تعليمات التجميع بعناية.

x8 TM660A	x8 TUEM61013	x18 PE845	x18 EX16	x12 TSM	x26 CL830	x4 SKM16	x4 TCK0311	x6 CL1060	x28 TA550	x1 LLA3	x4 TP3540	x2 TM630A	x2 CM670	x4 TV3135	x44 TP3515	x3 AAM220		
x2 TA760	x1 LLA4	x2 TP3530	x4 TP4016	x8 RTC24	x1 COLA	x30 P1030	x1 CT715	x2 E2137	x2 B35SA	x2 BA35S	x10 TA3RK	x8 TE17RK	x2 TA4RK	x2 T8BL	x4 ESJ	x22 TA3BL	x10 TE17BL	x6 T10RK

ESPAÑOL

CONSEJOS PARA EL MONTAJE:

- 1-ESTUDIE ATENTAMENTE EL MANUAL DE MONTAJE.
- 2-LOCALICE LAS PIEZAS QUE CONSTITUYEN SU MUEBLE.
- 3-REUNA Y CONTROLE LOS HERRAJES SUMINISTRADOS.
- 4-EQUIPESE CON LAS HERRAMIENTAS NECESARIAS.
- 5-PREPARE UNA ZONA DE MONTAJE.

CONSEJOS PARA EL MANTENIMIENTO:

- 1-QUITAR EL POLVO CUIDADOSAMENTE.
- 2-HUMEDECER UN PAÑO SUAVE Y LIMPIO CON AGUA LIGERAMENTE ENJABONADA.

NO FUERCE NUNCA EN LAS UNIONES APRIETE LOS TORNILLOS DESPUES DE CIERTO TIEMPO DE UTILIZACION. CONSERVE SU MANUAL DE MONTAJE.SI FALTARA UNA PIEZA SERIA LA MANERA MAS FACIL DE COMUNICARLO A LA TIENDA.

NO USE NUNCA PRODUCTOS ABRASIVOS TALES COMO: LANA DE ACERO , LIJAS,DISOLVENTES,ETC. NO MOJAR NI SOMETER A GRANDES HUMEDADES AL MUEBLE.

FRANCAIS

INSTRUCTIONS DE MONTAGE:

- 1-LISEZ ATTENTIVEMENT LA NOTICE DE MONTAGE.
- 2-REPEREZ LES PIECES QUI COMPOSENT VOTRE MEUBLE.
- 3-REGROUPEZ ET VERIFIEZ LES FERRURES FOURNIES.
- 4-DOTEZ-VOUS DES OUTILS NECESSAIRES.
- 5-PREPAREZ UN ESPACE DE MONTAGE.

CONSEILS D'ENTRETIEN:

- 1-ENLEVEZ SOIGNEUSEMENT LA POUSSIERE.
- 2-HUMIDIFIEZ UN CHIFFON DOUX ET PROPRE AVEC DE L'EAU LEGEREMENT SAVONNEUSE.

LES MEUBLES CONTENANT DES PANNEAUX À BASE DE BOIS (PANNEAUX DE PARTICULES, PANNEAUX DE FIBRES, CONTREPLAQUÉ...) PEUVENT ÉMETTRE DES SUBSTANCES POLLUANTES DANS L'AIR INTÉRIEUR. IL EST AINSI RECOMMANDÉ, APRÈS L'INSTALLATION DU MEUBLE DANS SON LOGEMENT, D'AÉRER FRÉQUEMMENT LA PIÈCE CONCERNÉE PENDANT AU MOINS QUATRE SEMAINES AFIN DE RÉDUIRE SON EXPOSITION AUX POLLUANTS ÉMIS PAR LE MEUBLE.

NE FORCEZ JAMAIS LES RACCORDS. RESSERREZ LES VIS APRES UN CERTAIN TEMPS D'UTILISATION. CONSERVEZ LA NOTICE DE MONTAGE.EN CAS DE PIECE MANQUANTE , CE SERA LE MEILLEUR MOYEN D'EN INFORMER LE MAGASIN.

N'UTILISEZ JAMAIS DES PRODUITS ABRASIFS COMME DE LA LAINE D'ACIER, DU PAPIER DE VERRE, DES SOLVANTS, ETC. NE MOUILLEZ PAS LE MEUBLE ET EVITEZ TOUTE ESPOSITION A UNE HUMIDITE IMPORTANTE.

ENGLISH

ASSEMBLY ADVICE:

- 1- STUDY THE ASSEMBLY MANUAL CAREFULLY.
- 2- LOCATE THE PARTS THAT COMPRISE YOUR FURNITURE ITEM.
- 3- ORGANISE AND CHECK THE FITTINGS SUPPLIED.
- 4- HAVE THE NECESSARY TOOLS TO HAND.
- 5- PREPARE AN ASSEMBLY AREA.

MAINTENANCE ADVICE:

- 1- REMOVE DUST CAREFULLY.
- 2- MOISTEN A SOFT, CLEAN CLOTH WITH SLIGHTLY SOAPY WATER.

DO NOT FORCE ANY OF THE JOINTS. TIGHTEN THE SCREWS AFTER HAVING USED THE FURNITURE FOR SOME TIME. KEEP YOUR ASSEMBLY MANUAL. IF ANY PART IS MISSING, IT WILL HELP YOU TO LET THE SHOP KNOW.

NEVER USE ABRASIVE PRODUCTS SUCH AS STEEL WOOL, SANDPAPER, ETC. DO NOT WET THE FURNITURE OR KEEP IT IN A VERY DAMP PLACE.

DEUTSCH

HINWEISE ZUR MONTAGE:

- 1- LESEN SIE AUFMERKSAM DIE MONTAGEANLEITUNG DURCH.
- 2- LOKALISIEREN SIE DIE ZUM MÖBEL GEHÖRENDE TEILE.
- 3- KONTROLLIEREN SIE DIE MITGELIEFERTEN WERKZEUGE.
- 4- RÜSTEN SIE SICH MIT DEN ZUSÄTZLICH BENÖTIGTEN WERKZEUGEN AUS.
- 5- BEREITEN SIE EINEN PLATZ FÜR DIE MONTAGE VOR.

HINWEISE ZUR PFLEGE:

- 1- ENTFERNEN SIE UMSICHTIG DEN ANGESAMMELTEN STAUB.
- 2- VERWENDEN SIE EIN WEICHES UND SAUBERES TUCH UND SCHWACHE SEIFENLAUGE.

FORCIEREN SIE NIEMALS DIE VERBINDUNGEN. ZIEHEN SIE DIE SCHRAUBEN NACH EINER BESTIMMTEN NUTZUNGSZEIT NACH. BEWAHREN SIE DIE MONTAGEANLEITUNG AUF. SOLLTE EIN TEIL FEHLEN IST SIE VON GROSSER WICHTIGKEIT BEI DER NACHBESTELLUNG IM LADEN.

VERWENDEN SIE NIEMALS SCHEUERENDE PRODUKTE WIE STAHLWOLLE, SCHMIRGELPAPIER, LÖSUNGSMITTEL UND DERGL. WASSER UND HOHE FEUCHTIGKEIT SIND SCHÄDLICH FÜR DAS MÖBEL.

POTUGUES

CONSELHO PARA A MONTAGEM :

- 1 - ESTUDE ATENTAMENTE O MANUAL DE MONTAGEM.
- 2 - LOCALIZE AS PEÇAS QUE CONSTITUEM O SEU MÓVEL.
- 3 - REUNA E CONTROLE AS FERRAGENS FORNECIDAS.
- 4 - EQUIPE-SE COM AS FERRAMENTAS NECESSÁRIAS.
- 5 - PREPARE UMA ZONA DE MONTAGEM.

CONSELHOS PARA A MANUTENÇÃO :

- 1- RETIRAR A POEIRA COM CUIDADO.
- 2 - HUMEDECER UM PANO SUAVE E LIMPO COM ÁGUA LIGEIRAMENTE ENSABOADA.

NUNCA FORCE AS UNIÕES. APORTE OS PARAFUSOS DEPOIS DE DETERMINADO TEMPO DE UTILIZAÇÃO.. CONSERVE O SEU MANUAL DE MONTAGEM, SE FALTAR UMA PEÇA SERIA A MANEIRA MAIS FÁCIL DE A COMUNICAR À LOJA.

NUNCA USE PRODUTOS ABRASIVOS TAIS COMO : LÃ DE AÇO, LIXAS, DISSOLVENTS, ETC.. NÃO MOLAR NEM SUBMETTER A GRANDES HUMIDADES, O MÓVEL.

ITALIANO

CONSIGLI PER IL MONTAGGIO:

- 1- STUDIARE ATTENTAMENTE IL MANUALE DI MONTAGGIO.
- 2- INDIVIDUARE LE PARTI CHE COSTITUISCONO IL MOBILE.
- 3- RACCOGLIERE E CONTROLLARE GLI ATTREZZI IN DOTAZIONE.
- 4- PROCURARSI GLI ATTREZZI NECESSARI.
- 5- PREPARARE UNA ZONA PER IL MONTAGGIO.

CONSIGLI PER LA MANUTENZIONE:

- 1- SPOLVERARE ACCURATAMENTE.
- 2- INUMIDIRE UN PANNINO MORBIDO E PULITO CON ACQUA E POCO DETERGENTE.

NON FORZARE MAI LE GIUNTURE. STRINGERE NUOVAMENTE LE VITI DOPO UN CERTO PERIODO D'USO. CONSERVARE IL MANUALE DI MONTAGGIO: SE MANCASSE UN PEZZO SAREBBE COSÌ PIÙ FACILE COMUNICARLO AL RIVENDITORE.

NON USARE MAI PRODOTTI ABRASIVI COME: SPUGNE ABRASIVE, CARTA VETRATA, SOLVENTI, ECC. NON BAGNARE NE' SOTTOPORRE IL MOBILE A FORTE UMIDITÀ.

اللغة العربية

تعليمات التجميع:

- 1-اقرأ تعليمات التجميع بعناية.
- 2-حدد موقع الأجزاء التي يتكون منها أثاثك.
- 3-الجمع والتحقق من الأجهزة المقدمة.
- 4-هل لديك الأدوات اللازمة.
- 5-جهز مساحة التركيب.

إرشادات الصيانة:

- 1-قم بإزالة الغبار بعناية.
- 2-قم بتطهير قطعة قماش ناعمة ونظيفة بالصابون الخفيف والماء.

لا تفرض التركيبات أبداً. شد البراغي بعد وقت معين من الاستخدام. احفظ تعليمات التجميع. في حالة وجود جزء مفقود ، ستكون هذه أفضل طريقة لإعلام المتجر.

لا تستخدم أبداً المنتجات الكاشطة مثل الصوف الصلب ، ورق الرمل ، والمذيبات ، وما إلى ذلك. لا تبلل الأثاث وتجنب أي تعرض للرطوبة العالية.

HERRAJES

FERRURES

MÖBELBESCHLÄGE

ACCESSORI
PER MOBILI

FERRAGENS

OKUCIA
MEBLOWE

FURNITURE
FITTINGS

T1



x8

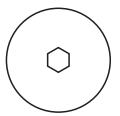
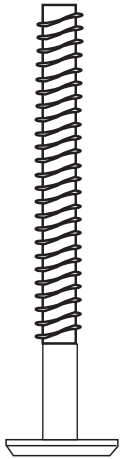

TM660A

x8



TUEM61013

x18



PE845

x18



EX16

T2



x12

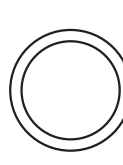
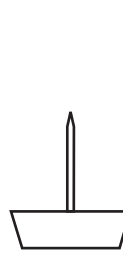

TSM

x26



CL830

x4

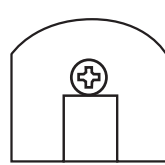
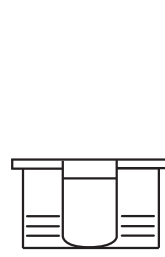

SKM16

x4



TCK0311

T3



x6



CL1060

x28

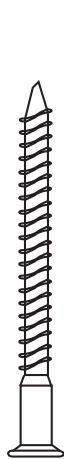

TA550

x1

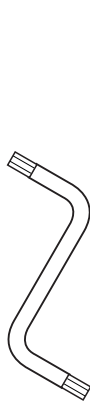

LLA3

x4



TP3540

T4



x2

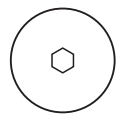
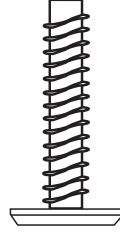

TM630A

x2

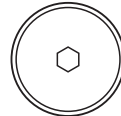
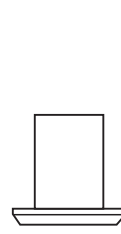

CM670

x4



TV3135

x44



TP3515

T5



x2

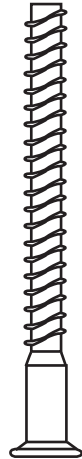

TA760

x1

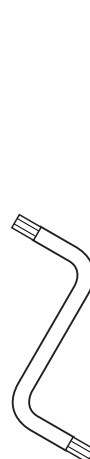

LLA4

x2



TP3530

x4



TP4016

Y



x2

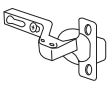

B35SA

x2



BA35S

HERRAJES

FERRURES

MÖBELBESCHLÄGE

ACCESSORI
PER MOBILI

FERRAGENS

OKUCIA
MEBLOWE

FURNITURE
FITTINGS

T6

x10

x2

x6

x8



TA3RK

TA4RK

T10RK

TE17RK

T7

x22

x2

x10



TA3BL

T8BL

TE17BL

X

x8

x1

x1

x1

x2

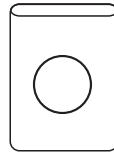
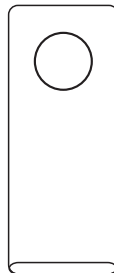
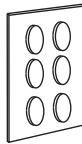
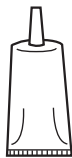

RTC24

P1030

COLA

CT715

E2137

AC

x4

x3

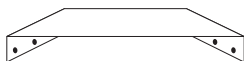

ESJ

AAM220

TCA4030

1/4

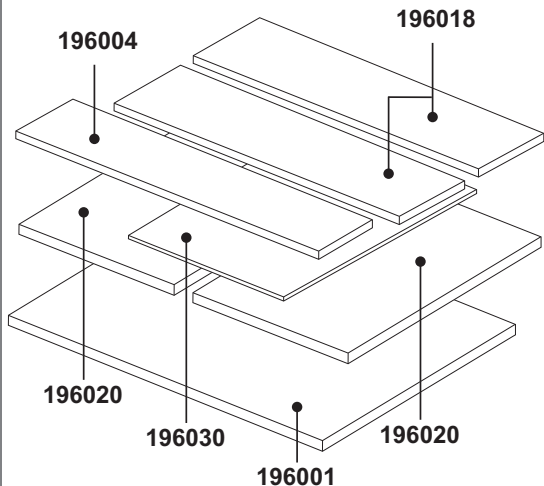

1960A

2/4



T1 T2
 T3 T4
 T5 T6
 T7 X
 Y AC

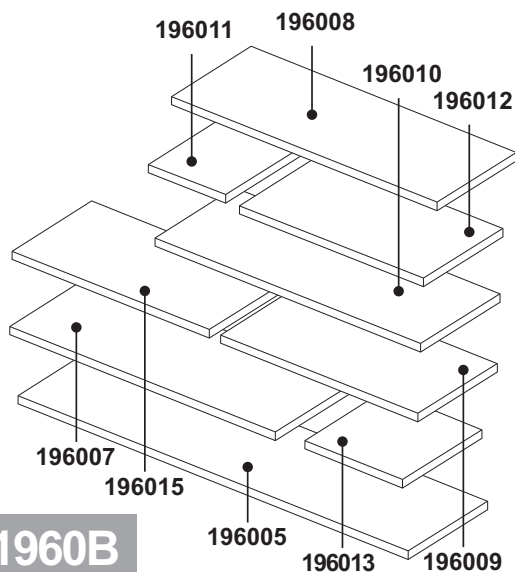

1960B

3/4

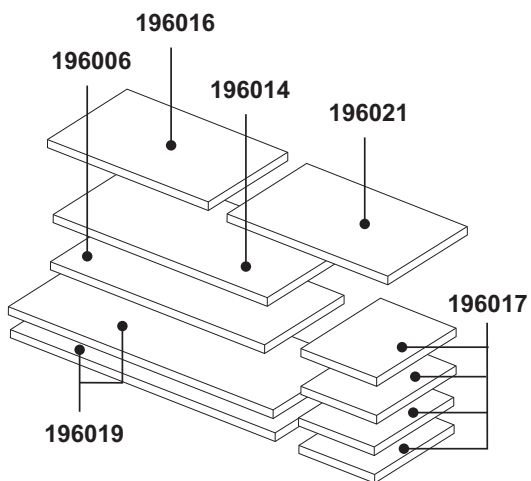

1960C

4/4

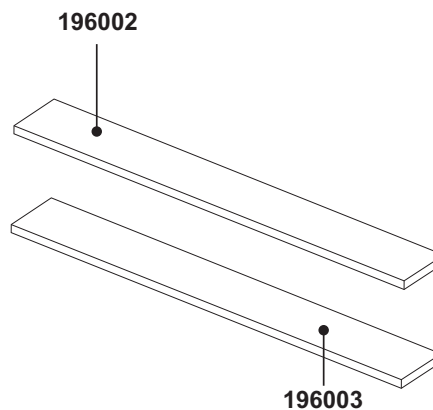

1960D

1

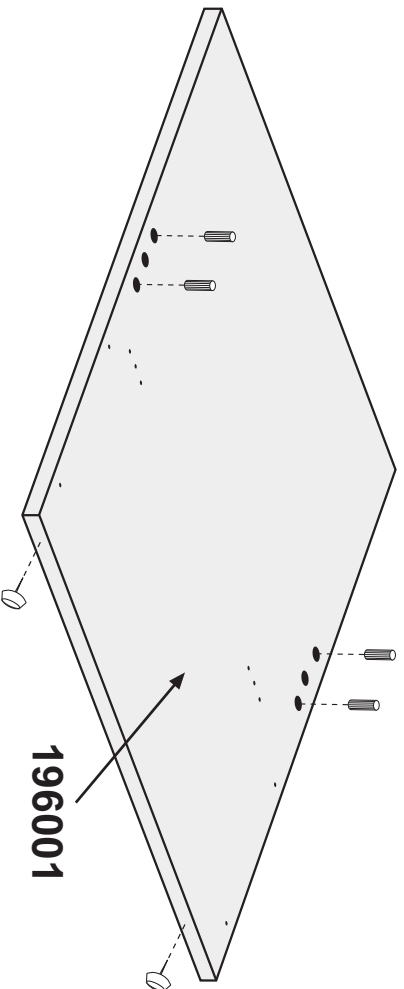

196004

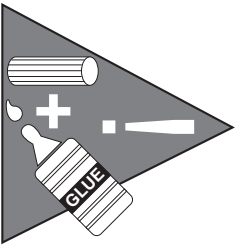
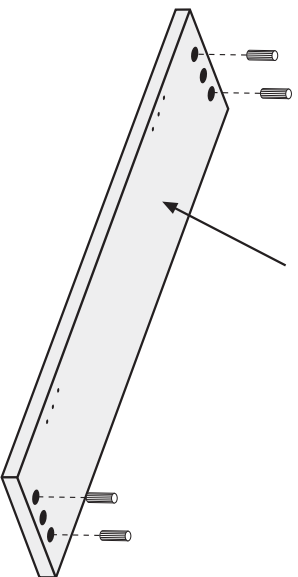

cm 0 1 2 3

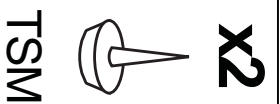

2

TP3515 X4

cm 0 1 2

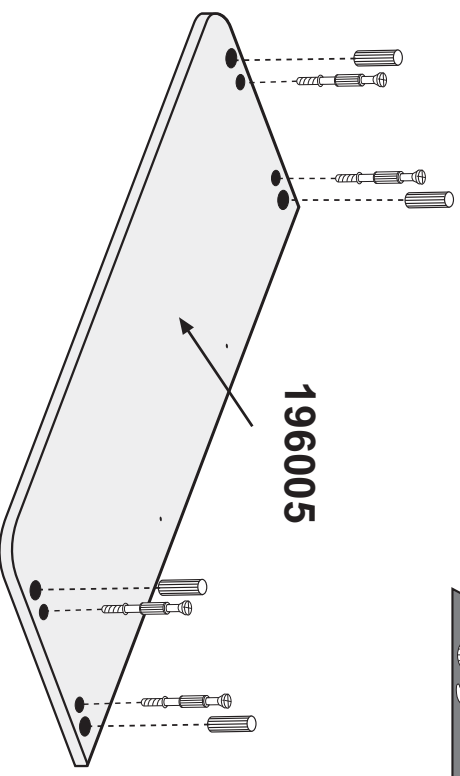
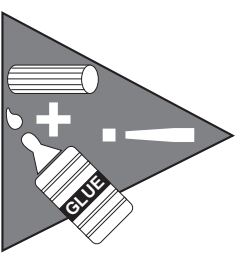

196005

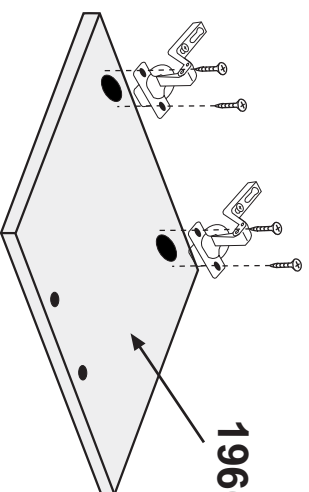

196021

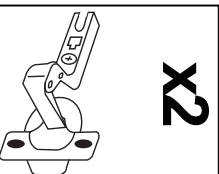

cm 0 1 2 3 4 5

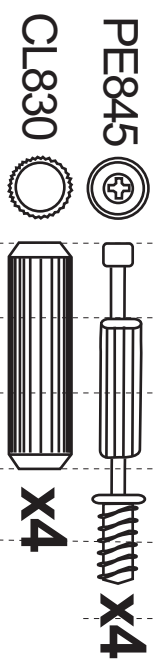

3

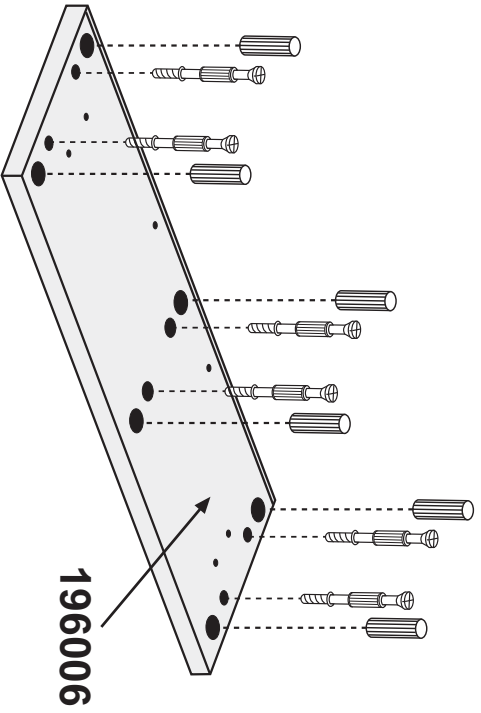
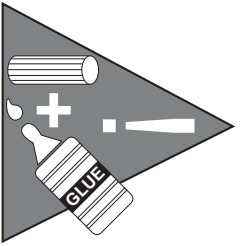

196006

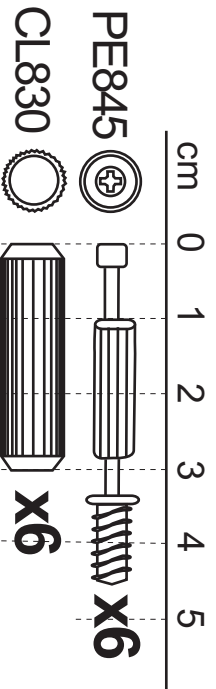

4

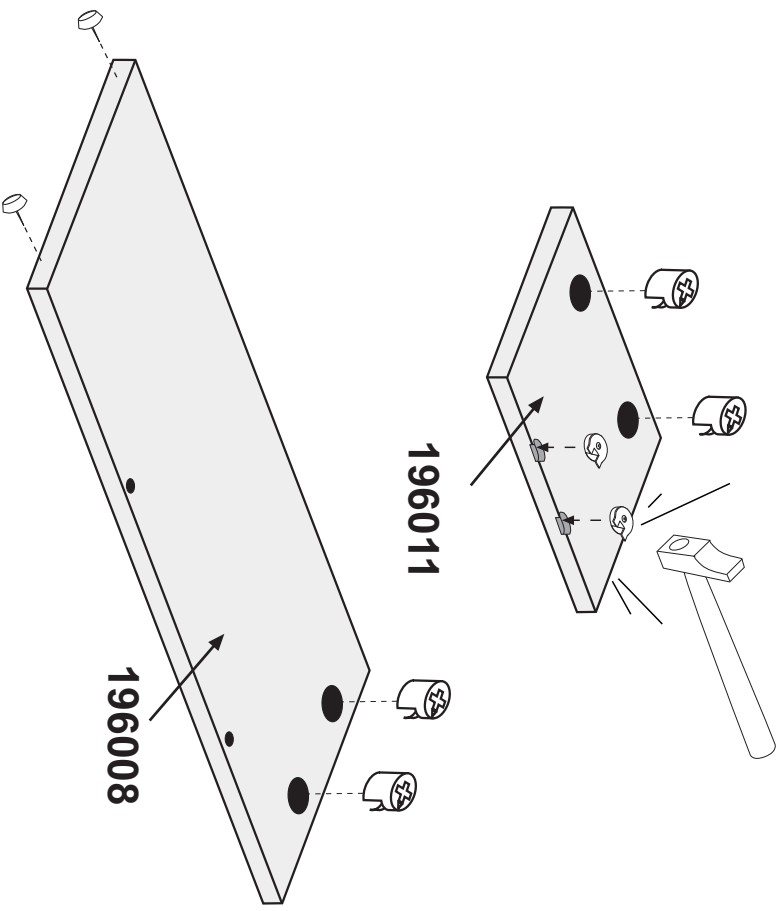

196011

196008

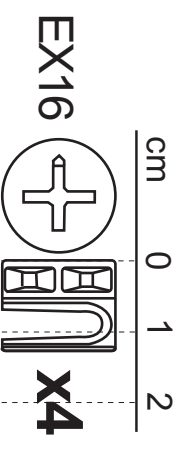
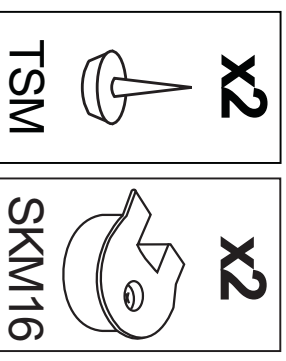

5

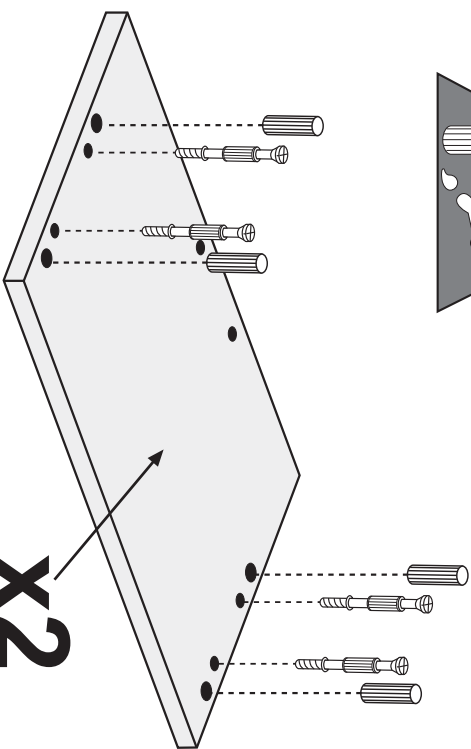
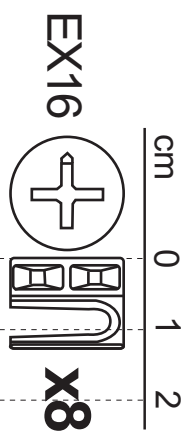
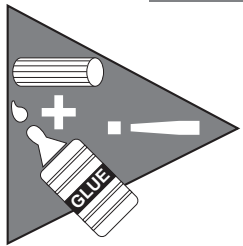

X2
196020

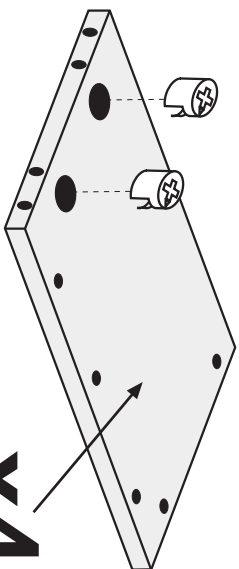

X4
196017

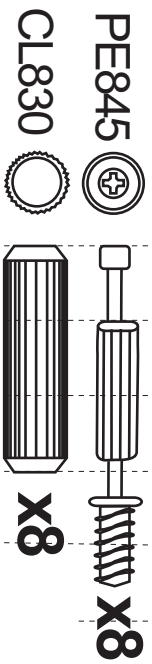

6

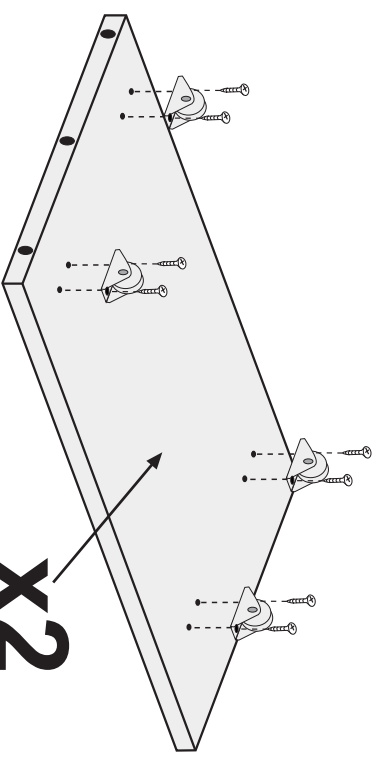
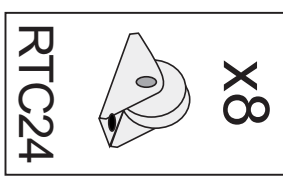

X2
196019



7

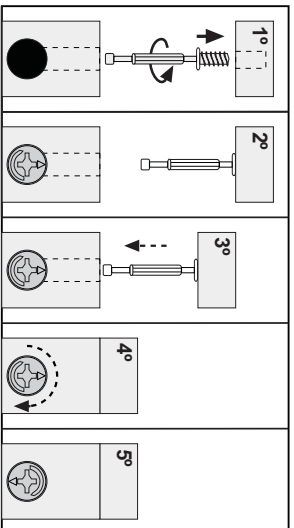
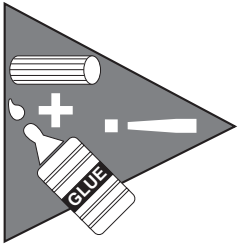

X2

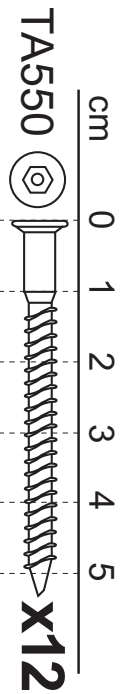
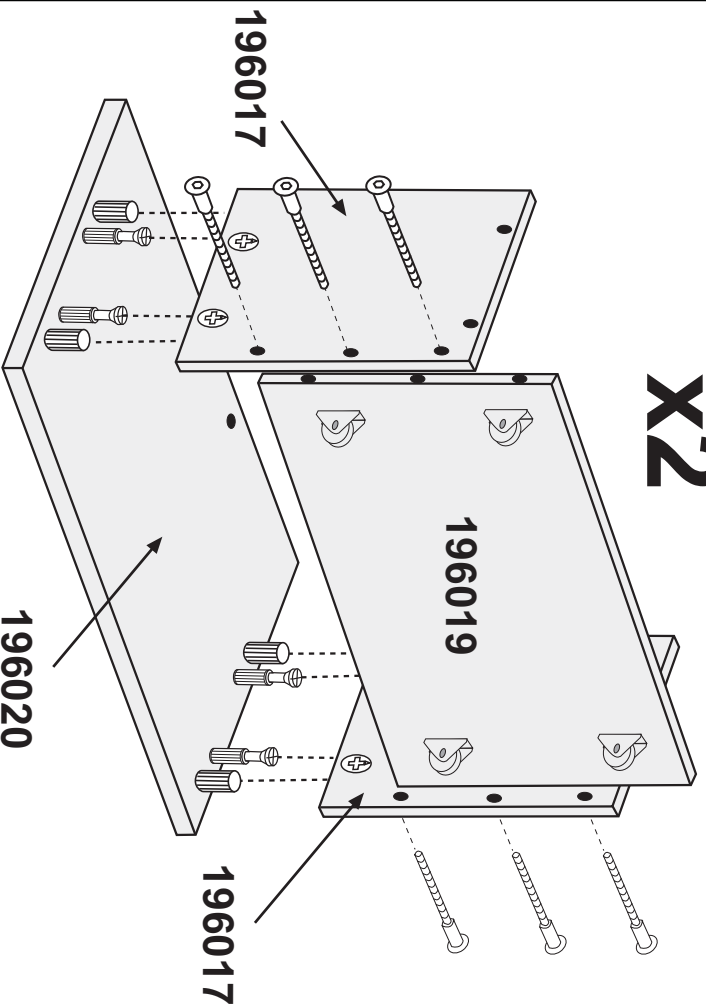

8

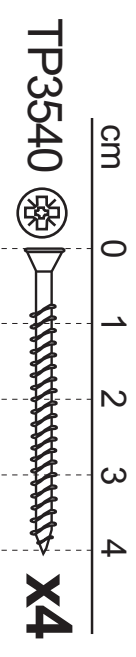

X2

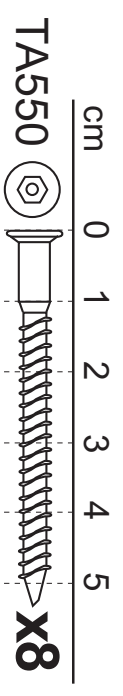
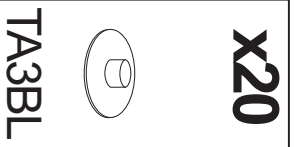
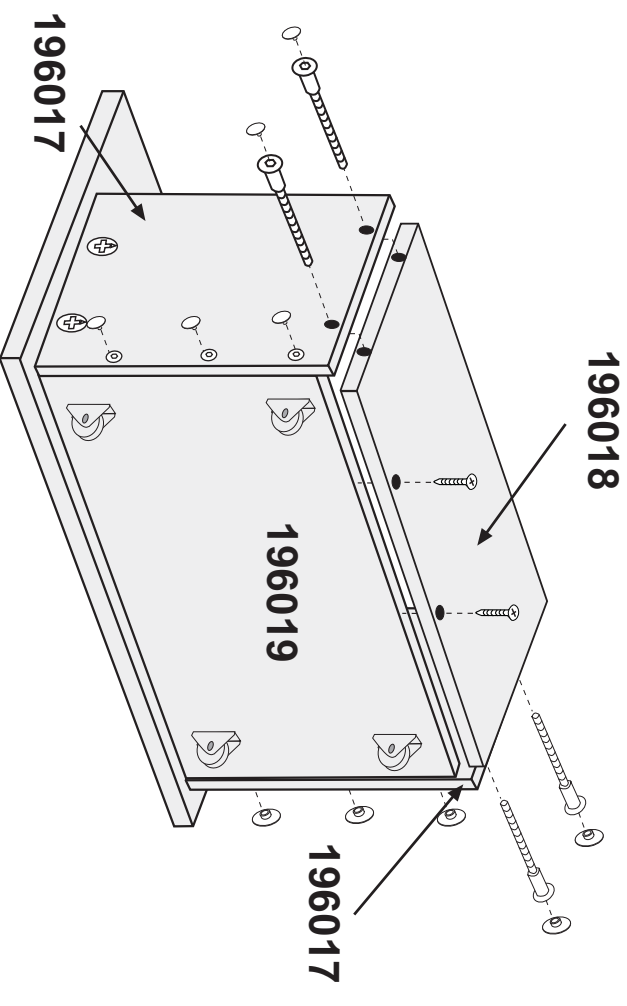

9

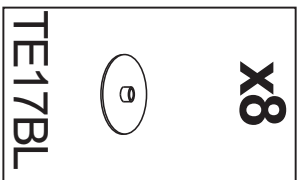
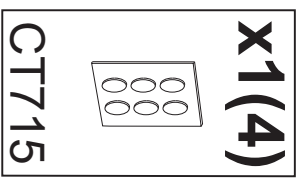
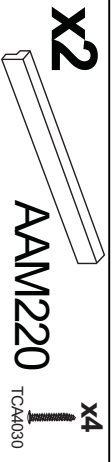
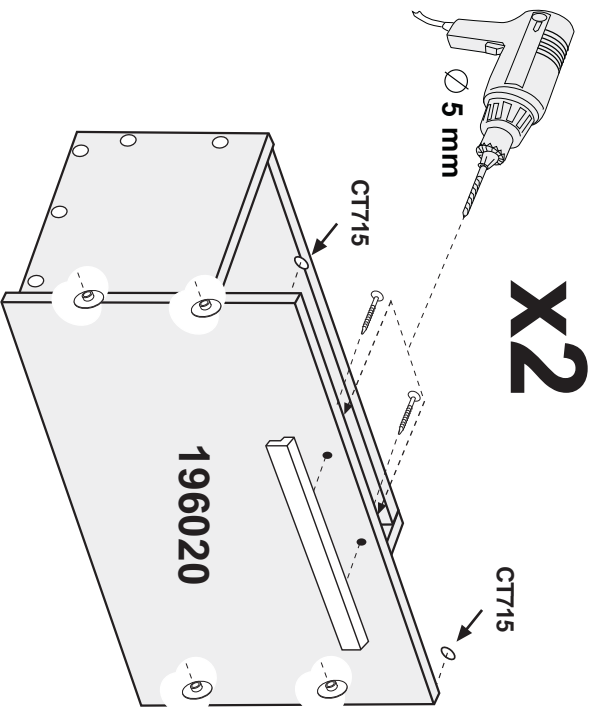

10

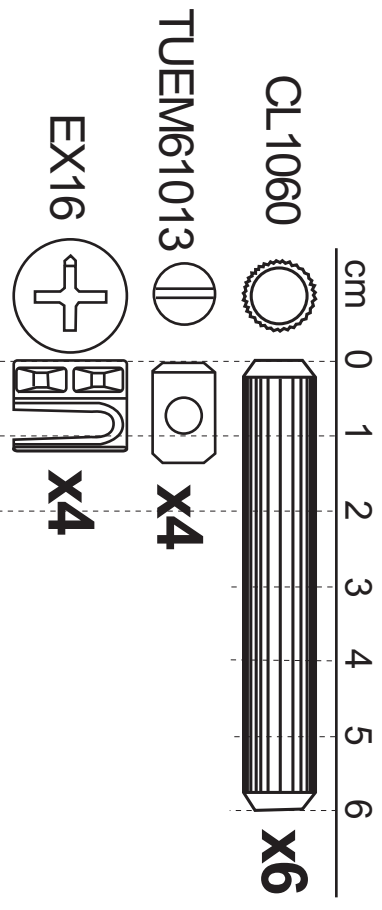
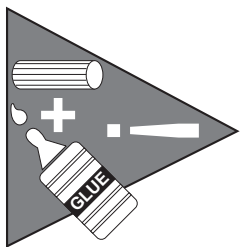
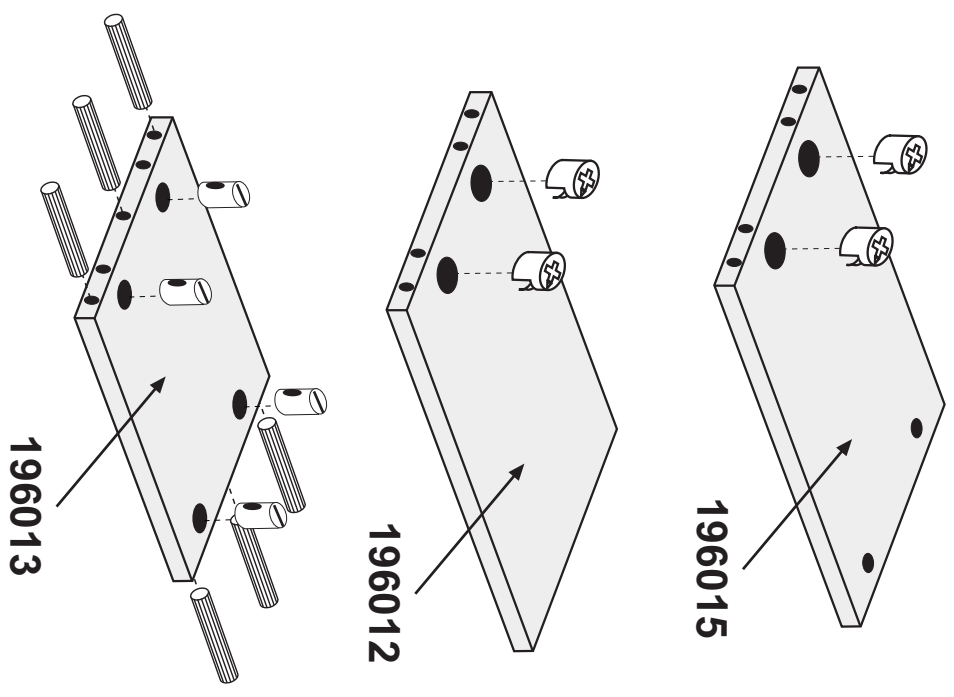

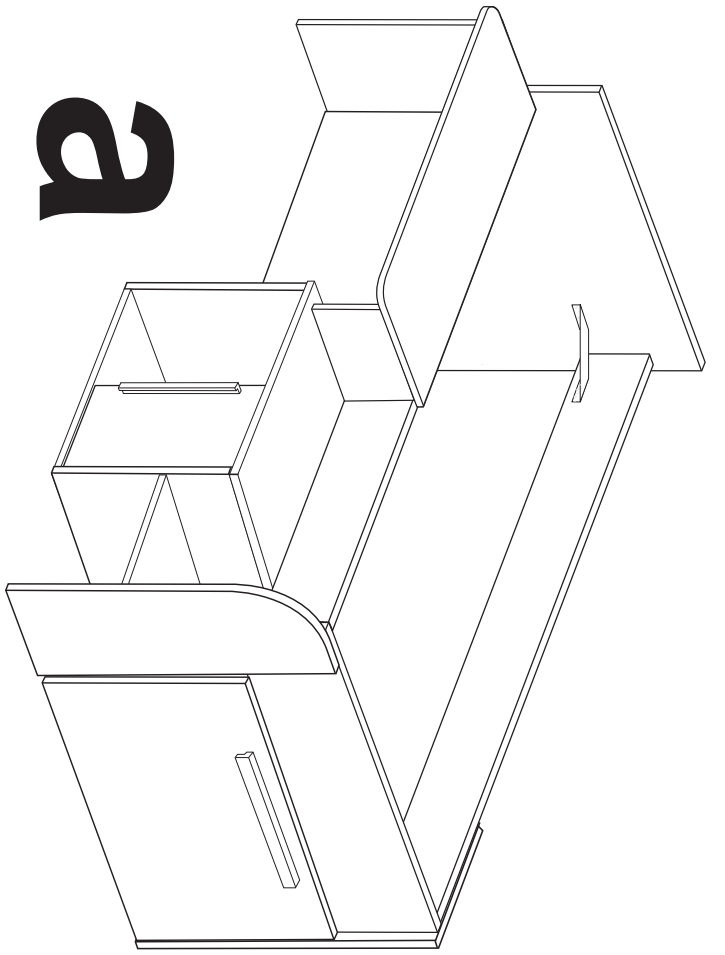

a

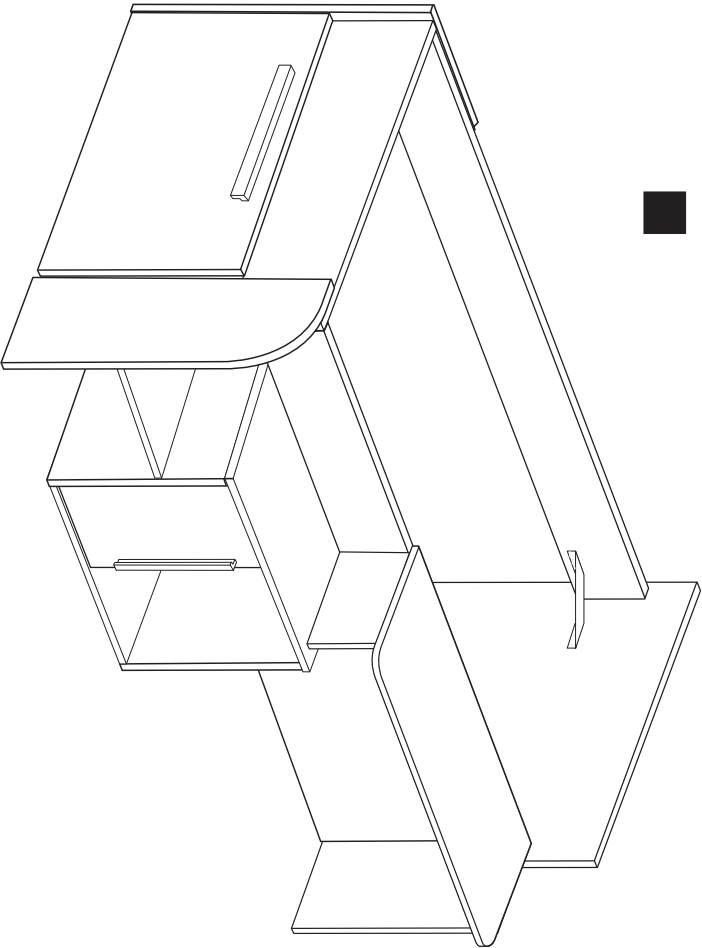

b

a

cm 0 1 2 3 4 5 6

TA550  X4

TV3135  X4

EX16  X2

11a

X2



BA35S

X4



TA3RK

196009

196014

196015

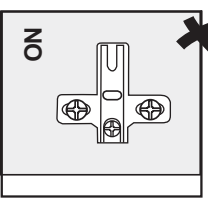
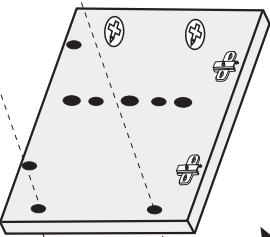
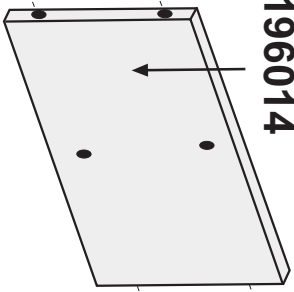
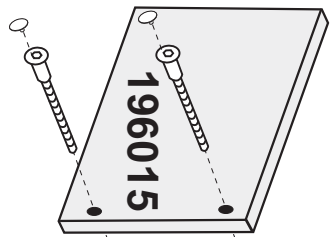

NO

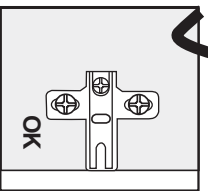

OK

12a

196012

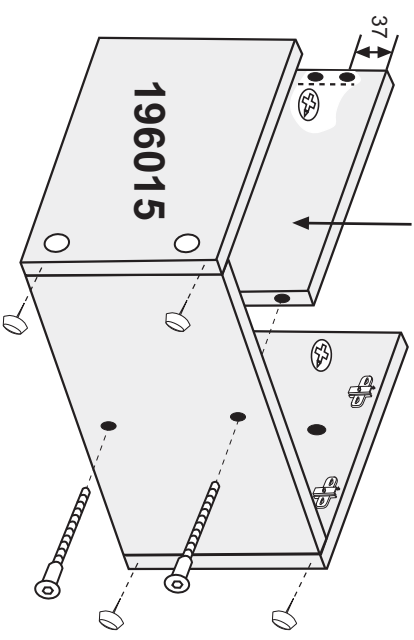

196006

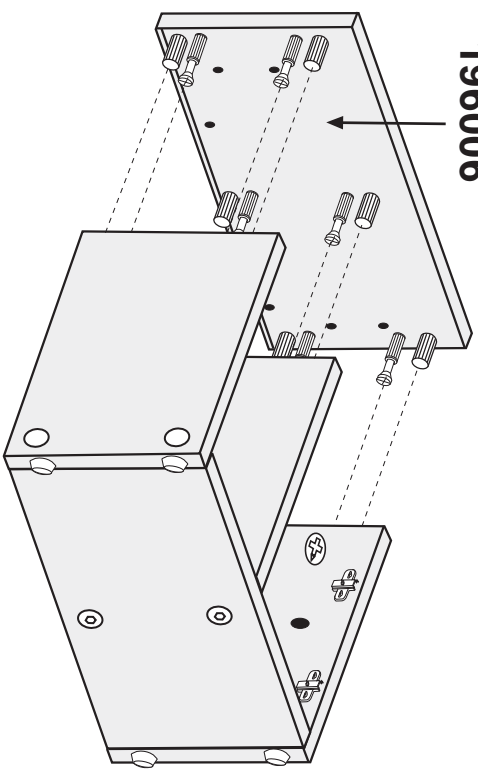

cm 0 1 2 3 4 5

TA550  X2

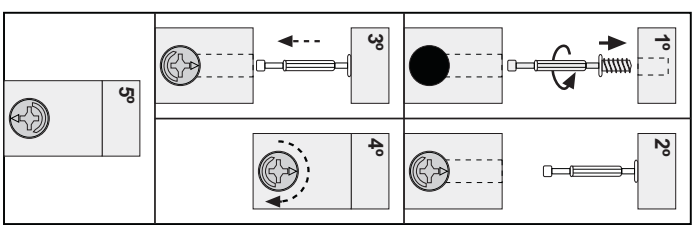

X4



TSM

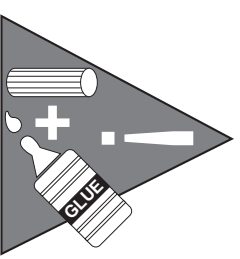

13a

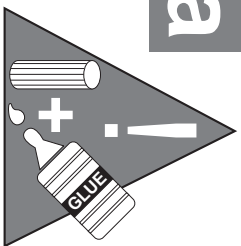

x2		TA3RK
x3		T10RK

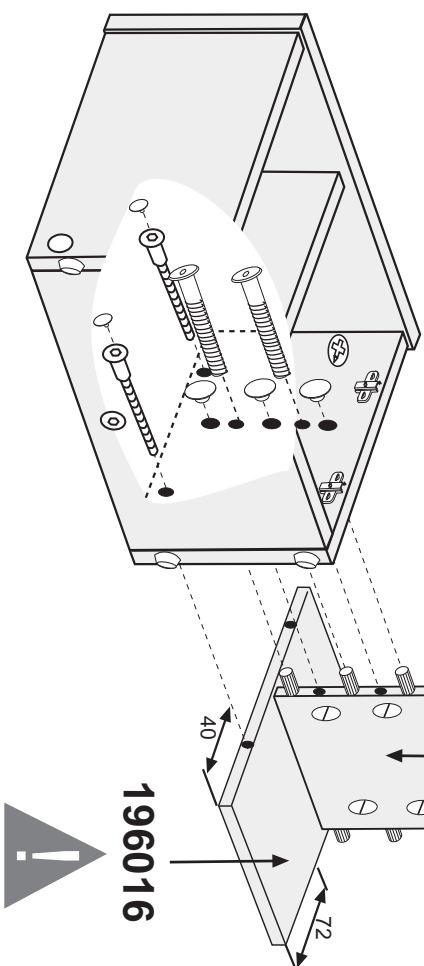

cm 0 1 2 3 4 5 6

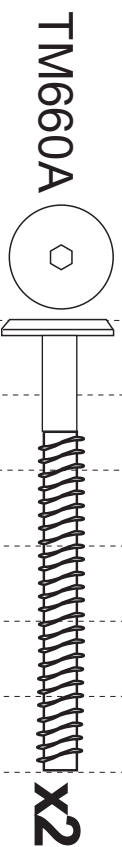

14a

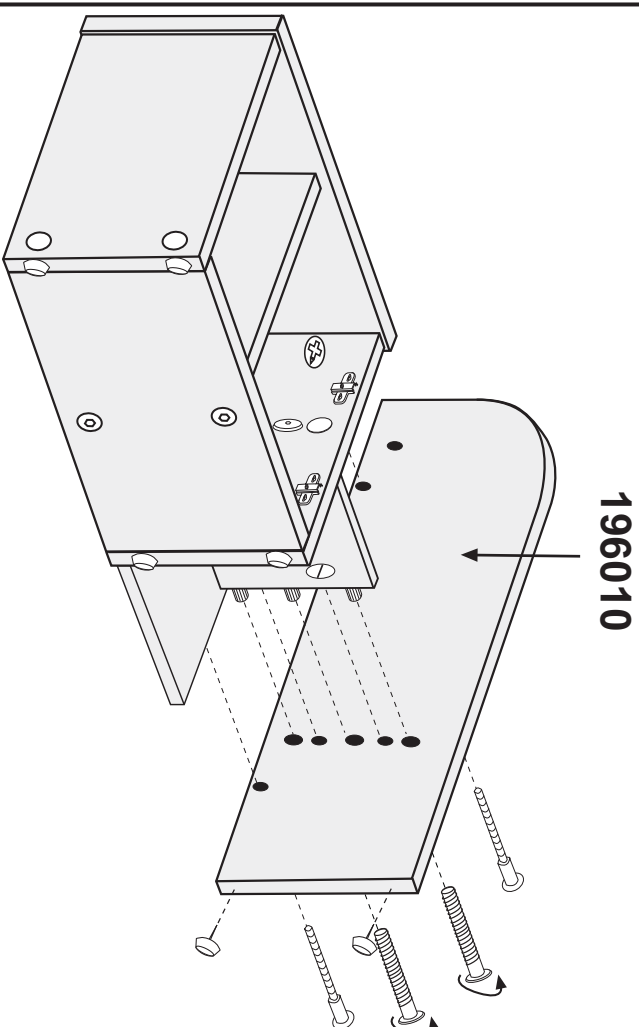
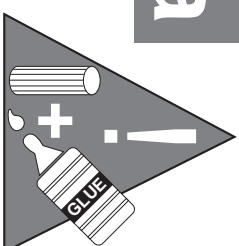

cm 0 1 2 3 4 5 6

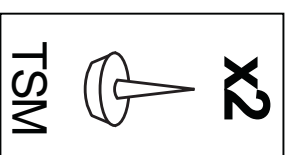
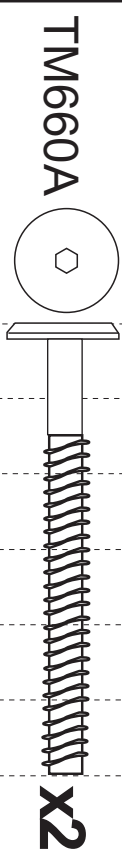
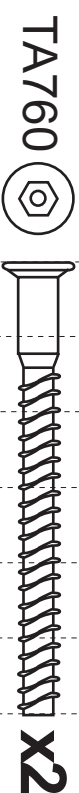

15a

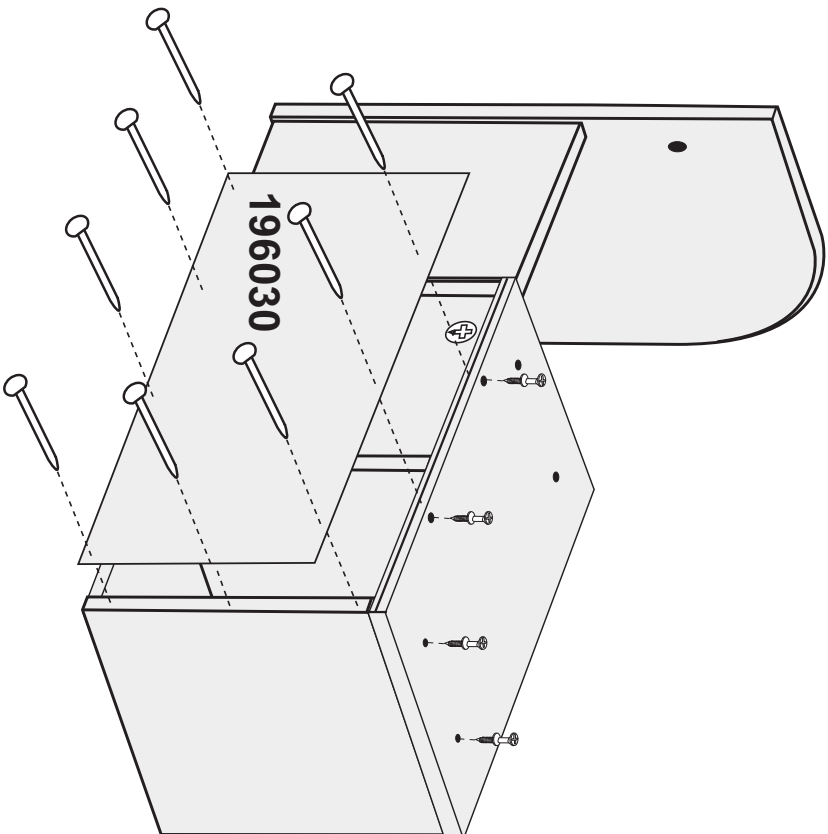



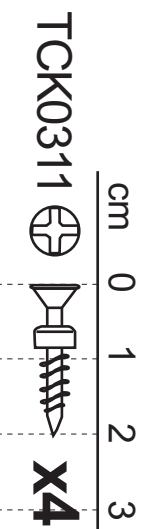

X30

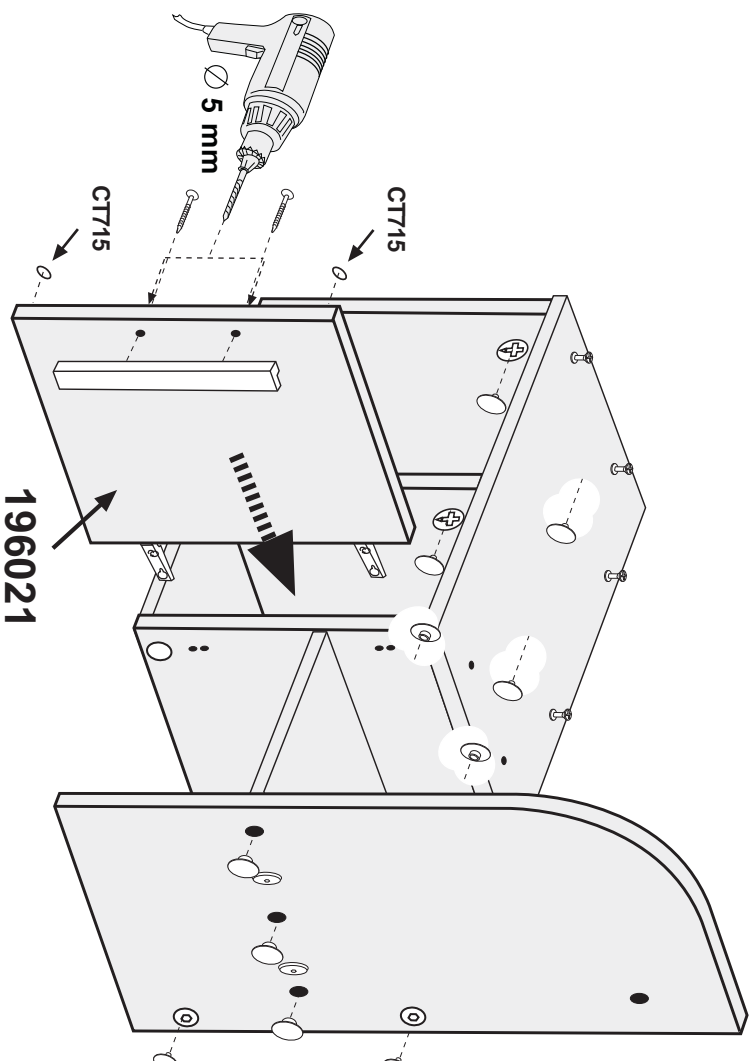
 P1030

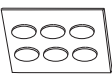

16a



X1(2)

 CT715

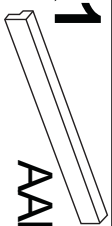
- X3**

T10RK
- X2**

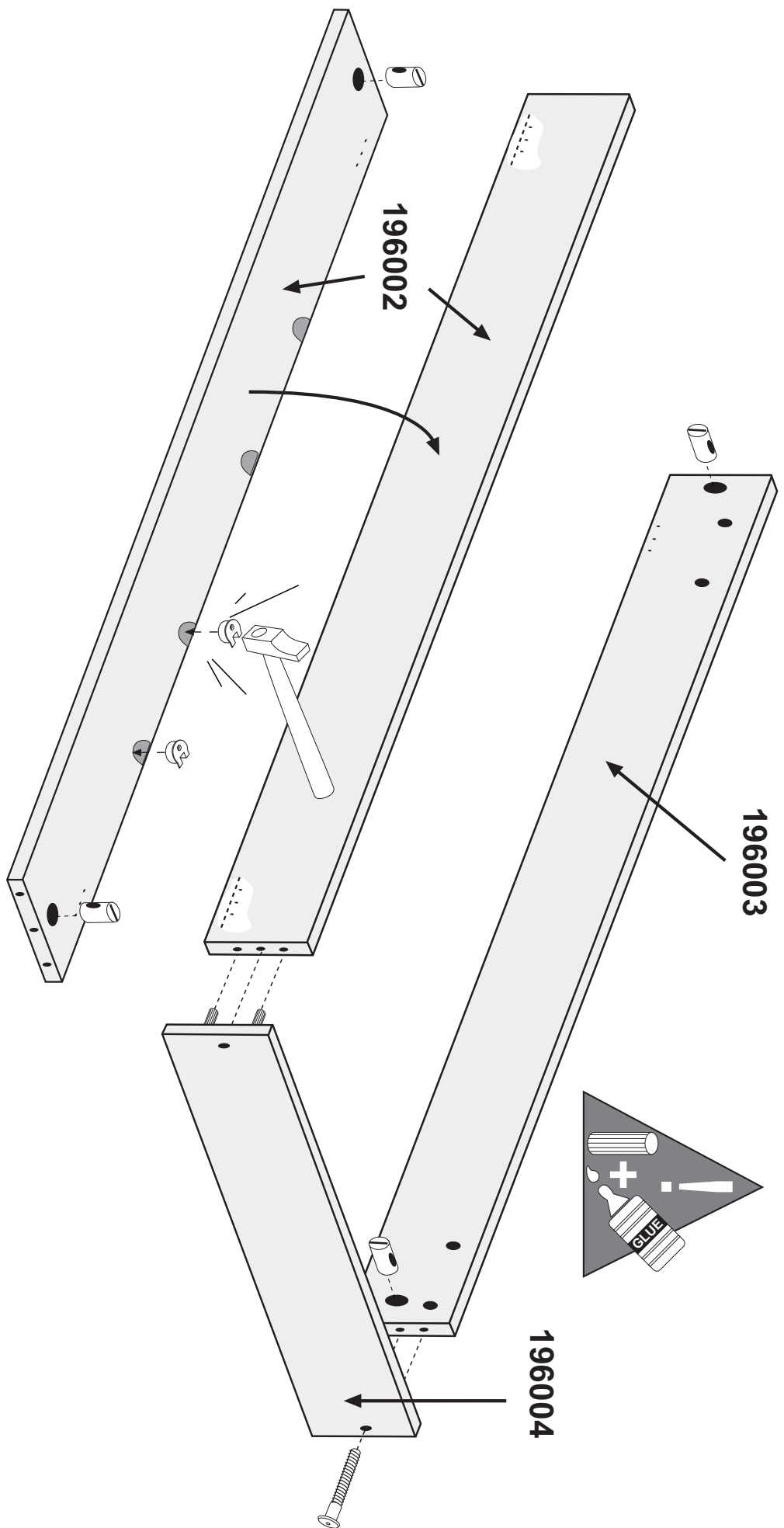
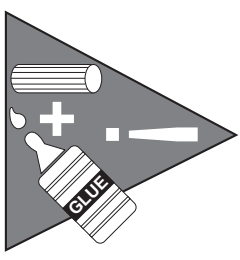
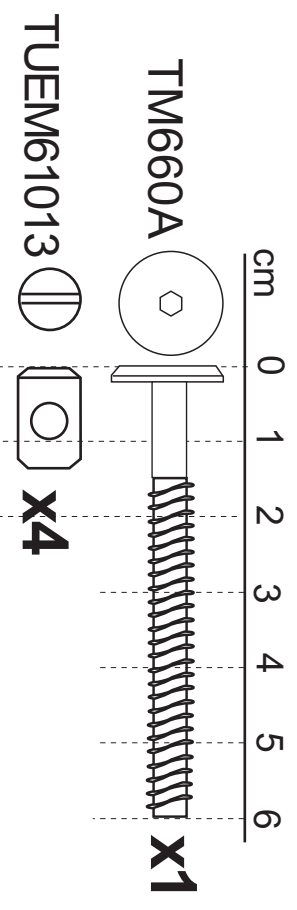
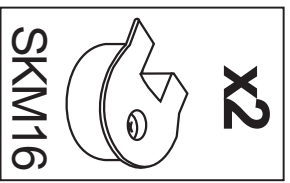
TA4RK
- X2**

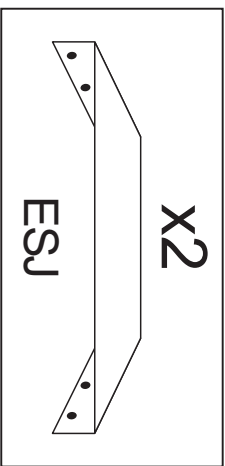
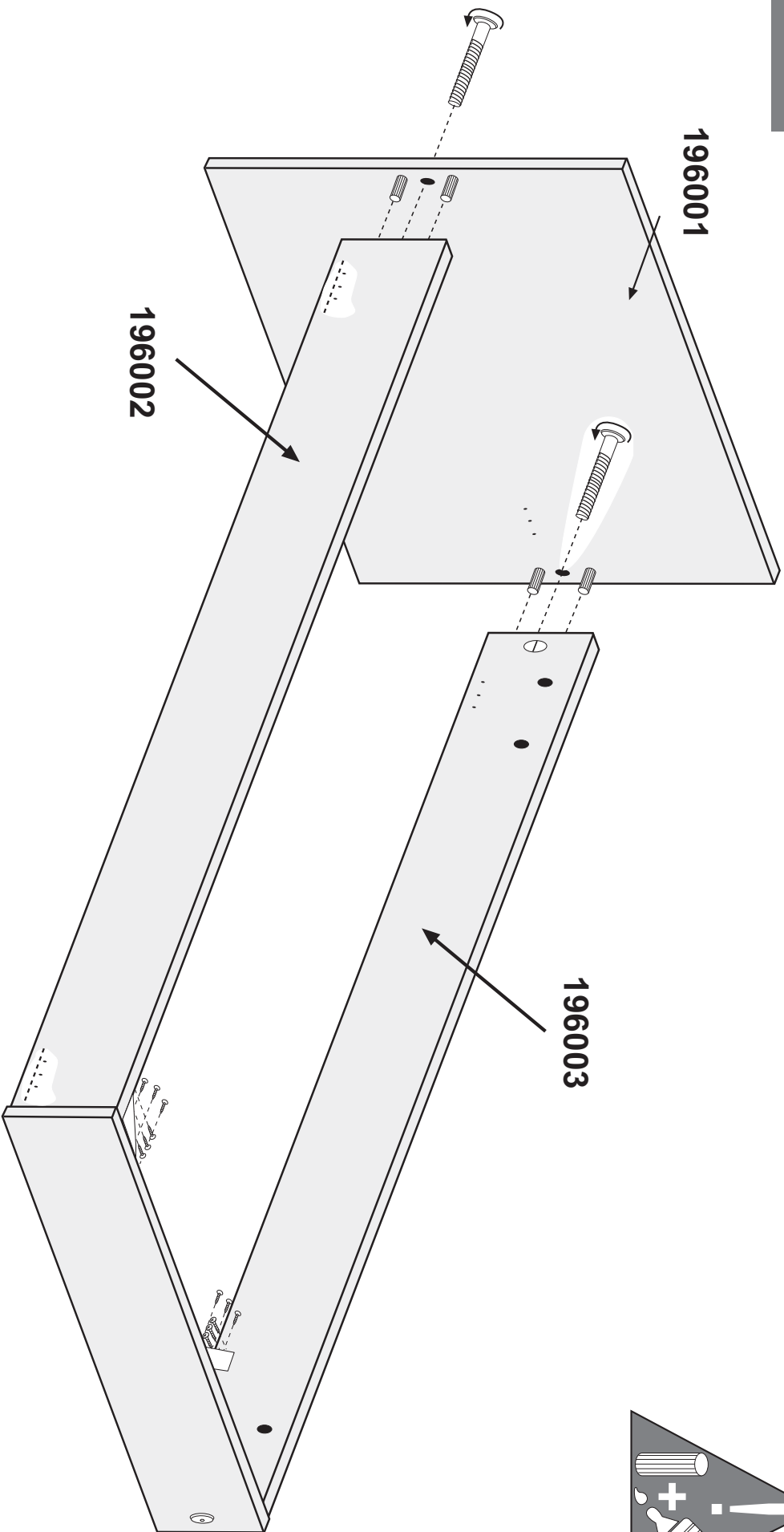
TE17BL
- X4**

TE17RK

X1

 AAM220
 TCM030
X2

17a



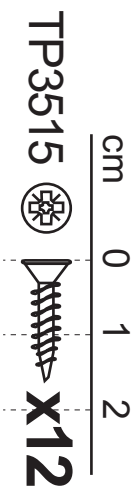

X2
ESJ



TP3515 X12

cm 0 1 2

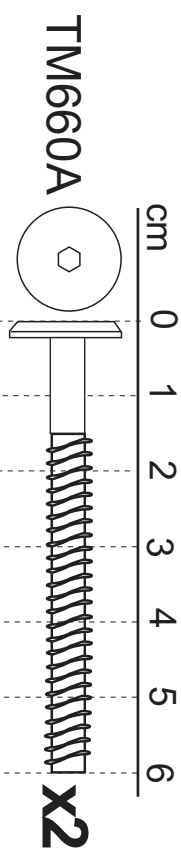

TM660A

cm 0 1 2 3 4 5 6

X2

19a

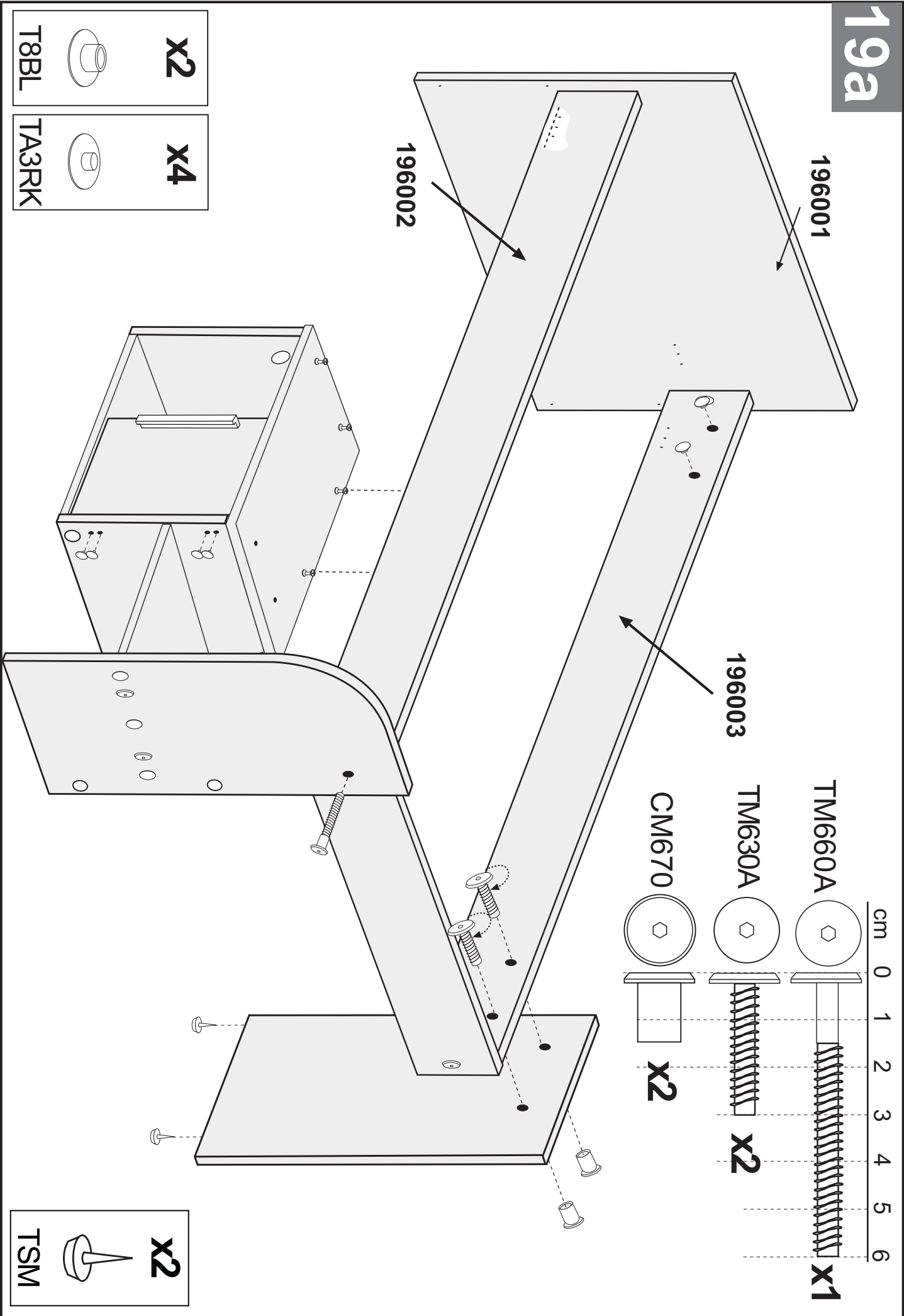

20a

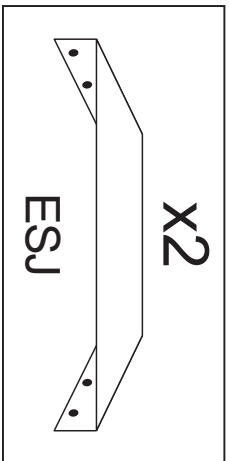
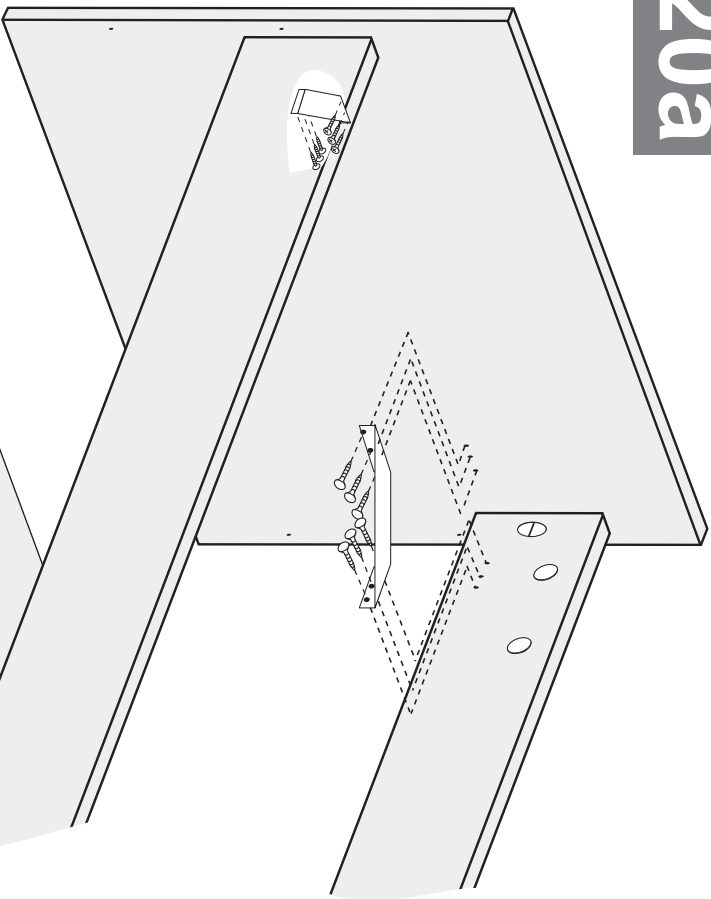

X2

ESJ

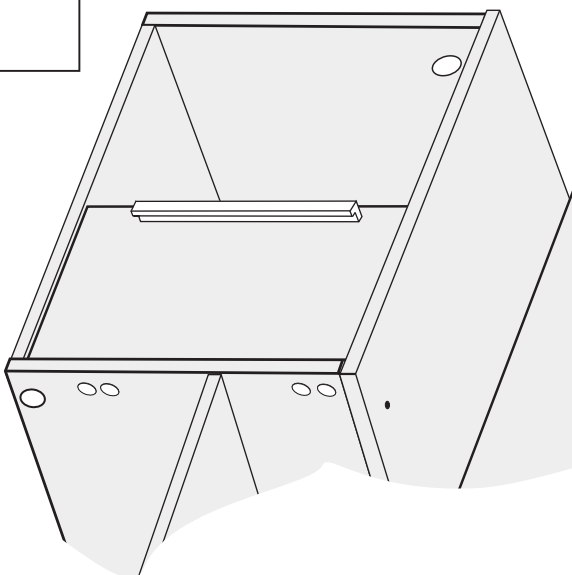

cm

0

1

2

TP3515



X12

21a

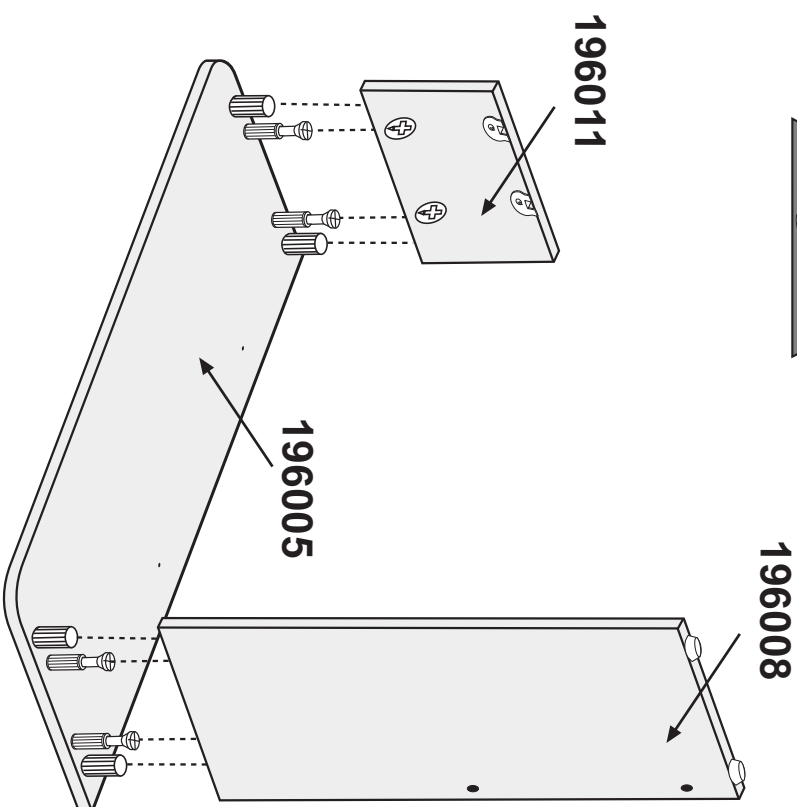
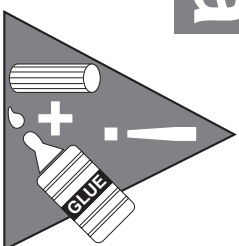



196011

196005

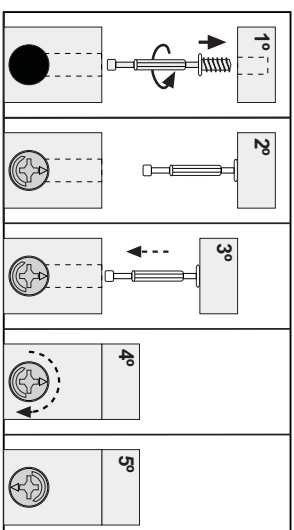
196008



22a

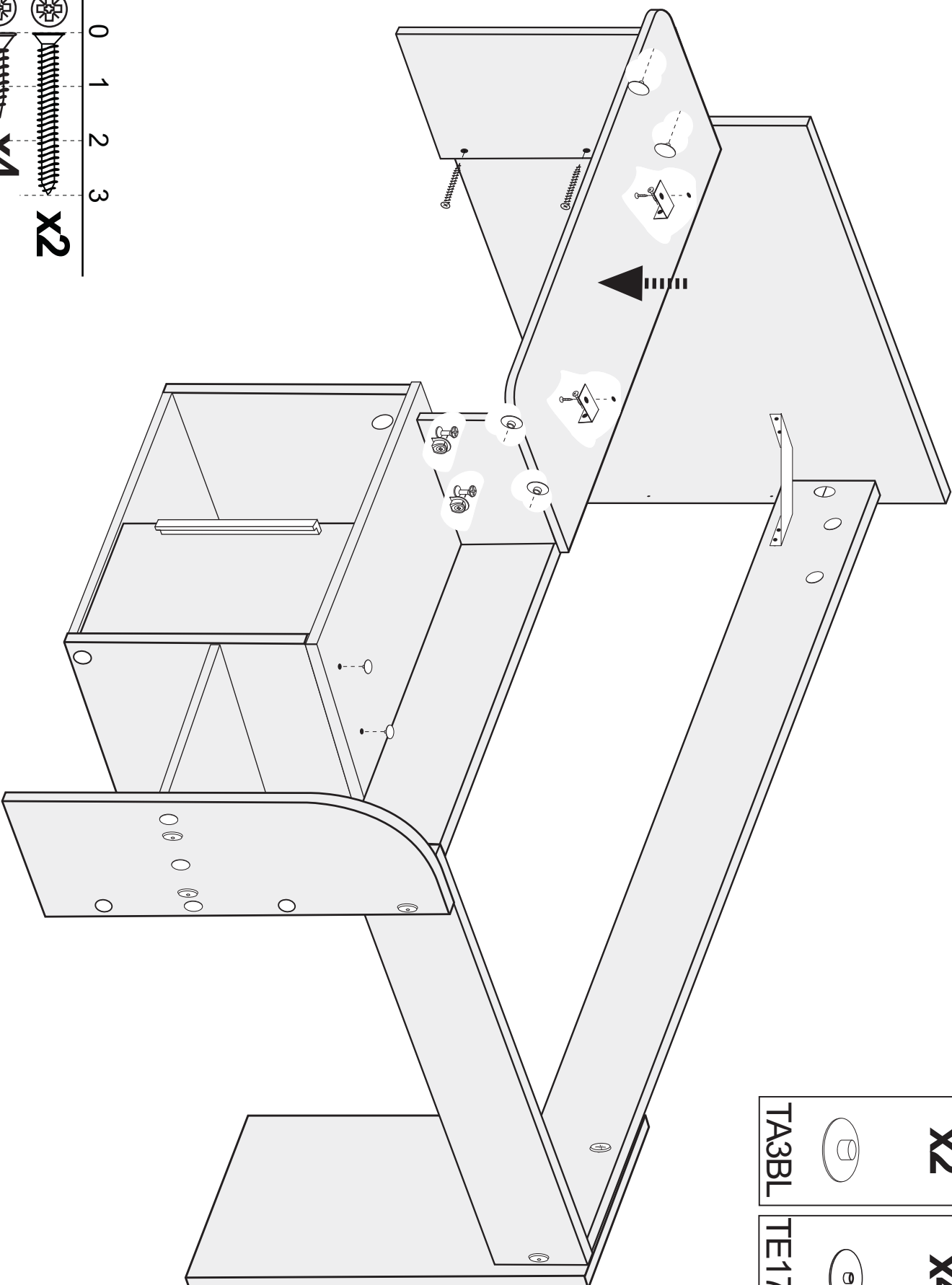

X2	
X4	



X2	
-----------	---

E2137

cm 0 1 2 3

X2	
X4	

TP3530

TP4016

X2

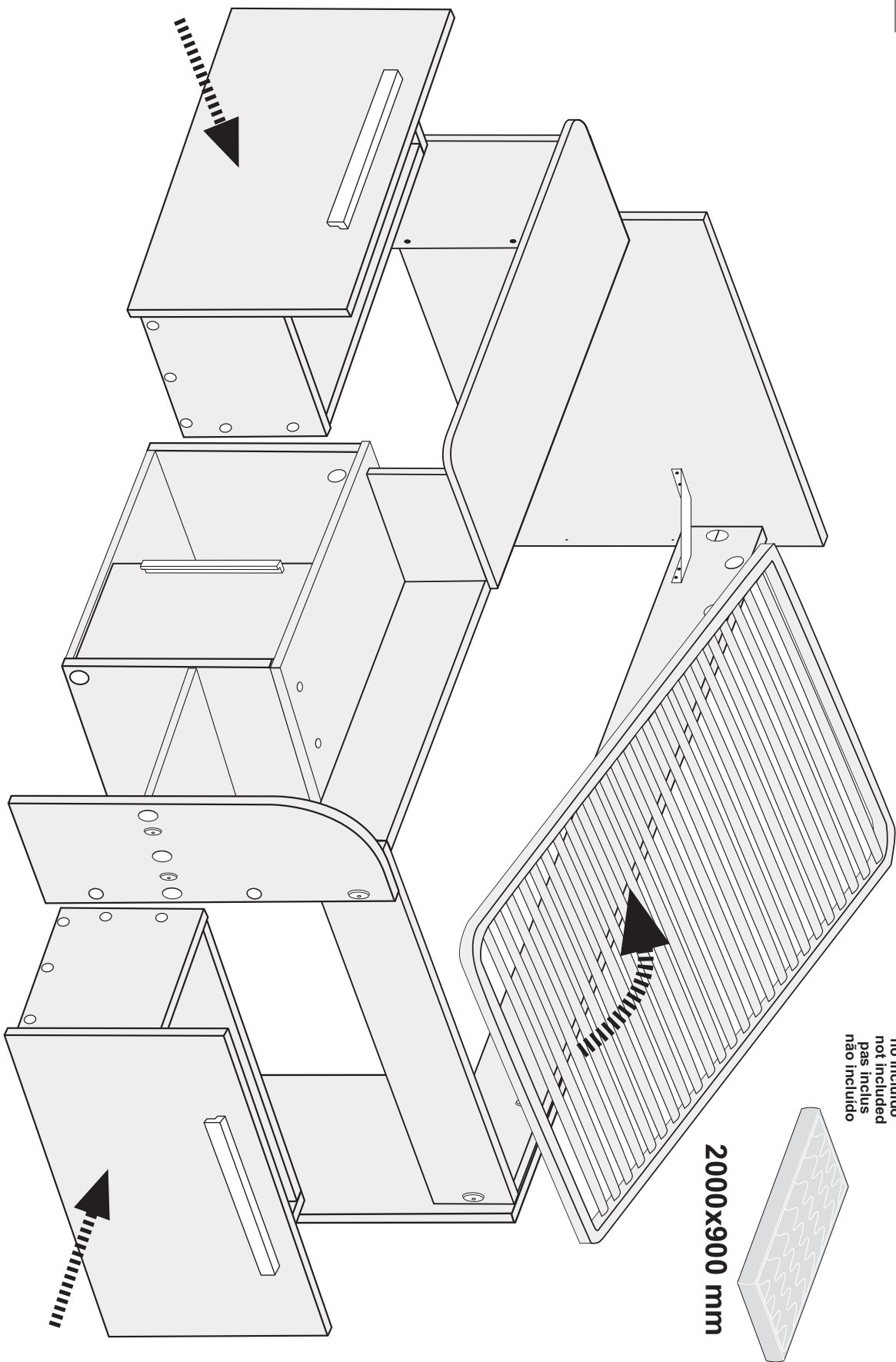

no incluido
not included
pas inclus
não incluido

2000x900 mm

cm 0 1 2 3 4 5 6

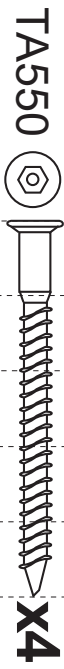

11b

X2



BA35S

X4

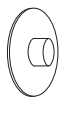

TA3RK

196009

196014

196015

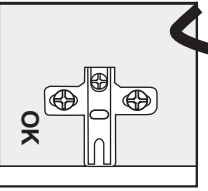
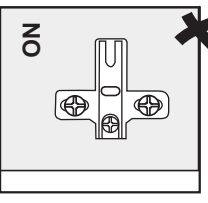
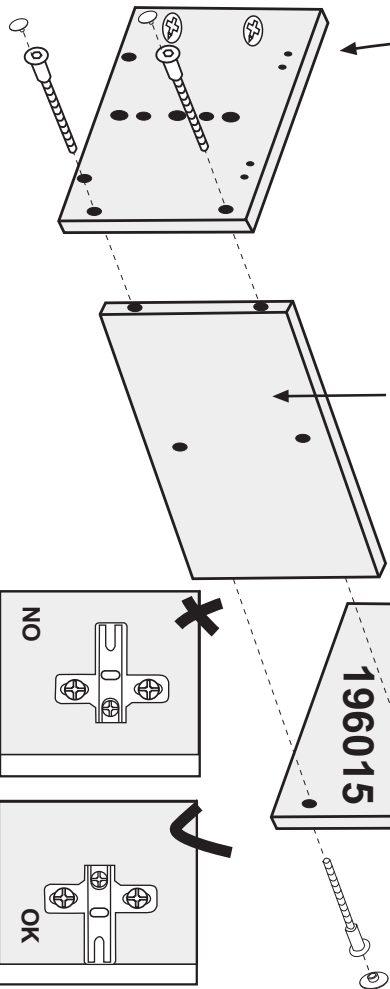

12b

196012

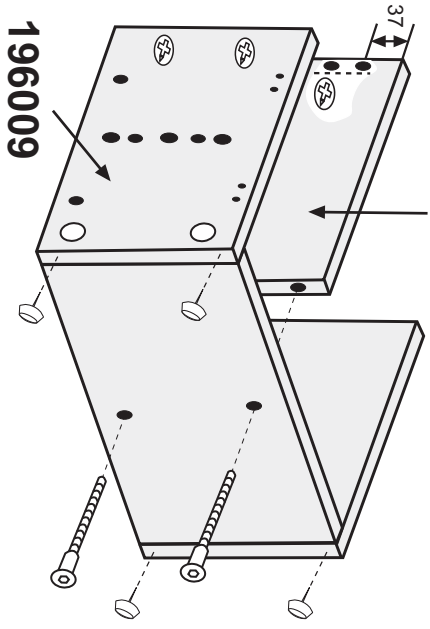

196009

196006

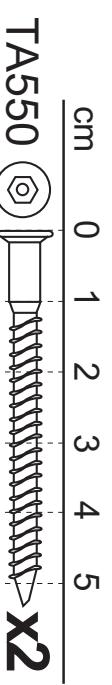

TA550

cm 0 1 2 3 4 5

X2

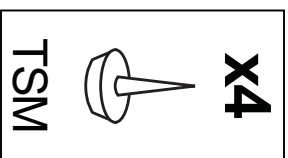
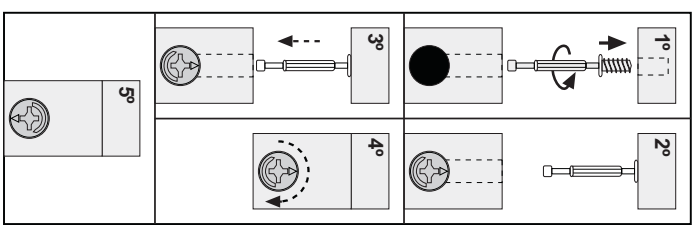

X4

TSM

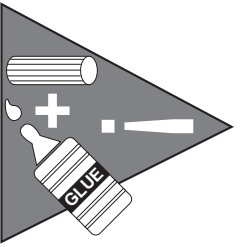

13b

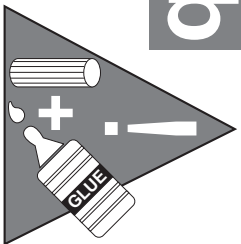

x2		TA3RK
x3		T10RK

196013

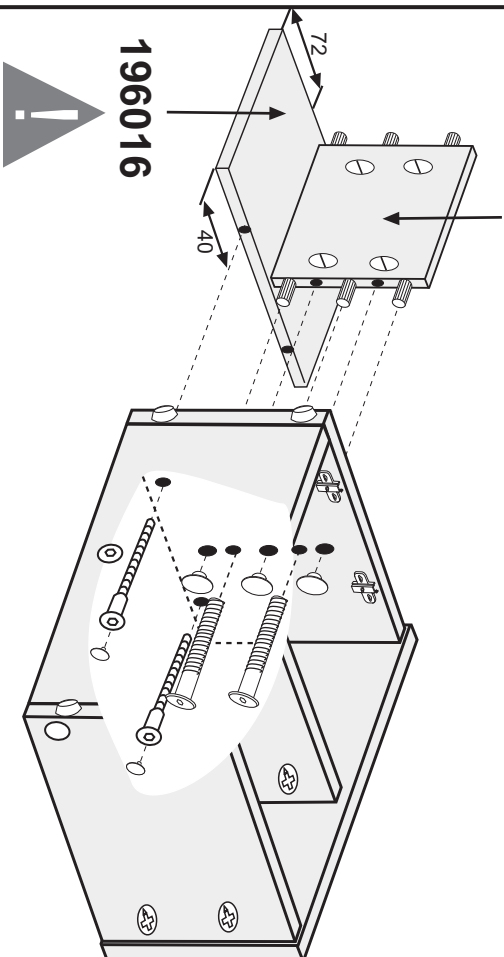

196016

cm 0 1 2 3 4 5 6



x2

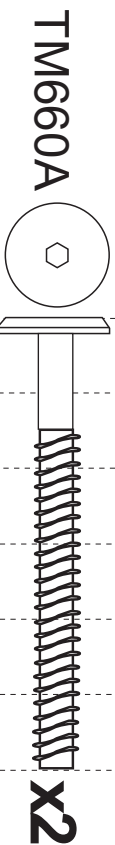

x2

14b

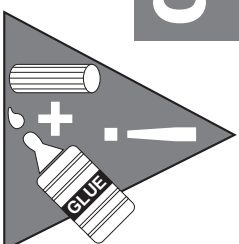

196010

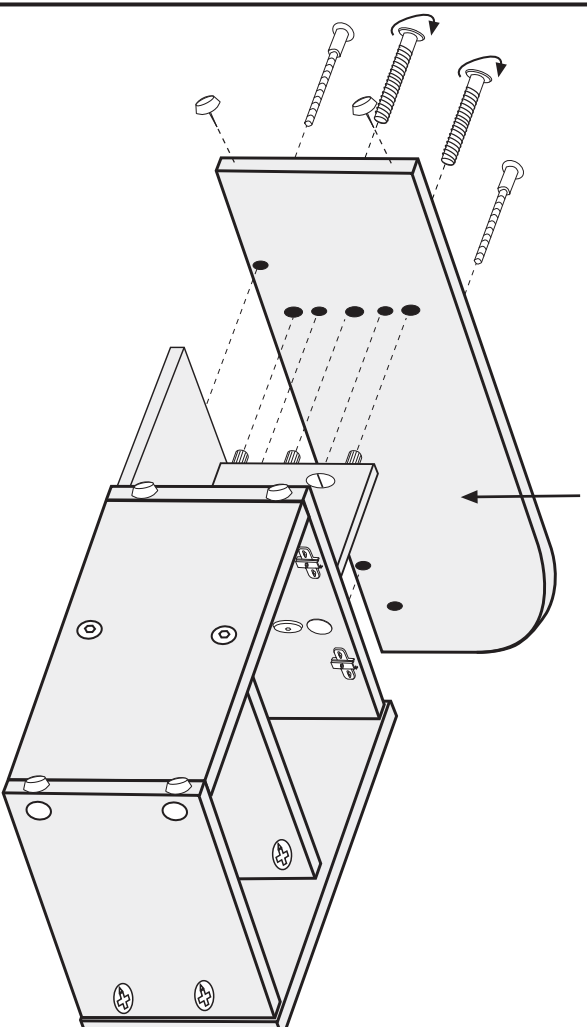

cm 0 1 2 3 4 5 6

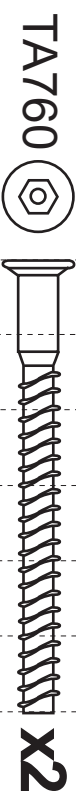

x2

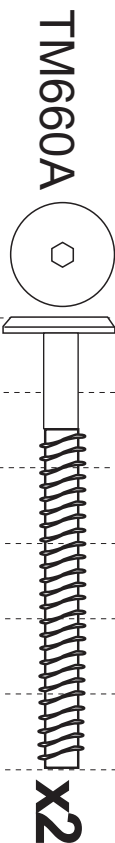

x2

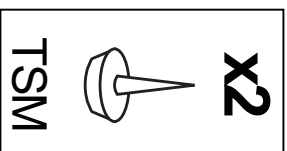

15b

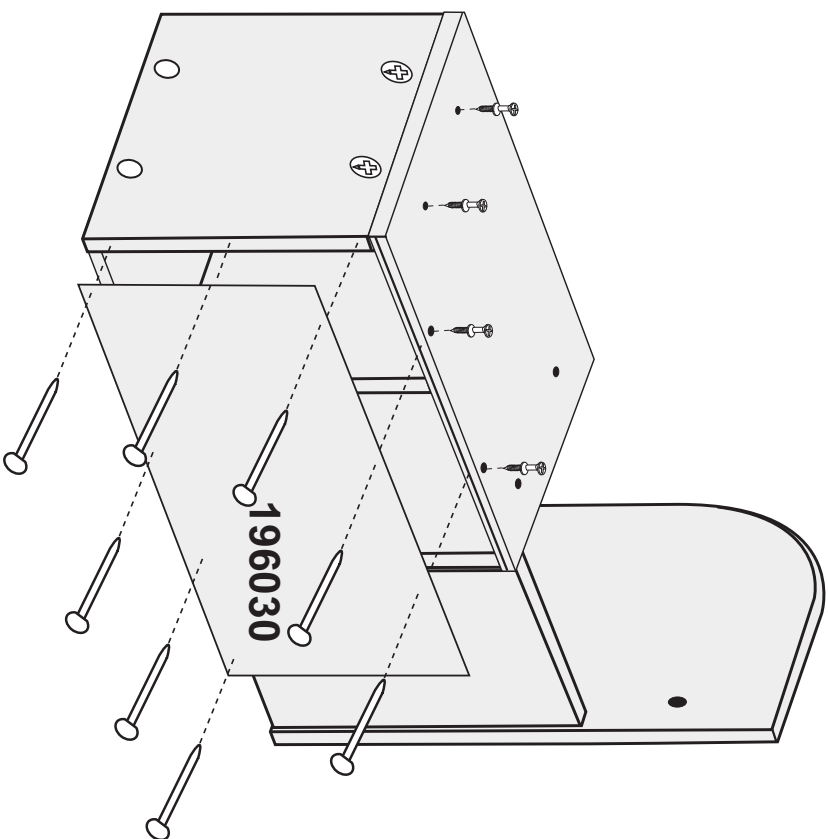

X30
P1030

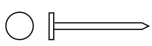

TCK0311



cm 0 1 2 3

X4



16b

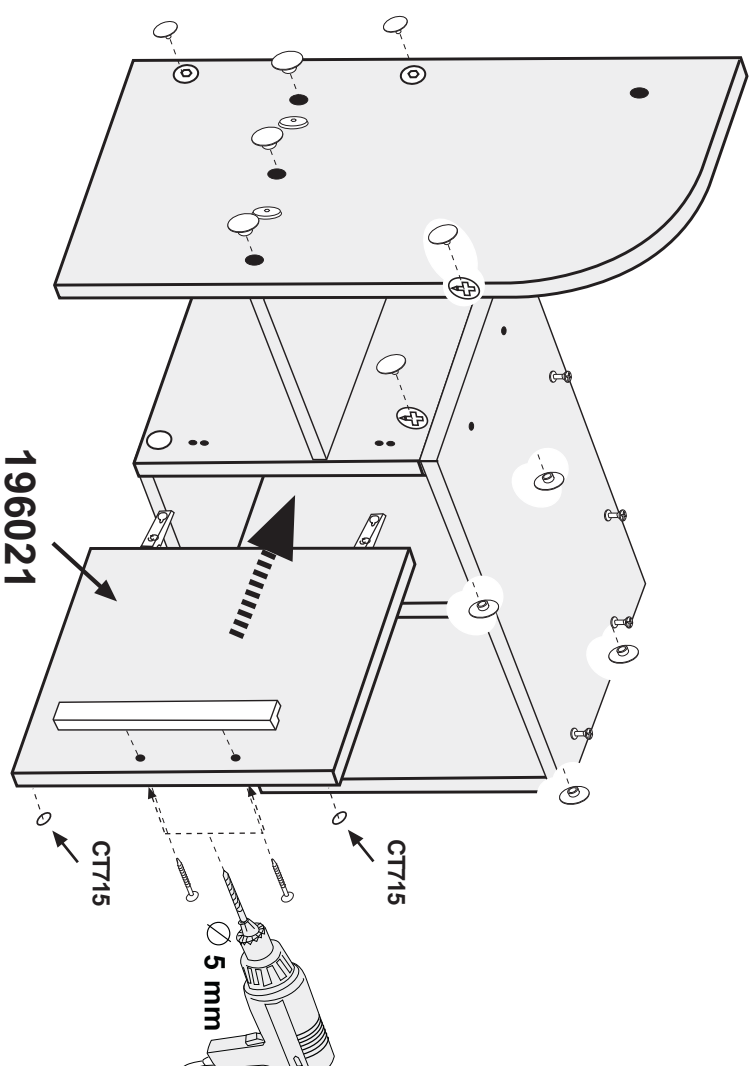

x1
AAM220

x2
TCK030

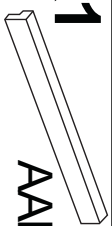

x1(2)
CT715

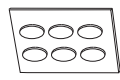

x3
T10RK



x2
TA4RK



x2
TE17BL



x4
TE17RK



17b



x2

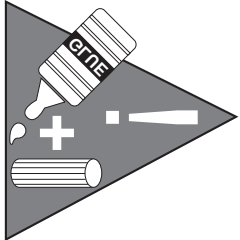

196004

196003

196002

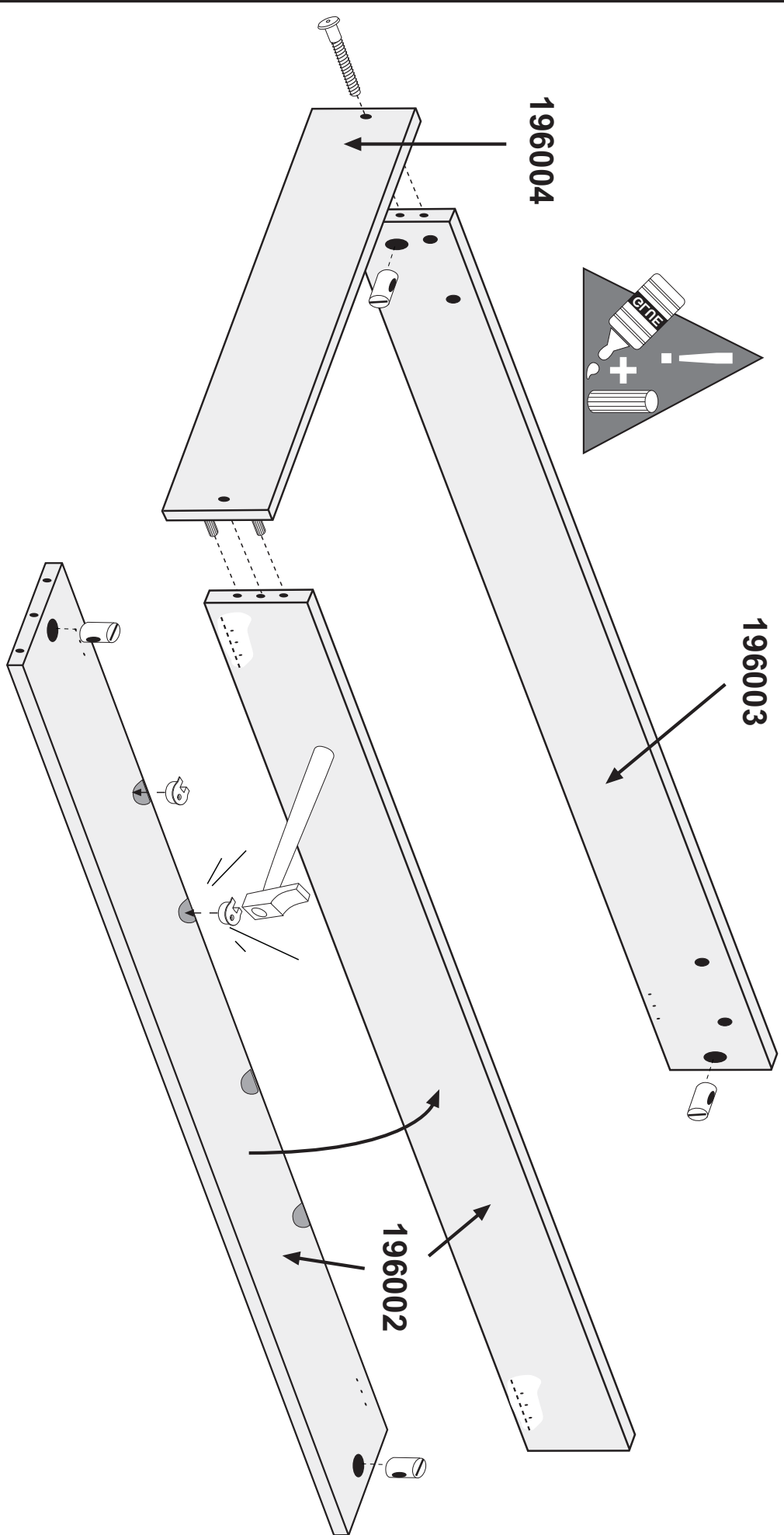
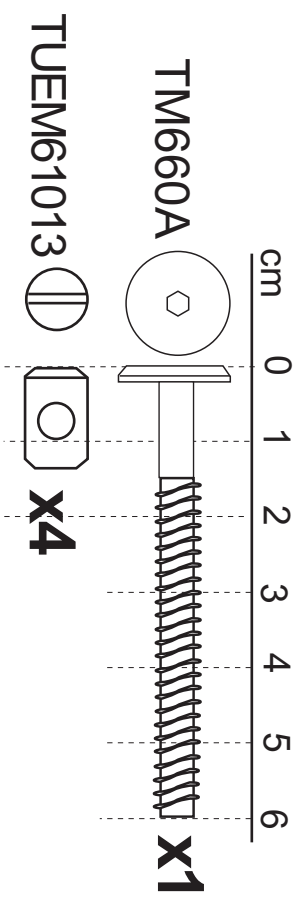

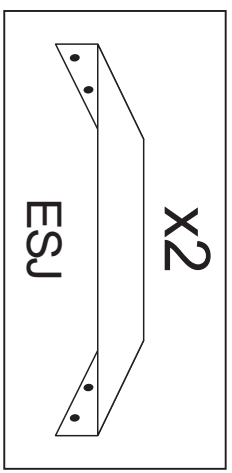
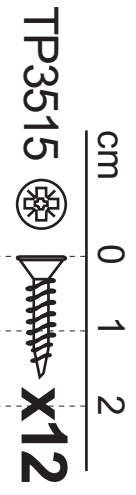
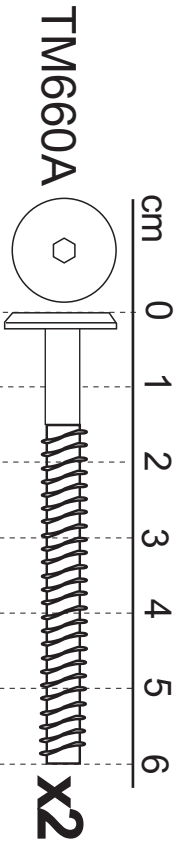
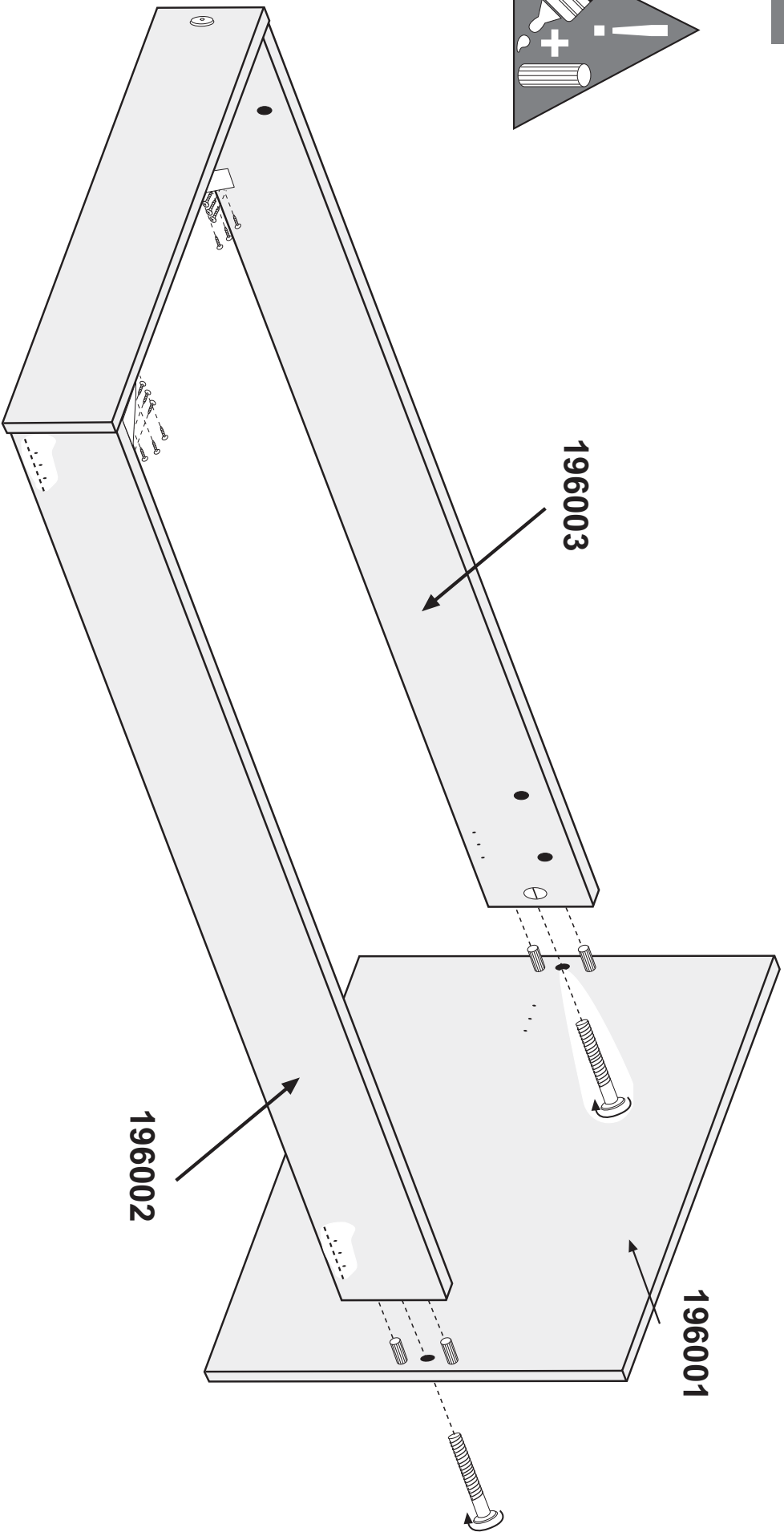
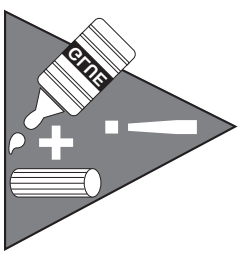

ESJ

cm 0 1 2 3 4 5 6

TM660A X1

TM630A X2

CM670 X2

196003

196001

196002

X2

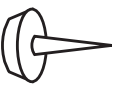

TSM

X2

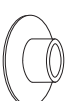

T8BL

X4

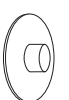

TA3RK

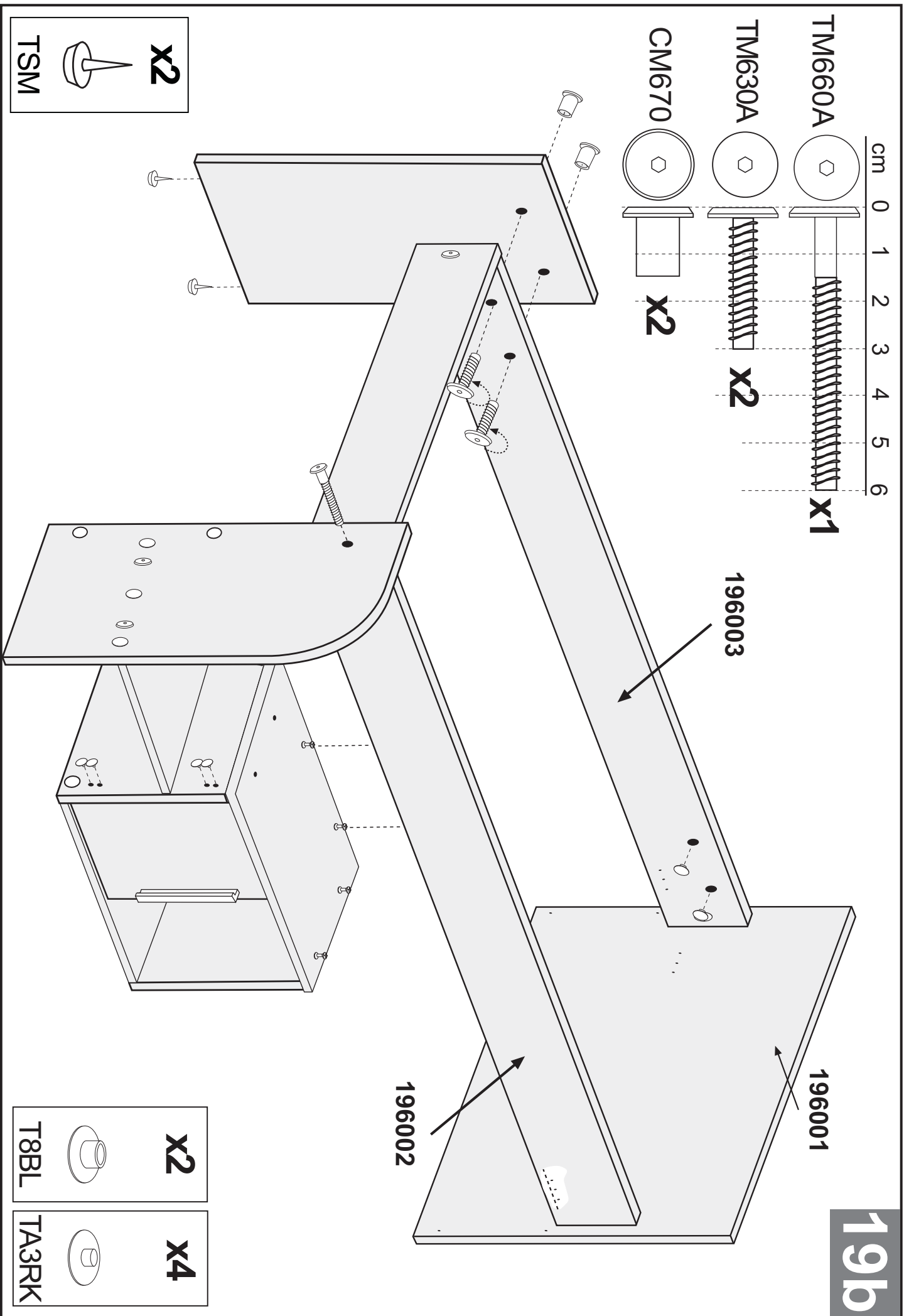

20b

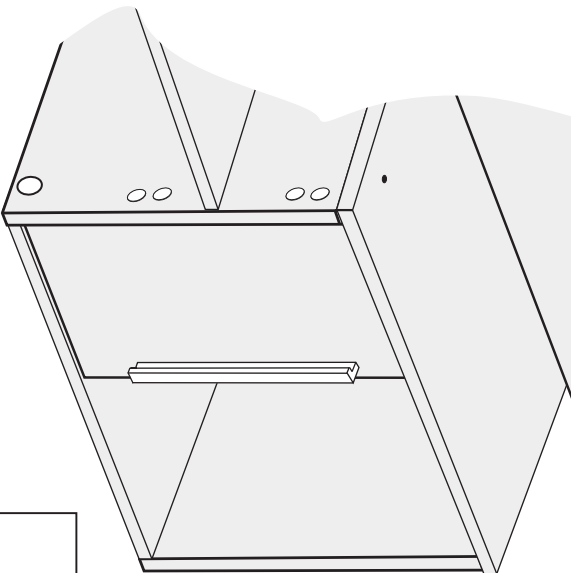
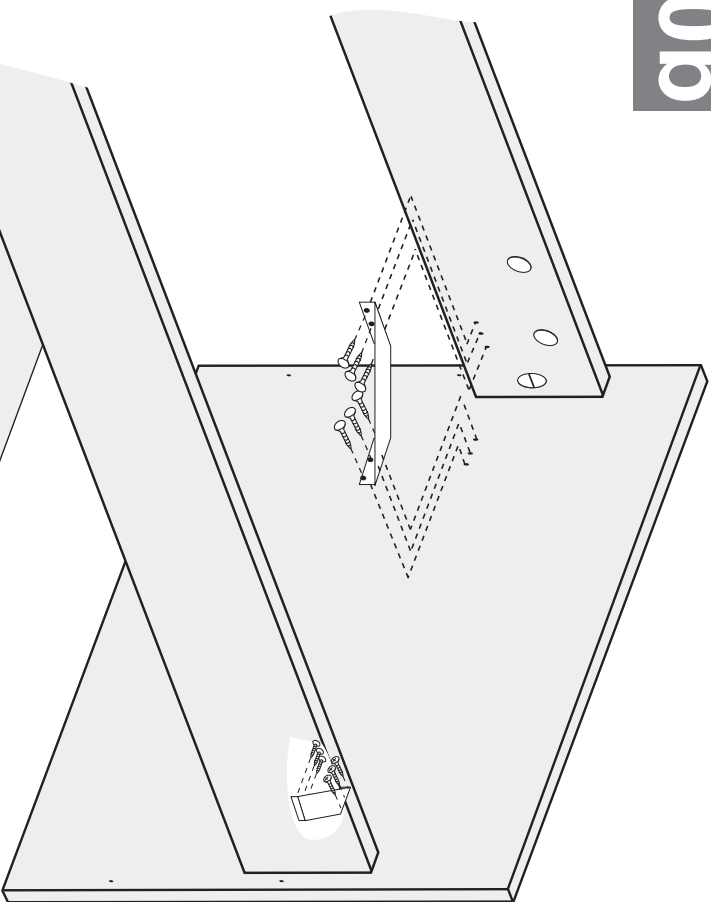

cm 0 1 2

TP3515 X12

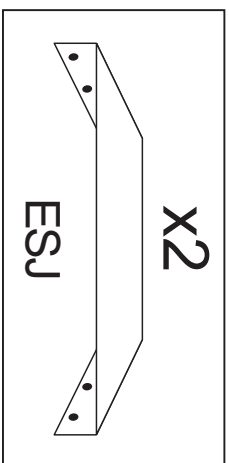

21b

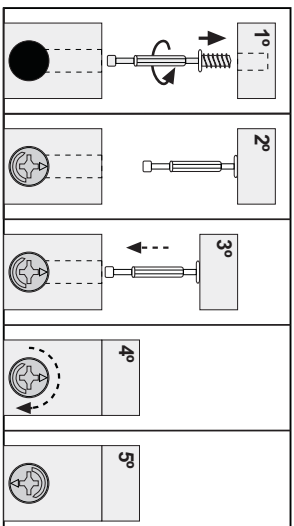
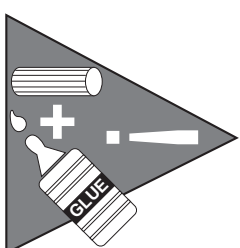
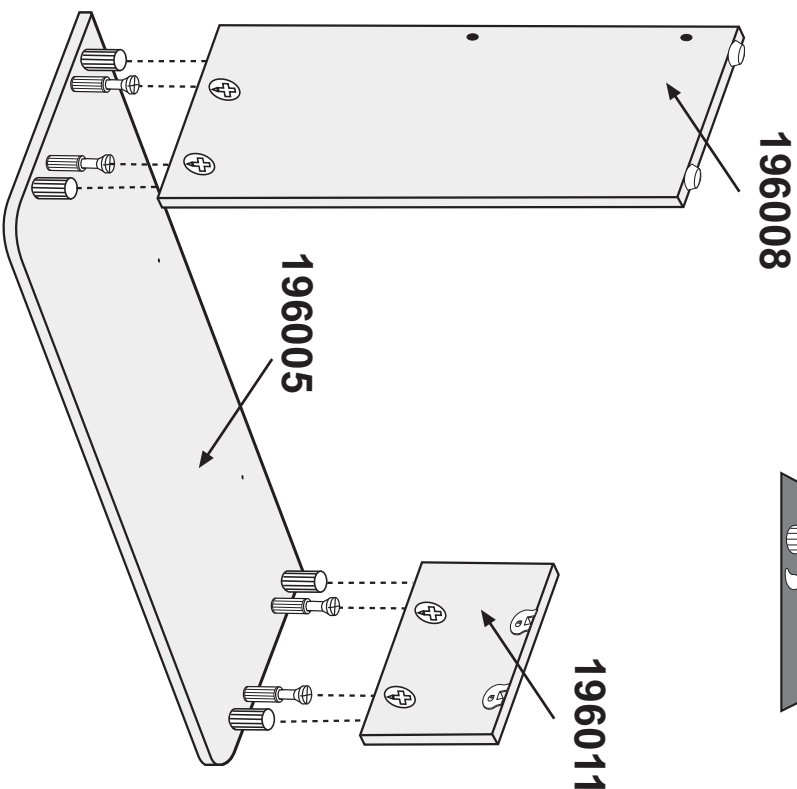

X2



TA3BL

X4



TE17RK

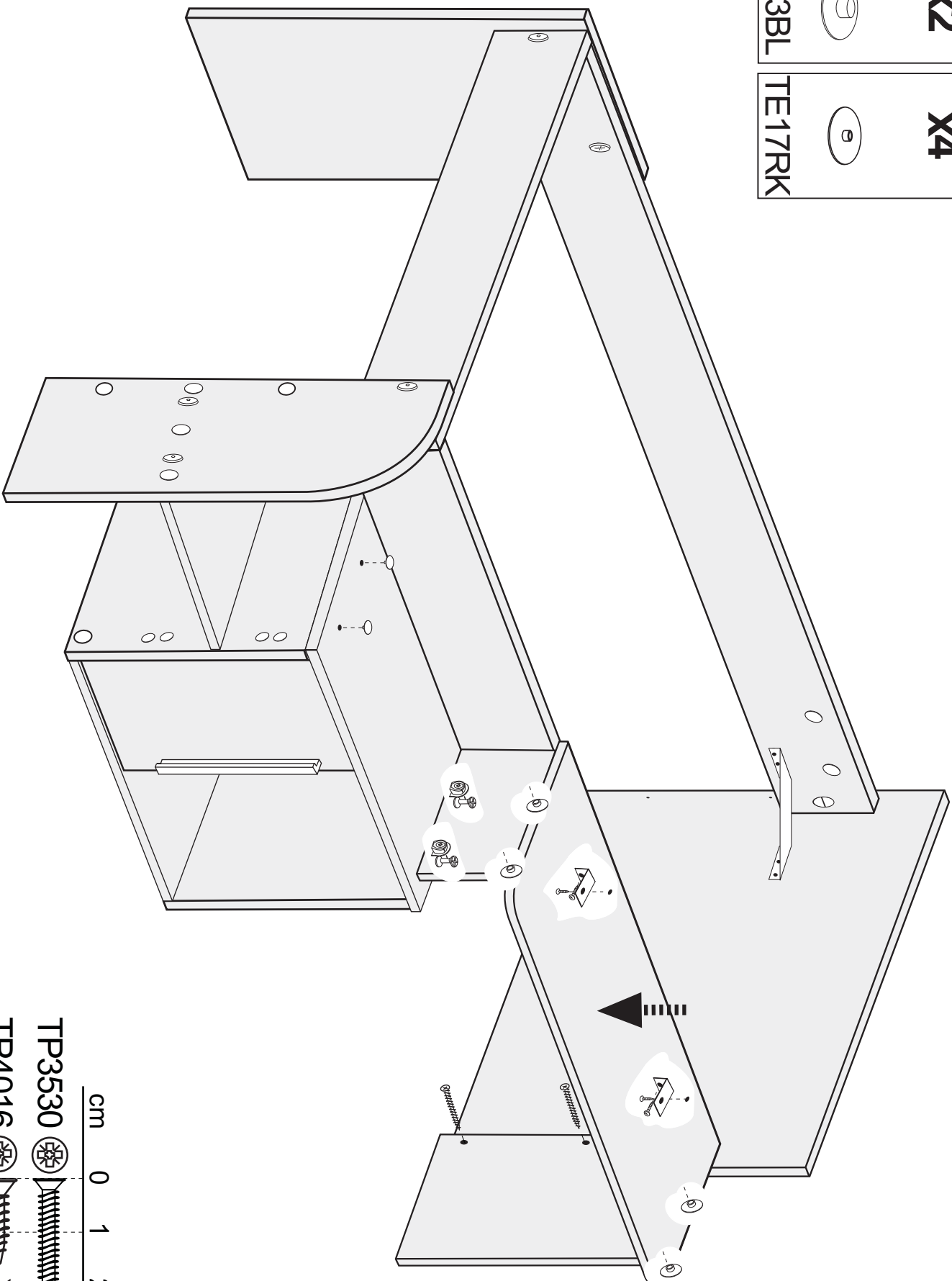

X2

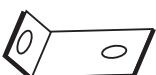

E2137

221b

cm 0 1 2 3

TP3530   **X2**

TP4016   **X4**

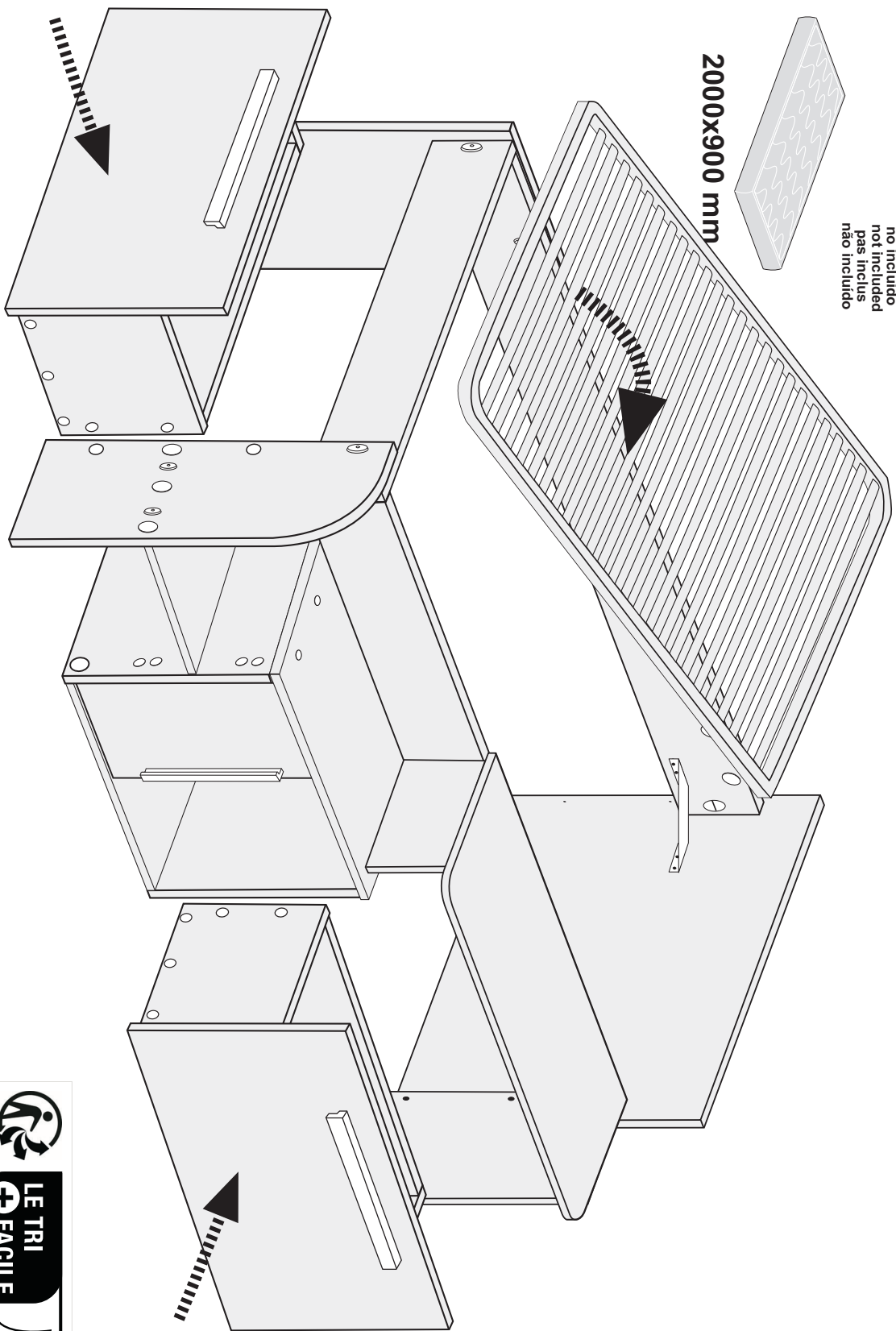

no included
not included
pas inclus
não incluido

2000x900 mm

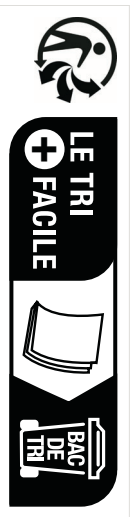

FR
Pensez à
donner ou recycler.



Association
ou
Magasin
ou
Déchetterie

<https://quefarredemesdechets.fr>