

Yardley Ottoman Single

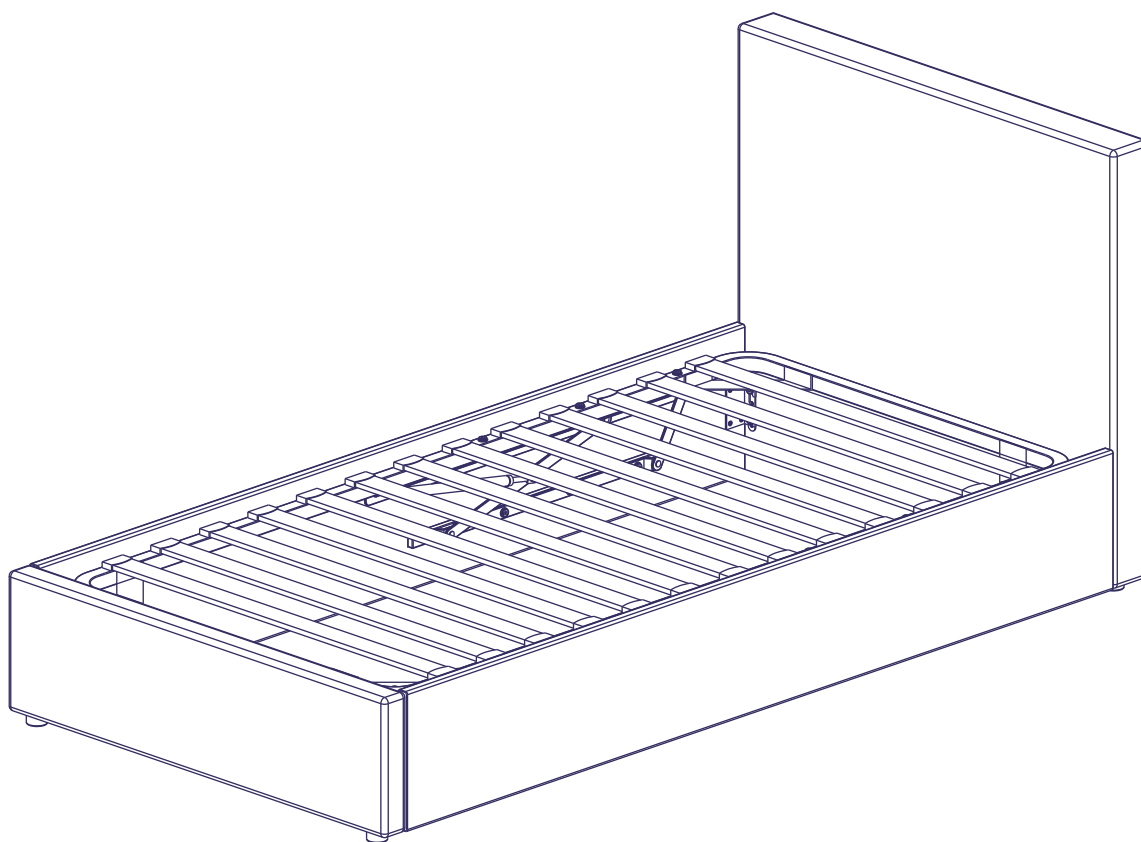

1/2 hour approx
assembly time



Two person
assembly

Dreams

Important Ottoman Safety Warnings

- IMPORTANT – READ CAREFULLY – RETAIN FOR FUTURE REFERENCE
- You must ensure that the mattress is on the bed frame before operating the lift mechanism – Failure to do so could result in injury.
- Keep hands clear of the mechanism when opening or closing the ottoman.
- Beware of entrapment – Never reach in through the mechanism to access the storage area.
- Always ensure that the ottoman is FULLY opened before accessing the storage area.
- Do not exceed the maximum weight as specified in the table below:

Bed	Bed Size	Piston Strength (N/M)	Min Mattress Weight (kg)	Max Mattress Weight (kg)
Yardley	Single	350	10	25
	Double	450	15	35



Thank you

Hello, thanks for choosing to purchase your bed from our company- you're now on your way to creating a practical and stylish solution for your room. Before you begin building your bed, please take a moment to read through the instructions and make sure that you've got all the relevant parts listed on the following pages.



Assembly tips

Before you begin, it's best to identify all parts and fittings to build your bed. We advise laying these out on the floor to check you have everything, and familiarising yourself before building.



Top tip

We recommend that you build your new bed in the room you'd like it to be located - this will help prevent any risk of damage to your newly built sofa bed whilst moving it.



Safety and care

It's really important to ensure children and animals are kept away from the assembly area, as there are small components used in this bed which could present a choking hazard. All plastic and wrapping materials should also be kept away from children and animals to prevent any risk of suffocation. To keep your little ones busy, there is a colouring page inside the back cover.



Help and support

At Dreams, it's our mission to give the whole nation a great night's sleep - this means that the quality of our products is of utmost importance to us. If there are any issues with your product or any missing parts, please contact our Help Centre on 0800 652 6750, where a member of our team will be happy to help. (For customers based in Northern Ireland, please call 028 9050 8300)



Recycling

Please ensure that packaging is disposed of in a safe and environmentally friendly way, and recycle where possible. Our assembly instructions are printed on recycled paper. Please keep your assembly instructions safe to refer back to in the future.

Parts



Before assembly the bed, please open the zipper at the back of headboard and find footboard(02),bottom cover(05) here.

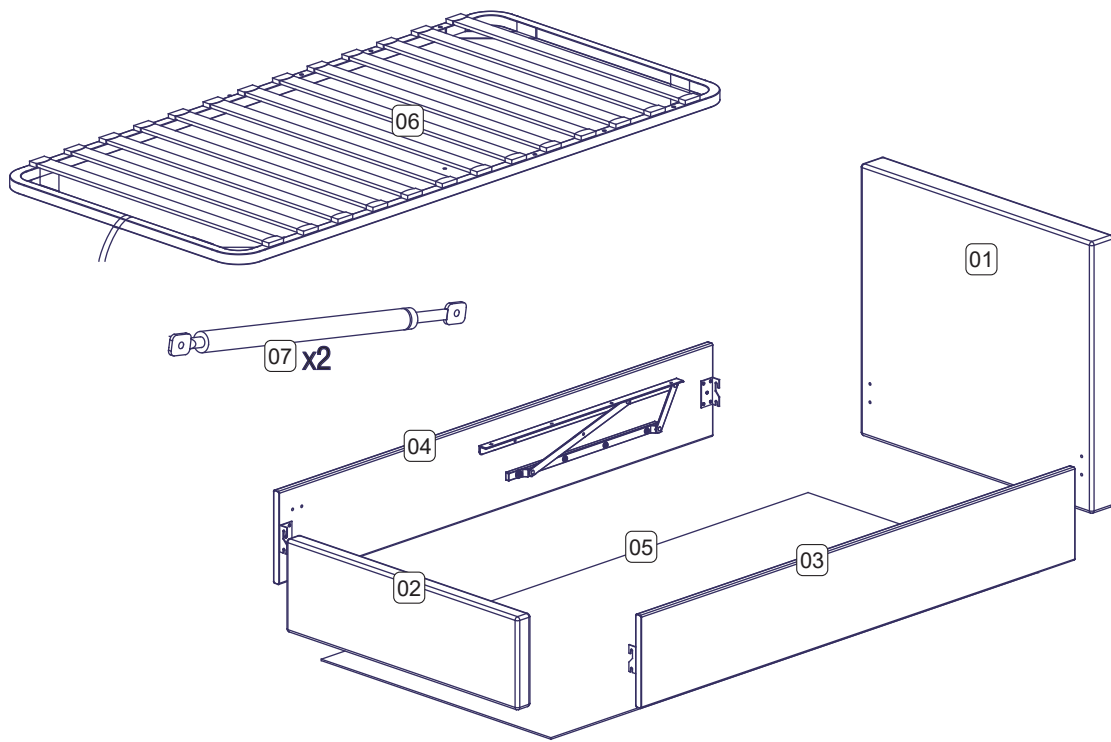

Parts list

1.	Headboard x1 pc	<input type="checkbox"/>	5.	Fabric base x 1 pc	<input type="checkbox"/>
2.	Footboard x 1 pc	<input type="checkbox"/>	6.	Metal slats frame x 1 pc	<input type="checkbox"/>
3.	Left siderail x 1 pc	<input type="checkbox"/>	7.	Gas piston x 2 pcs	<input type="checkbox"/>
4.	Right siderail x 1 pc	<input type="checkbox"/>			

Assembly

Fittings

Please check you have all the parts listed below with your product:

(A) x1



Spanner (M8)

(B) x16



Bolt (M8 x 20mm)

(C) x1



Allen Key

(D) x2

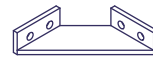

Metal Bracket

(E) x8



Bolt (M8 x 45mm)

(F) x16



Flat Washer

(G) x4



Nut (M8)

(H) x8



Nut (M8)

(I) x2



Black Soft Mat



Tools required

Please check you have all these below:



Tape measure



Scissors

Assembly

1

BED FRAME ASSEMBLING

Loosely insert bolts (B) into each side of headboard (1) and foot board.

Note: Do not tighten fully but leave 10mm protruding.

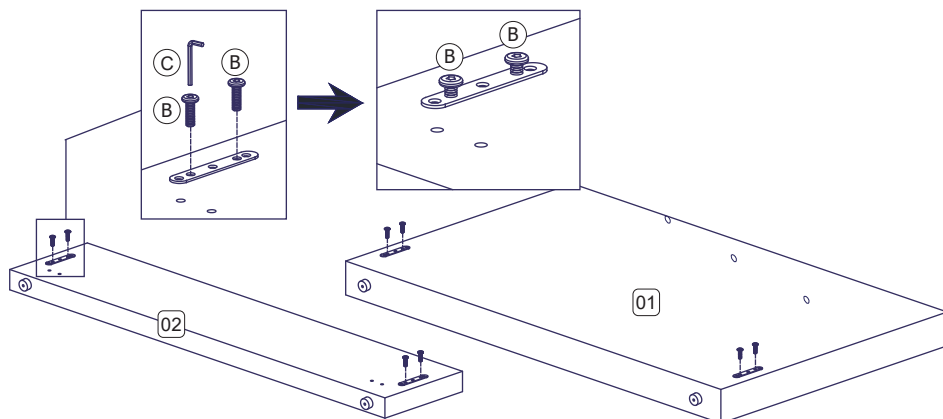

2

Attach the side rails to the headboard and footboard. Make certain the bed is squared up, then tighten all bolts fully.

Attach the corner brackets to the headboard and footboard. Stick the black soft mat on the corner brackets.

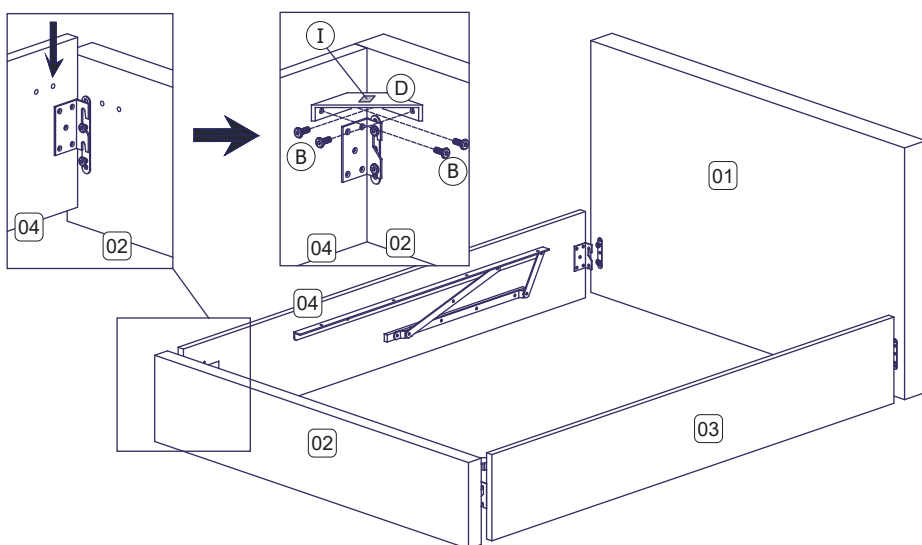

3

Turn the bed on its side and attach the fabric base to the bottom of the side rails, headboard and footboard.

Note: Make sure the fabric is fixed evenly all around.

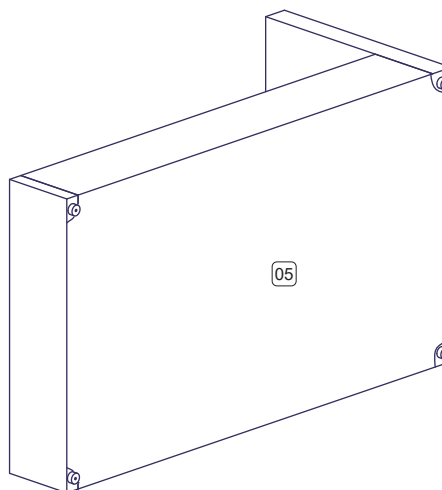

Assembly

4

Put the slat frame on the lift mechanism, use four sets of bolts (E), flat washers (F) and nuts (H) to loosely fit the slat frame to the first four holes on each side of the lift nearest to the headboard, finger tight.

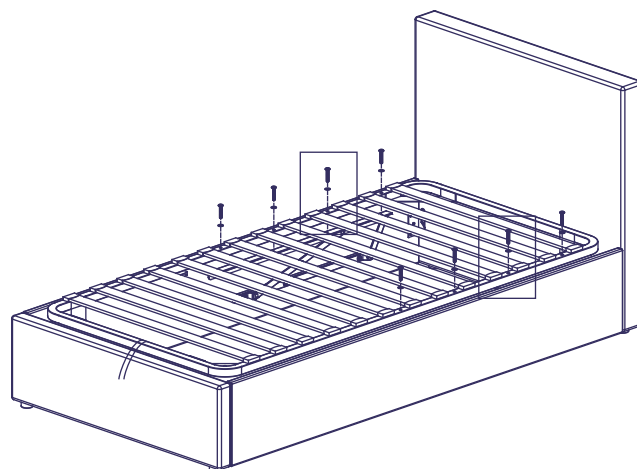
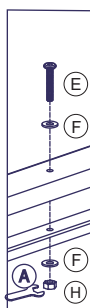

Tighten all the bolts after confirming the metal frame is in correct position. Frame must be in the center of bed in length & width.

5

Lift up the slat frame, use the locking nut (G) to fit the pistons to the lift mechanism.

Note: A small gap is left so stem can move freely. This is normal, See the sketch.

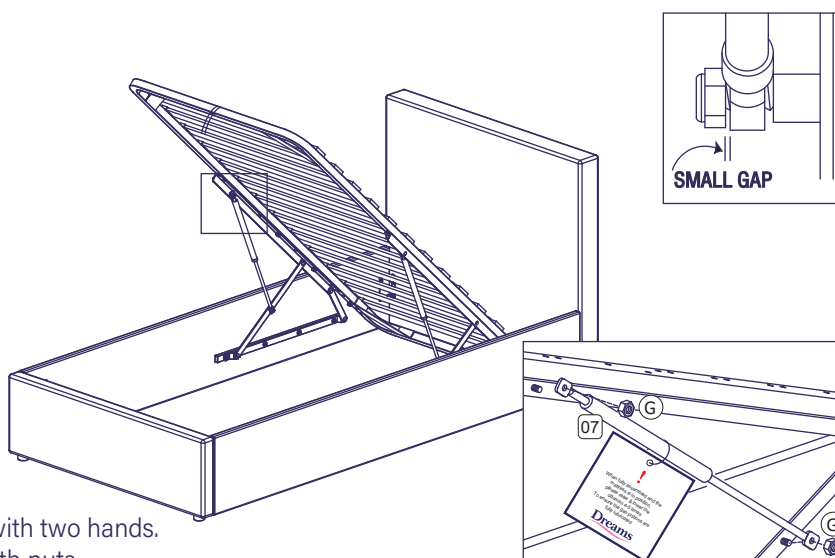

Lift up the slat frame by one person with two hands. Another one assemble the gas lift with nuts. Don't over tighten, a small gap is left so stem can move freely.

6

NOTE: When fully assembled and the mattress is in position, please raise and lower the ottoman 4-5 times. To ensure the gas pistons are fully lubricated.

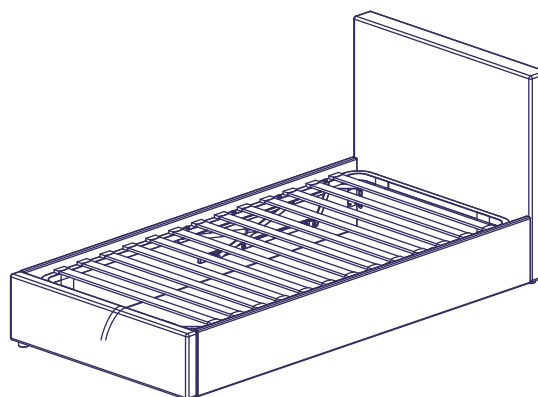

How to use Ottoman Support Bar

1

Before accessing the ottoman storage area, always ensure the ottoman support bar is engaged.

When engaging the ottoman support bar, ensure the slat frame/ platform base is raised to the maximum opening extension point i.e. the uppermost height.

Locate the support bar from the inside of slat frame / platform base.

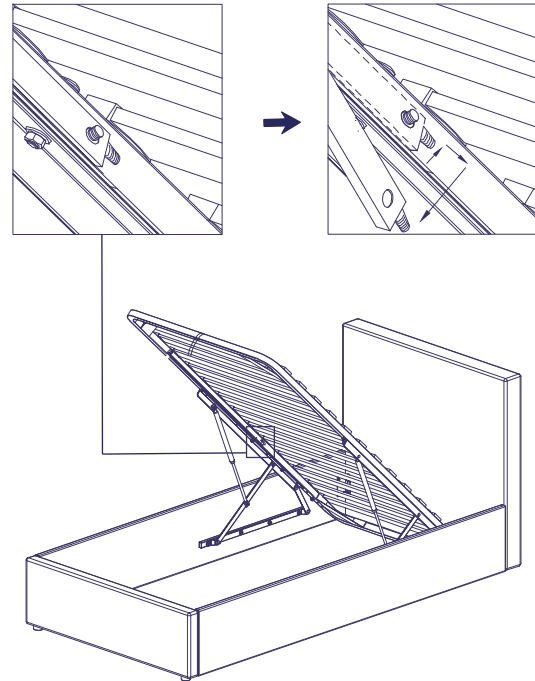

2

Put the support bar into the bracket fixed to the bed frame fully.

When you are ready to close the ottoman, carefully locate the support bar and lift it upwards out of the bed frame bracket and guide it back to inside of the slat frame and secure it.

Slowly close the ottoman slat frame / platform base using the handle provided.

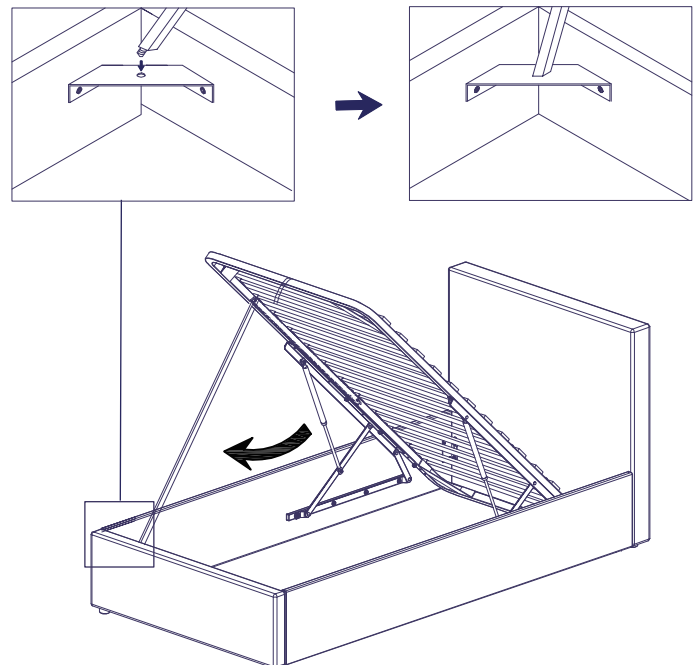

- Recommended mattress weights - do not exceed the maximum relevant weight specified on the Assembly Instruction.
- Ottoman support bar - always engage the support bar when accessing the ottoman storage area.
- Read all instructions provided before using your Ottoman bedframe. Please save and retain the instructions for future reference.

Warnings

- You must ensure that the mattress is on the bed frame before operating the lift mechanism – Failure to do so could result in injury.
- Keep hands clear of the mechanism when opening or closing the ottoman.
- Beware of entrapment – Never reach in through the mechanism to access the storage area.
- Always ensure that the ottoman is FULLY opened before accessing the storage area.
- Do not exceed the maximum weight as specified in the table below:

Bed	Bed Size	Piston Strength (N/M)	Min Mattress Weight (kg)	Max Mattress Weight (kg)
Yardley	Single	350	10	25
	Double	450	15	35

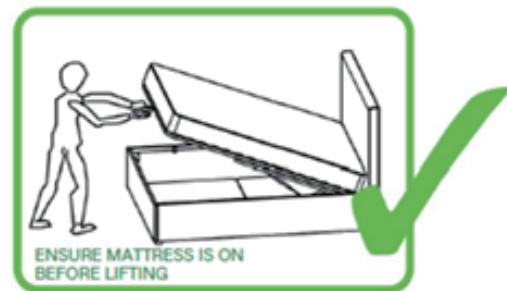

- Use caution when operating, always use the handle when lifting
- Note: This bed uses a pressurised mechanism.
- To be operated by adults only
- Please ensure that children and pets are kept away from the bed when operating the lift mechanism.
- Keep children and pets away from the storage area.
- Do not overload the internal storage base.
- Do not stand inside the internal storage area of the bed
- Before removing the mattress secure the frame to ensure it does not open unexpectedly.
- Do not attempt to lie on the mattress when the ottoman is in the raised position.
- When lifting the ottoman remove all bedding except the fitted sheet.

Care and maintenance

Here are some tips to keep your new bed in tip-top condition



Cleaning

To clean your new bed, we'd advise using a warm damp cloth - please do not use abrasive chemicals or bleach as this may damage the product.



Checking and moving

Periodically we recommend you check that the screws or fixtures haven't become loose, over time. To move your new bed, we recommend lifting it where possible, as dragging or pushing it could cause damage to your flooring.



Wood

Please note each of our wooden pieces are unique, meaning that markings and shade can vary slightly between beds. Over a period of time, the wood might lighten or fade slightly due to light exposure.



Fabric

Please note depending on the lighting, positioning and surroundings of your room, the shade of the colour can sometimes appear slightly different. Over a period of time, the colour might lighten or fade slightly due to light exposure.



Metal

Metal tends to be more resilient to everyday wear and tear. We recommend to gently dust your metal furniture and keep it dry to maintain its look.

Thank you for shopping with us - we hope you have a great night's sleep

Sleep well



Little dreamers

Keep the little ones entertained while you assemble your new purchase.



Dreams