

## Wilson ottoman single: ASSEMBLY INSTRUCTIONS

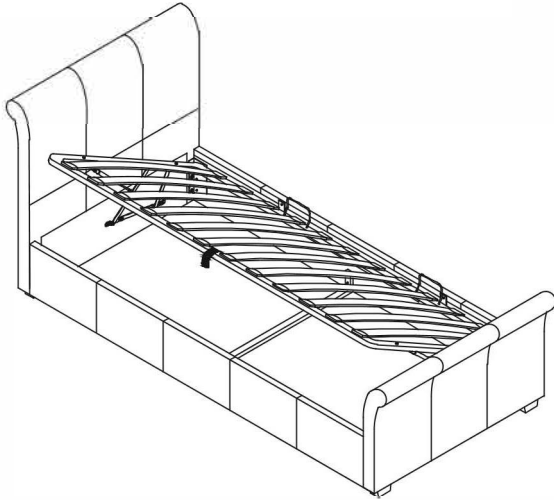

PLEASE READ this sheet prior to assembly to familiarise yourself with the various stages of construction. Carefully open the pack supplied and check the contents against the parts and fittings check list.

Do not destroy any of the packaging until you are certain that you have all the necessary parts for the assembly.

Please ensure that the packaging is disposed of in a safe environmentally friendly way.

CAUTION: There are small components used in the construction of this unit. These loose items should be kept away from young children during assembly, to avoid the danger of choking.

IMPORTANT: BEFORE STARTING TO ASSEMBLE THE BED - PLEASE READ THESE INSTRUCTIONS CAREFULLY



A full instructional video of the assembly of this bed is available via YouTube using the following address: <https://youtu.be/No3W3cH7nVU>

### Parts Identification

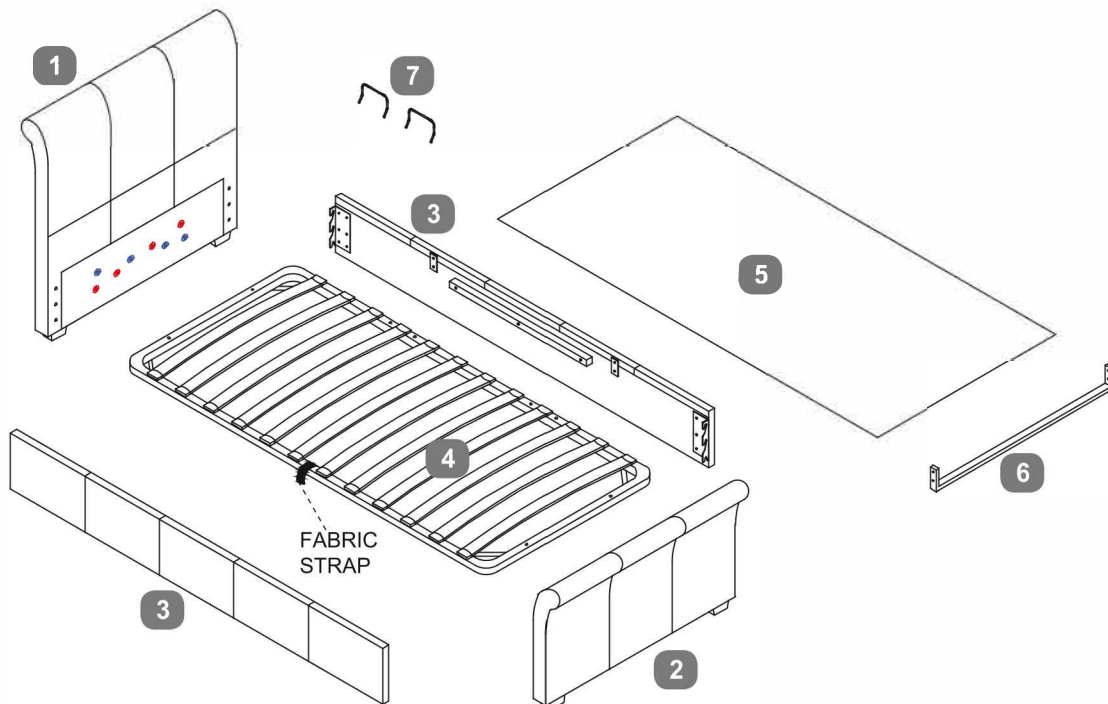

### Parts Checklist

Ref.	Description	Qty	Ref.	Description	Qty
1	Headboard	1	5	Base fabric cover	1
2	Footboard	1	6	'U' shaped cross bar	1
3	Side Rails	2	7	Mattress stoppers	2
4	Metal slat-frame	1			

## Fittings Checklist

### HARDWARE NEEDED FOR FITTING GAS-LIFT MECHANISMS (PACK A)

Code	Description	Qty	Code	Description	Qty
A	Bolts (M8x30mm) for fitting gas-lift mechanisms (M) to headboard & footboard (1&2)	x8	M (a)	Gas-Lift Mechanisms	x1
B	Spring Washers for M8 bolts	x8			
C	Flat Washers for M8 bolts	x8	M (b)		x1
D	Allen Key for M8 bolts	x1			

### HARDWARE NEEDED FOR BED ASSEMBLY (PACK B)

Code	Description	Qty	Code	Description	Qty
A	Bolts (M8x30mm) for fitting side rails (3) to headboard & footboard (1&2).	x12	C	Flat Washers for M8 bolts	x12
B	Spring Washers for M8 bolts	x12	K	Screws (5x50mm) for fitting 'U' shaped cross bar (6) to side rails (3)	x4

### HARDWARE FOR FITTING METAL SLAT FRAME (PACK C)

Code	Description	Qty	Code	Description	Qty
B	Spring Washers for M8 bolts	x4	F	Nuts (M8) for slat frame bolts	x4
C	Flat Washers for M8 bolts	x8	G	Flange Lock-Nuts (M8) for gas-lift pistons	x2
E	Bolts (M8x50mm) for fitting Metal Slat Frame (4) to slat frame support bars	x4	H	Spanner for M8 nut	x1

### Additional Tools Required

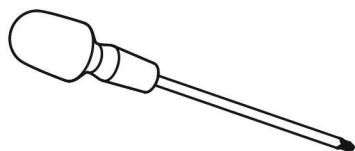

Cross-head Screwdriver

### Care & Maintenance

In the unlikely event of missing or damaged parts, please contact the customer service team on 0344 292 00 00. When calling this number, please quote the part code reference numbers shown in this leaflet when requesting spare or replacement parts.

### General Hints & Tips



Please retain your assembly instruction and tools provided for future use. Periodically check that all bolts are still tight.

Assembly requires two persons.



1 HOUR

Approximate time to assemble this product

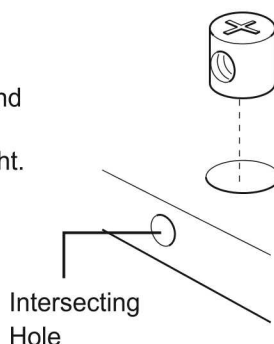

When they are supplied and are part of the assembly of this bed, ensure that the barrel nuts are fitted the correct way so the hole in the nut is facing towards the intersecting hole in the panel.

We recommend the bed is assembled in the room it shall be located in.

Stage  
1a

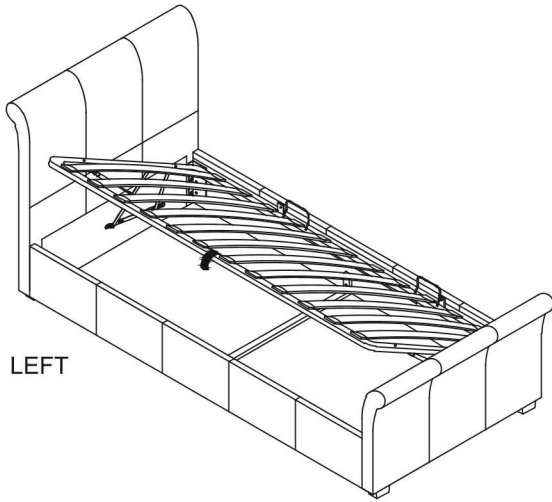
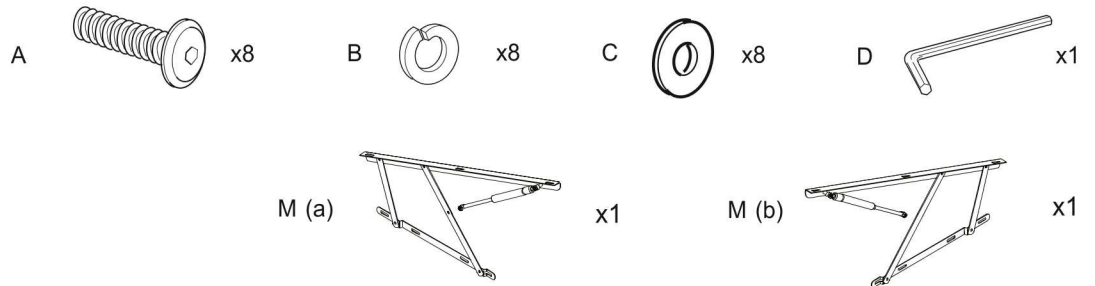

CHECK THIS DIAGRAM AND IF ACCESS IS NEEDED FROM LEFT SIDE OF BED, FIT BOTH LIFT MECHANISMS TO **RIGHT** SIDE OF THE BED. BOLT INTO THE HOLES MARKED (R) WITH BLUE LABELS. THE MECHANISMS ARE LABELED M (a) & M (b) PLEASE CAREFULLY FOLLOW THE DIAGRAM BELOW.

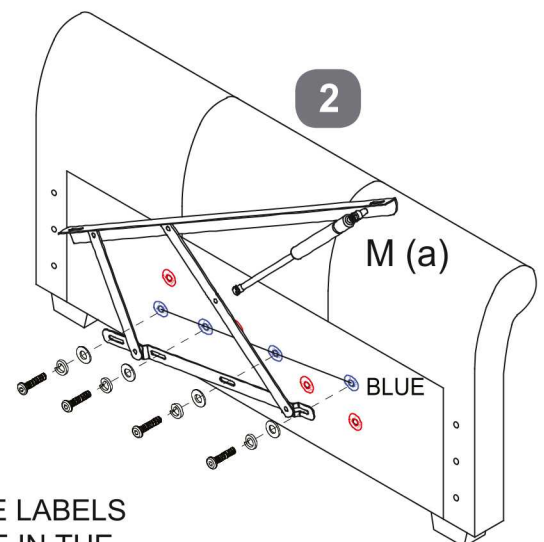
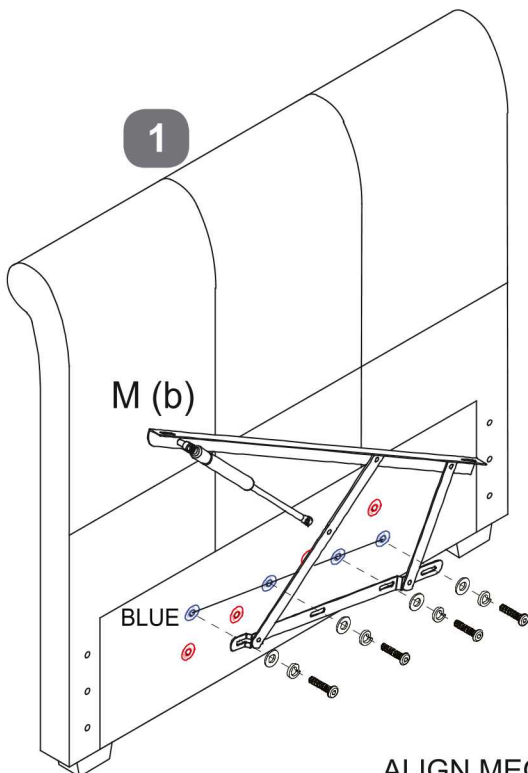
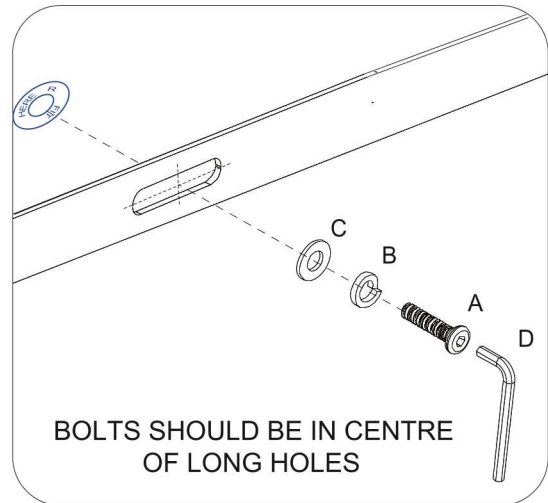

ALIGN MECHANISMS WITH BLUE LABELS  
MAKE SURE FIXING BOLTS ARE IN THE  
CENTRE OF THE LONG HOLES

# Fitting Gas-Lift Mechanisms- Use Pack 'A'

Stage  
1b

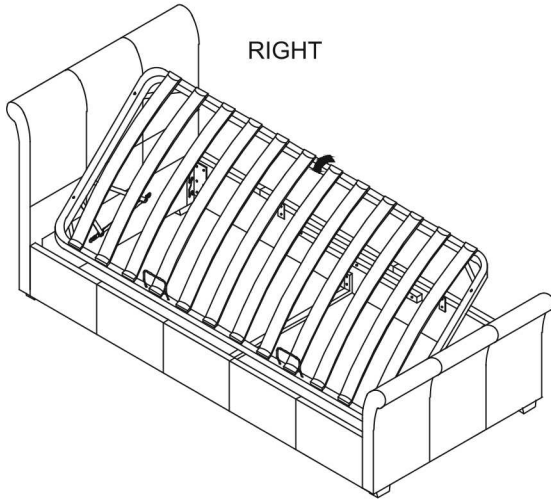
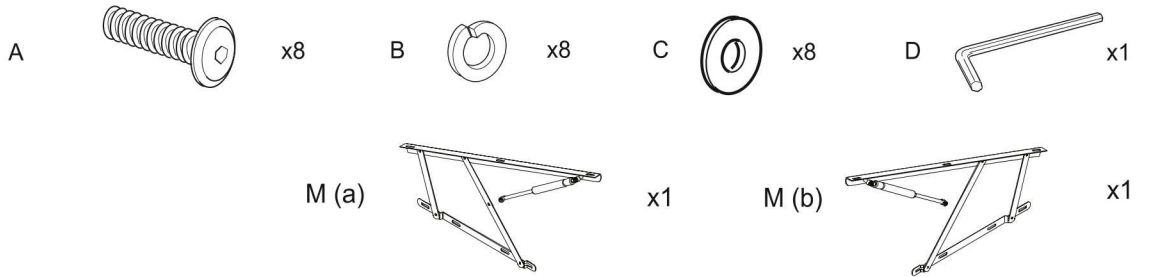

CHECK THIS DIAGRAM AND IF ACCESS IS NEEDED FROM RIGHT SIDE OF BED, FIT BOTH LIFT MECHANISMS TO **LEFT** SIDE OF THE BED. BOLT INTO THE HOLES MARKED (L) WITH RED LABELS. THE MECHANISMS ARE LABELED M (a) & M (b) PLEASE CAREFULLY FOLLOW THE DIAGRAM BELOW.

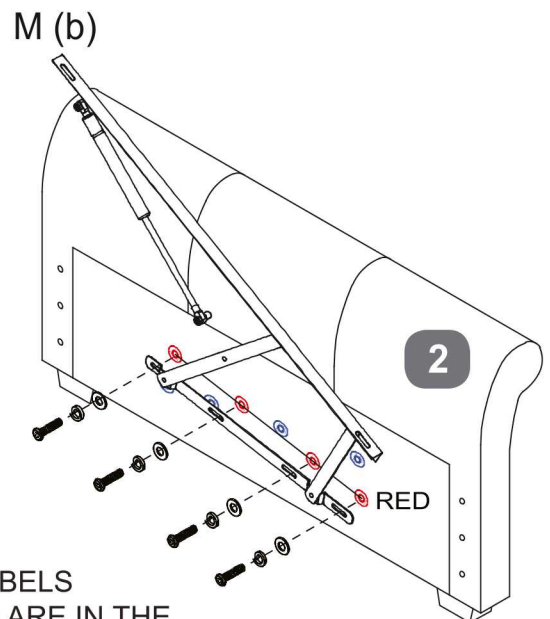
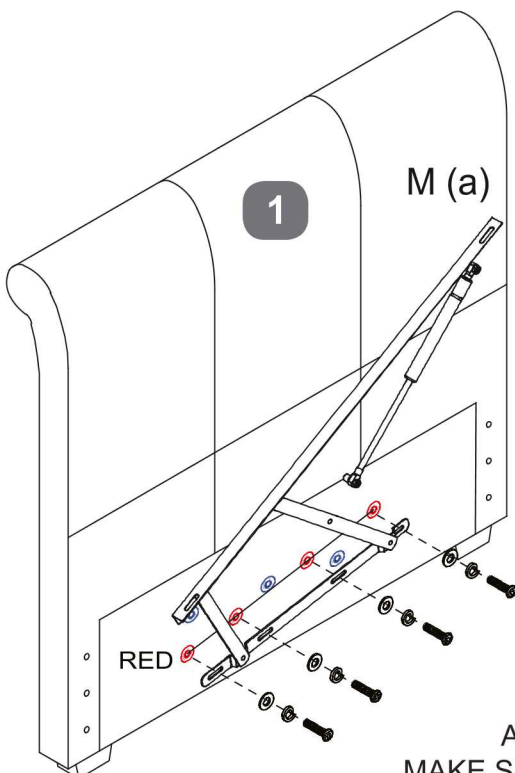
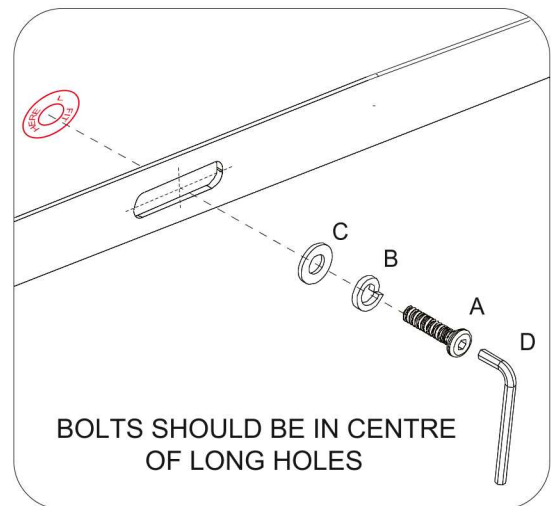

ALIGN WITH RED LABELS  
MAKE SURE FIXING BOLTS ARE IN THE CENTRE OF THE LONG HOLES



# Bed Assembly - Use Pack 'B'

Stage  
2



i) Loosely insert three sets of Bolts (A) with spring washers (B) & flat washers (C) into each side of Headboard & Footboard (1&2).

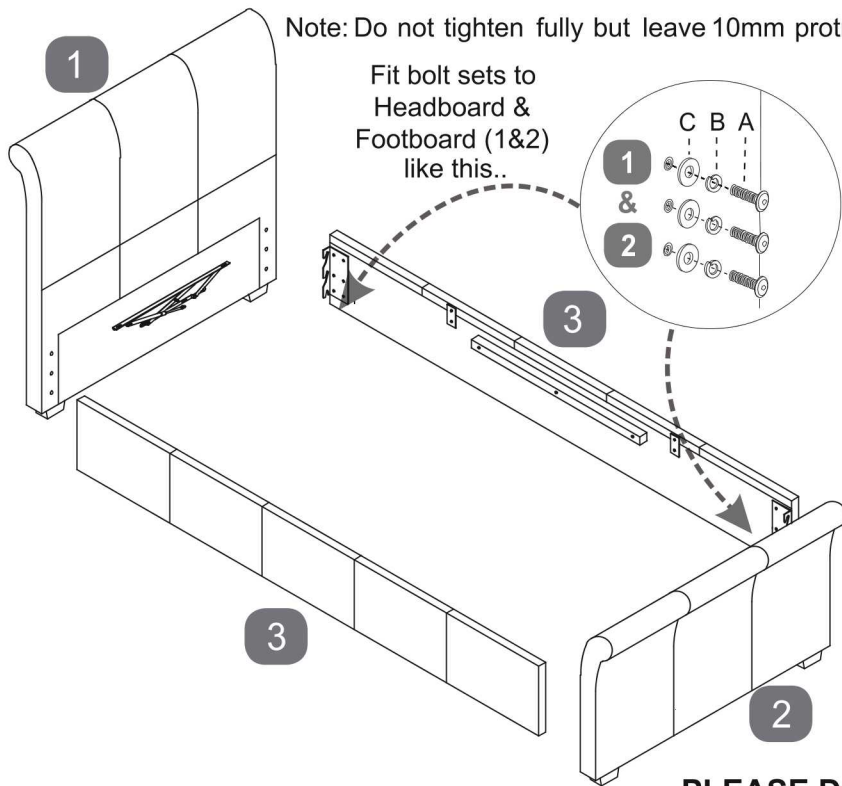

ii) Fit the side panels locating the brackets behind the flat washers.

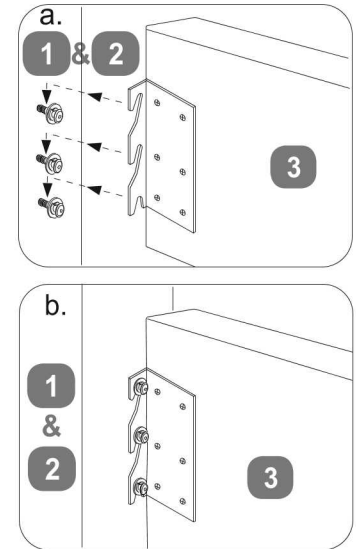

**PLEASE DO NOT TIGHTEN ANY BOLTS YET.**

Stage  
3

iii) MAKE CERTAIN THE BED IS SQUARED UP AS IN THE DIAGRAM.

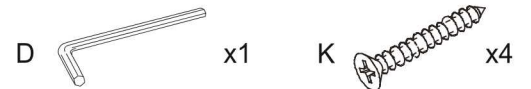
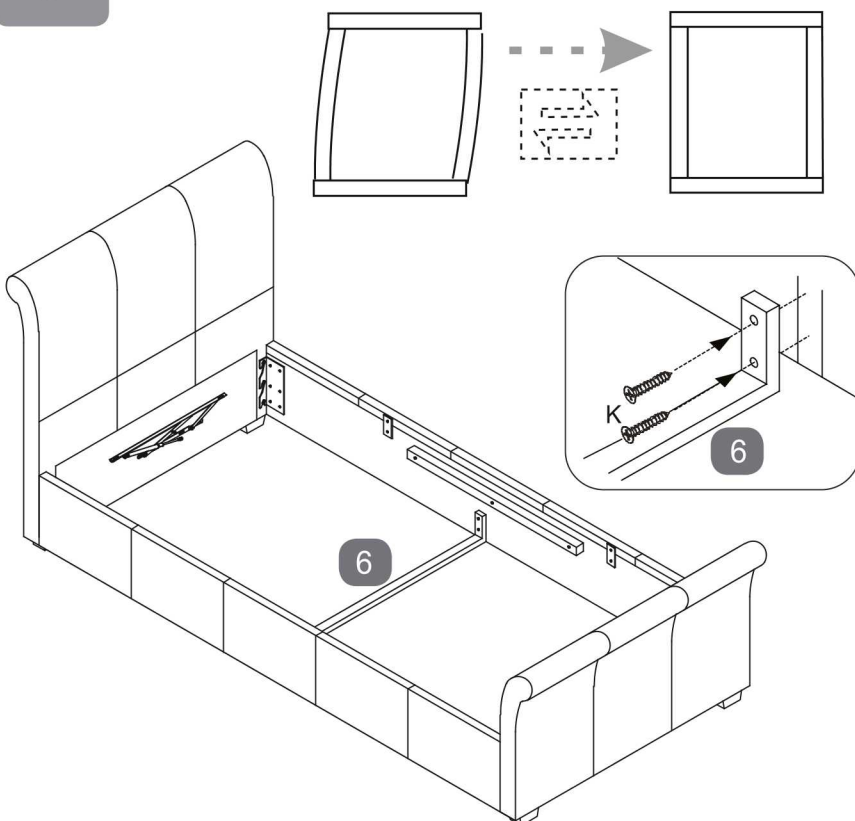

iv) Fit the 'U' Shaped Cross Bar (6) to centre of each side rails (3). Line up the ends of the bar between the two marked lines & fix into the side rails using screws (K). Note the screws drive straight into the side rail itself, there are no pilot holes.

v) Once all four corners are located tighten all the bolts using the allen key (D).

# Bed Assembly

Stage

4

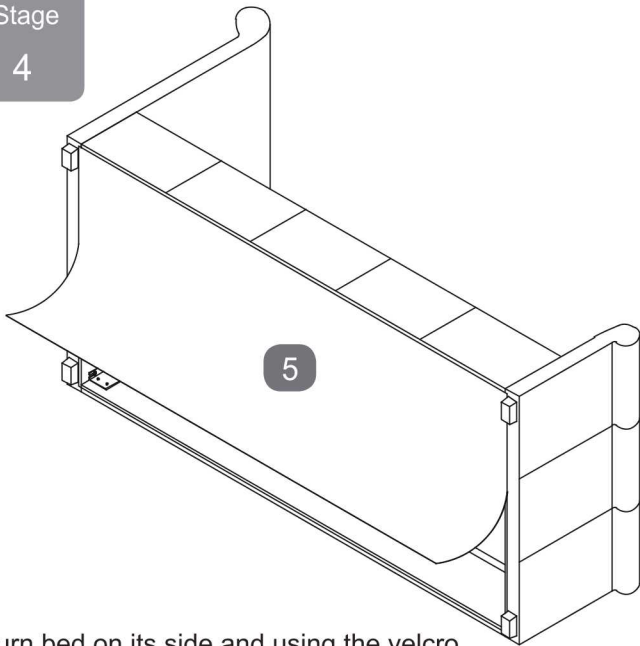

Turn bed on its side and using the velcro tape, carefully attach fabric base cover (5) to bottom of side rails, headboard & footboard making sure the fabric is fixed evenly all round.

Stage

5

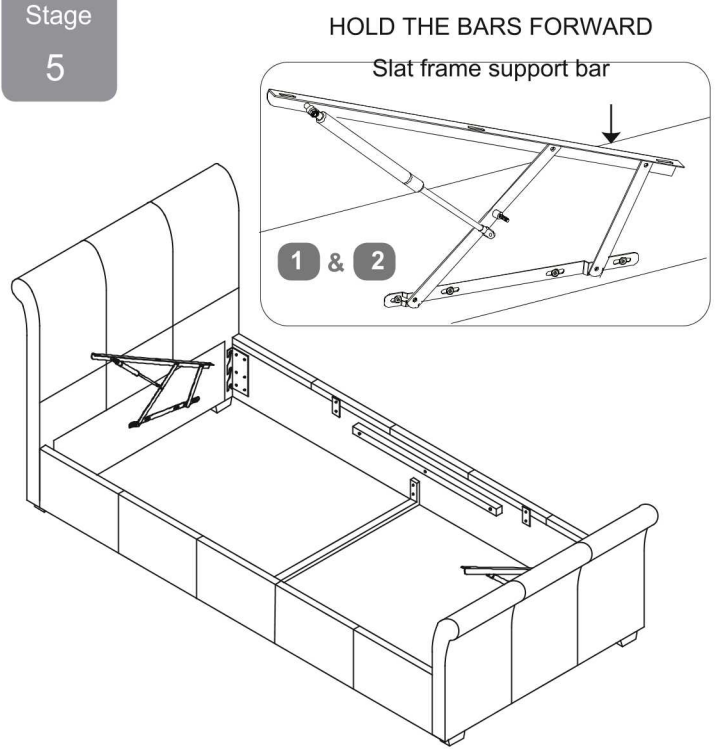

## Fitting Slat Frame - Use Pack 'C'

Stage

6

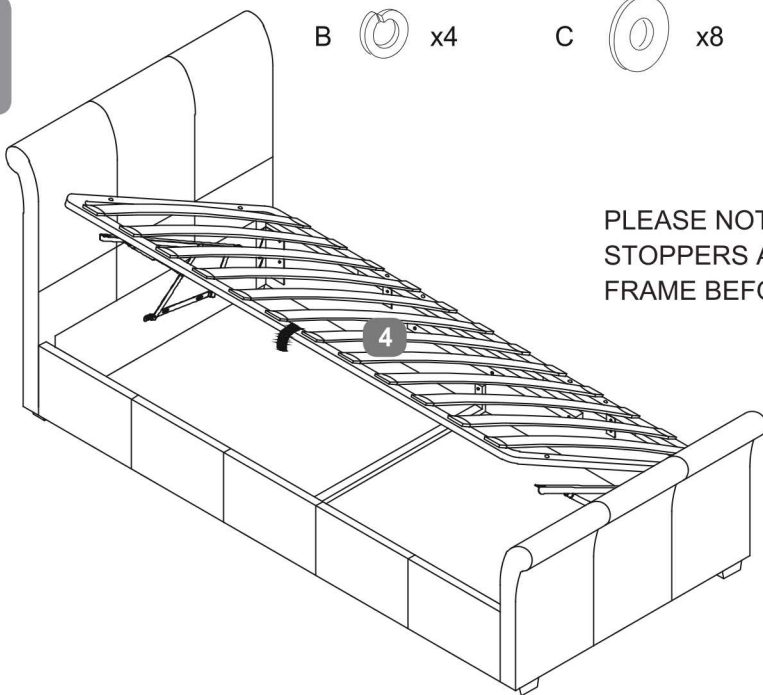

B  x4

C  x8

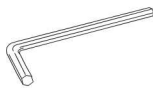
D  x1

F  x4

E  x4

H  x1

PLEASE NOTE: MAKE SURE THE HOLES FOR MATTRESS STOPPERS ARE ON THE CORRECT SIDE OF THE SLAT-FRAME BEFORE BOLTING TOGETHER.

- i) With help, lift slat frame (4) onto slat frame support bars.
- ii) Using two bolt sets on each side, (E), (C), (B) & (F), loosely fix slat frame to the six holes.

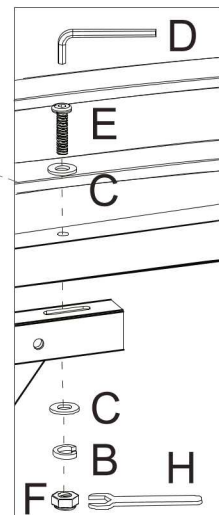
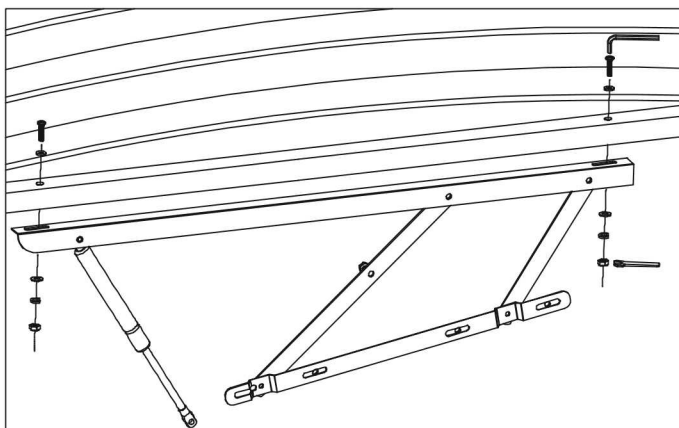

Stage  
7

D  x1    H  x1

Carefully lay frame down. Make sure there is an even gap each side of about 8mm, as in the sketch.

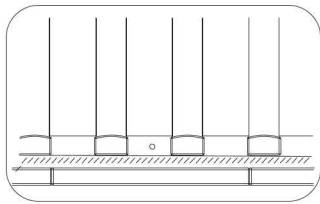
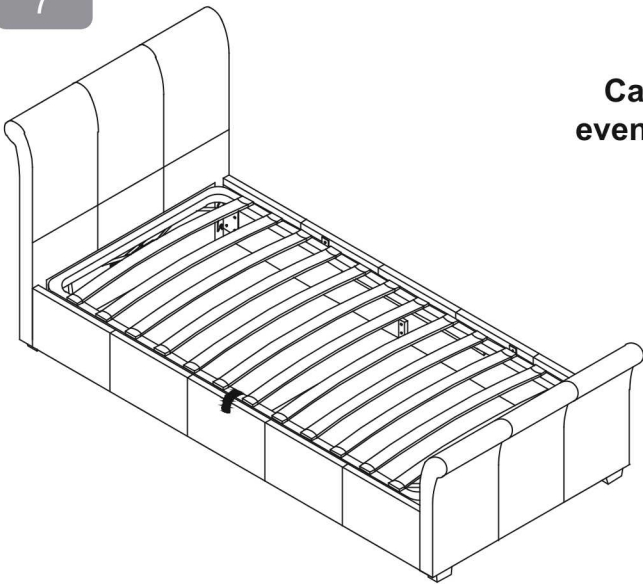

8mm

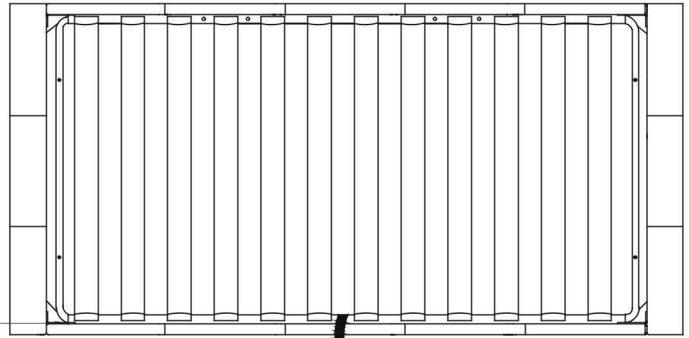

Hold frame then tighten all six bolt sets 100% using spanner (H) & allen key (D).

### Fitting Slat Frame - Use Pack 'C'

Stage  
8

G  x2    H  x1

Slide gas-lift piston stem onto the axle then fit the flange lock-nut (G). Tighten nut with spanner (H) - do not over-tighten. A small gap is left so stem can move freely - this is necessary - see sketch below.

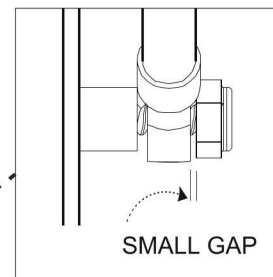
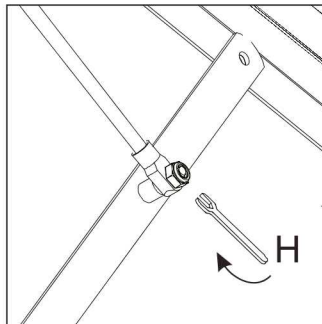
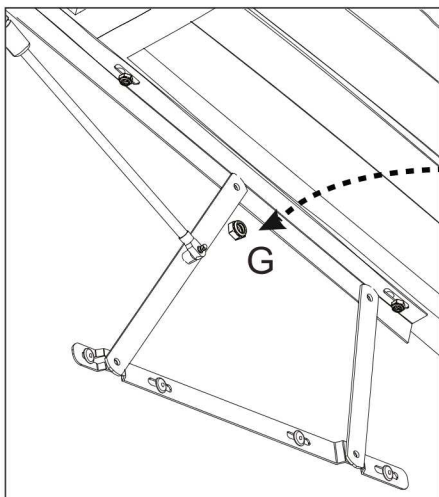
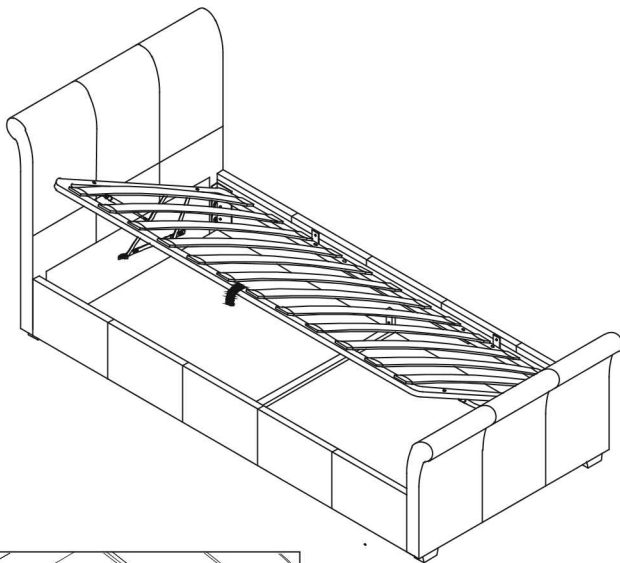



Stage  
9

Push x2 Mattress Stoppers (7) into metal frame, they should go all the way through the upper & lower metal sections.

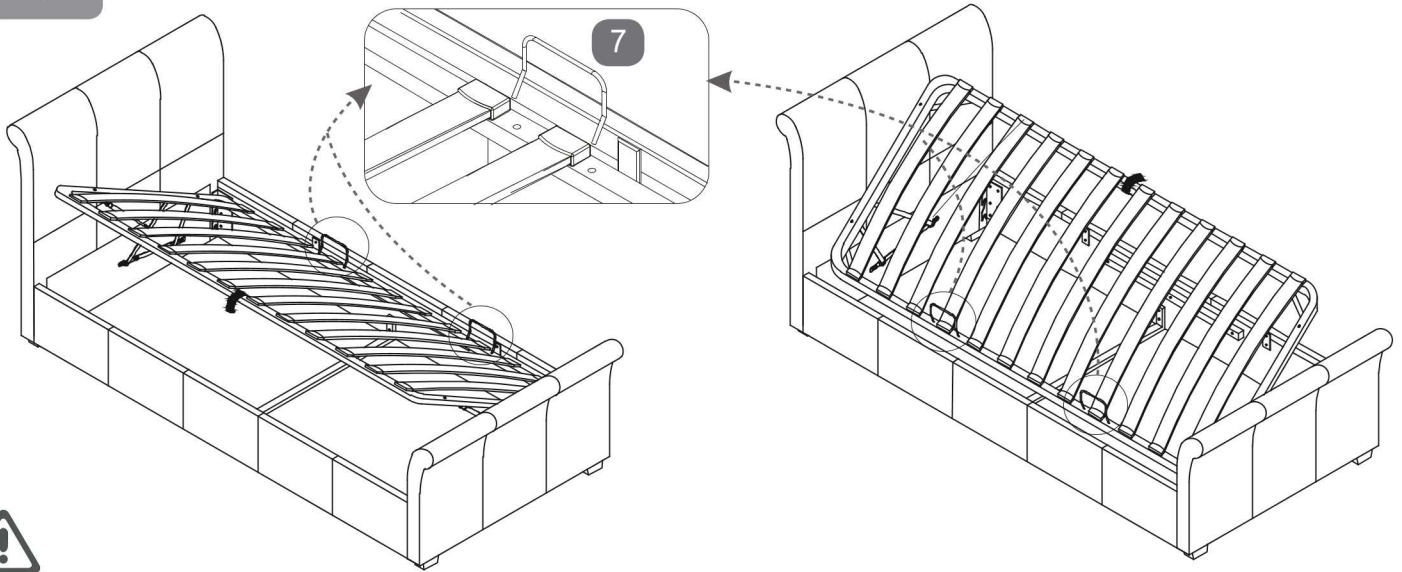

**NOTE:** Before moving the slat frame, place the mattress on the slats. Without a mattress in place, the speed of movement is quick and may cause injury. Carefully lower the frame with the hand-strap ensuring the frame sides are aligned with the side panels; there should be an even gap on each side. If not aligned, check bed is still square (see Stage 3) and if it is, but gaps are still not even, re-align as in Stage 7.

Depending on the weight of the mattress, the rising speed will vary so be careful until you get used to the speed. Always use the strap to lift or lower the frame - keep fingers well away from the moving parts.

**When fully assembled and the mattress in position, please raise & lower the ottoman 4/5 times to ensure the gas pistons are fully lubricated.**

Overall Dimensions (LWH cm)

Single: 222 x 99 x 108

Internal Storage Dimensions (LWH cm)

Single: 195 x 92 x 22

Distance between slats (cm)

Single: 9.3

