

PLEASE READ this sheet prior to assembly to familiarise yourself with the various stages of construction. Carefully open the pack supplied and check the contents against the parts and fittings check list.

Do not destroy any of the packaging until you are certain that you have all the necessary parts for the assembly.

Please ensure that the packaging is disposed of in a safe environmentally friendly way.

CAUTION: There are small components used in the construction of this unit. These loose items should be kept away from young children during assembly, to avoid the danger of choking.

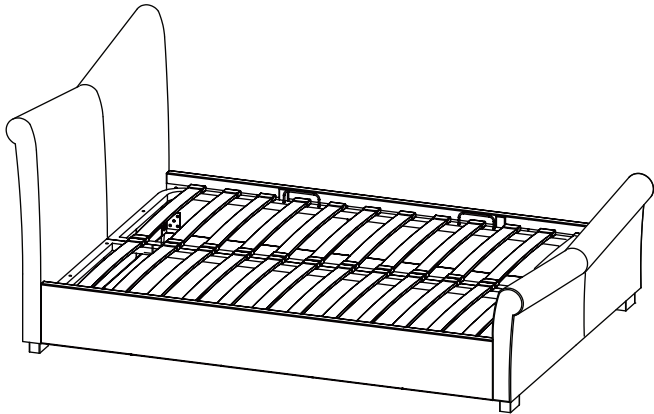

IMPORTANT: BEFORE STARTING TO ASSEMBLE THE BED - PLEASE READ THESE INSTRUCTIONS CAREFULLY



A full instructional video of the assembly of this bed is available via YouTube using the following address: <https://youtu.be/No3W3cH7nVU>

Parts Identification

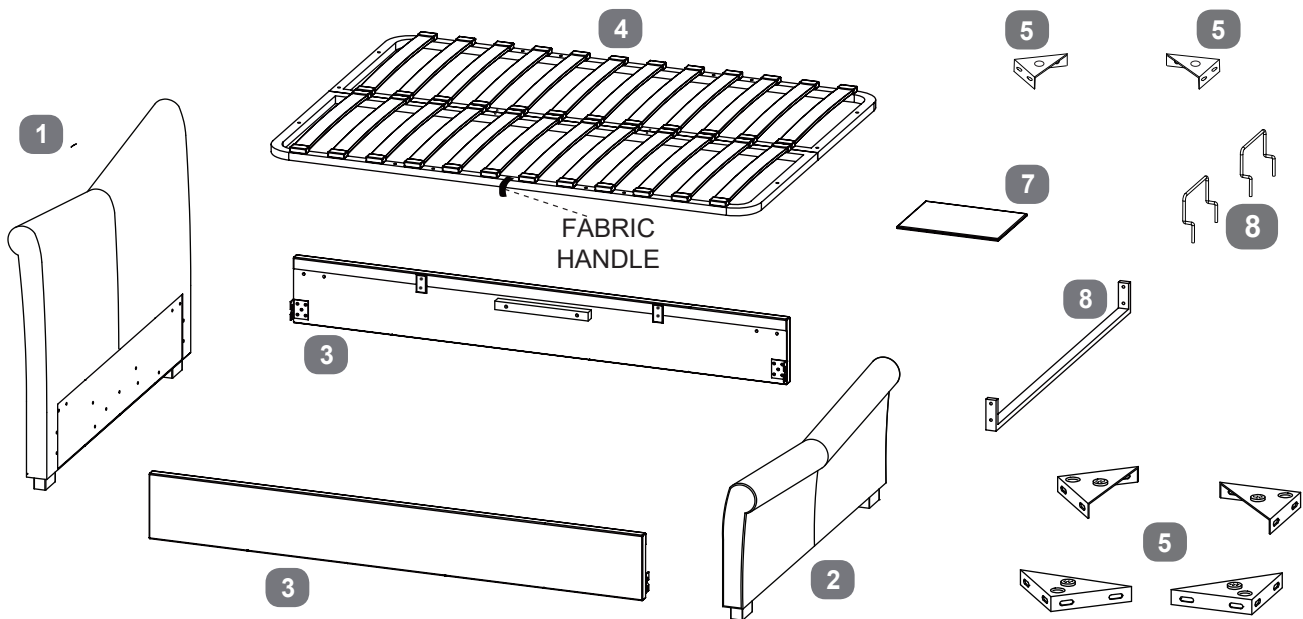

Parts Checklist

Ref.	Description	Qty	Ref.	Description	Qty
1	Headboard	1	5	Angle Brackets	4
2	Footboard	1	6	Mattress Stoppers	2
3	Side Panels	2	7	Fabric Base Cover	1
4	Metal Slat Frame	1	8	'U' Shaped Cross Bar	1

Fittings Checklist

HARDWARE NEEDED FOR FITTING GAS-LIFT MECHANISMS (PACK A)

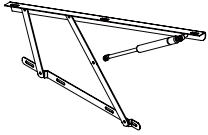
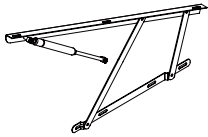
Code	Description	Qty	Code	Description	Qty
A	Bolts (M8x30mm) for fitting gas-lift mechanisms (M) to headboard & footboard (1&2)	x8	M (a)	 Gas-Lift Mechanisms	x1
B	Spring Washers (for M8 bolts)	x8			
C	Flat Washers (for M8 bolts)	x8	M (b)		x1
D	Allen Key (for M8 bolt)	x1			

HARDWARE NEEDED FOR BED ASSEMBLY (PACK B)

Code	Description	Qty	Code	Description	Qty
A	Bolts (M8x30mm) for fitting side panels (3) to headboard & footboard (1&2).	x24	C	Flat Washers (for M8 bolts)	x24
B	Spring Washers (for M8 bolts)	x24	K	Screws (5x50mm) fitting 'U' shaped cross bar (8) to side panels (3)	x4

HARDWARE FOR FITTING METAL SLAT FRAME (PACK C)

Code	Description	Qty	Code	Description	Qty
B	Spring Washers (for M8 bolts)	x6	G	Flange Lock-Nuts (M8) for gas-lift pistons	x2
C	Flat Washers (for M8 bolts)	x16	H	Spanner (for M8 nut)	x1
E	Bolts (M8x50mm) for fitting Metal Slat Frame (5) to slat frame support bars	x6	J	Bolts (M8x20mm) for fitting Metal Plates (K) to Metal Slat Frame (5)	x4
F	Nuts (for M8 slat frame bolts)	x6	K	Metal Plates (for M8 bolts)	x2

Additional Tools Required

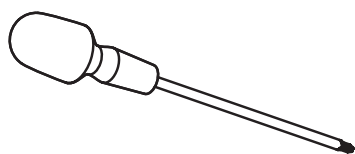

Cross-head Screwdriver

Care & Maintenance

In the unlikely event of missing or damaged parts, please contact the customer service team on 0344 292 00 00. When calling this number, please quote the part code reference numbers shown in this leaflet when requesting spare or replacement parts.

General Hints & Tips



Please retain your assembly instruction and tools provided for future use. Periodically check that all bolts are still tight.

Assembly requires two persons.



Approximate time to assemble this product

1 HOUR



When they are supplied and are part of the assembly of this bed, ensure that the barrel nuts are fitted the correct way so the hole in the nut is facing towards the intersecting hole in the panel.

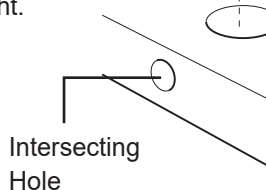

Intersecting Hole

We recommend the bed is assembled in the room it shall be located in.

Stage
1a

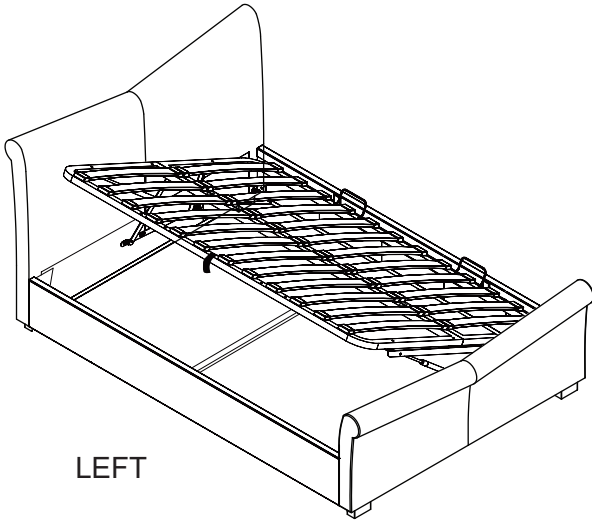
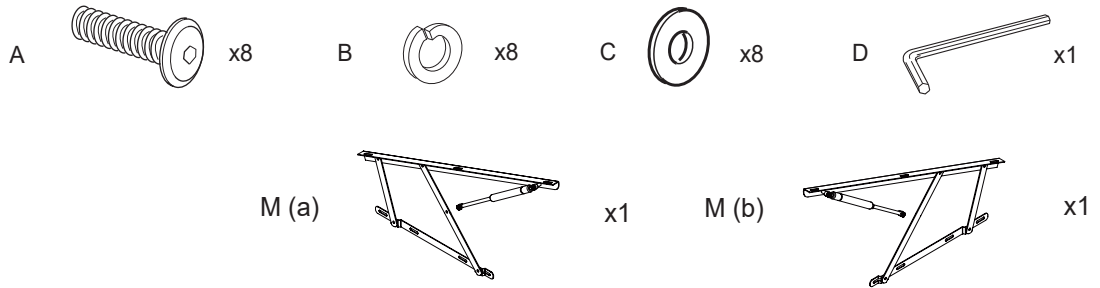

CHECK THIS DIAGRAM AND IF ACCESS IS NEEDED FROM LEFT SIDE OF BED, FIT BOTH LIFT MECHANISMS TO **RIGHT** SIDE OF THE BED. BOLT INTO THE HOLES MARKED (R) WITH BLUE LABELS. THE MECHANISMS ARE LABELED M (a) & M (b) PLEASE CAREFULLY FOLLOW THE DIAGRAM BELOW.

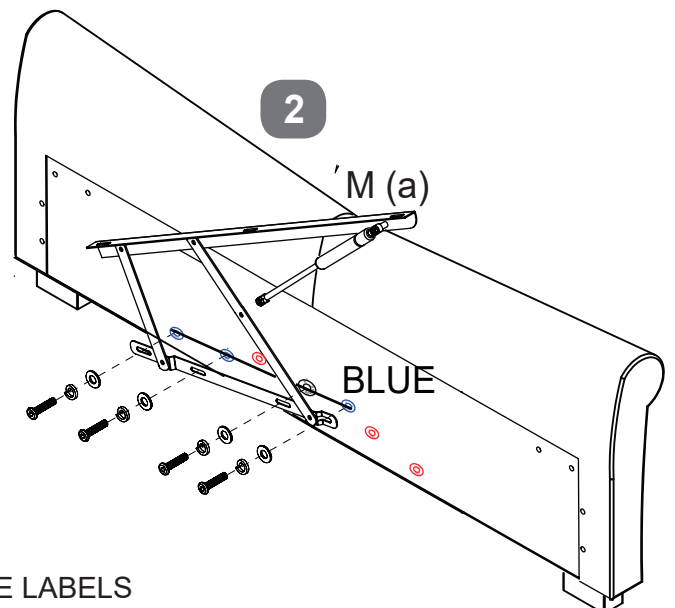
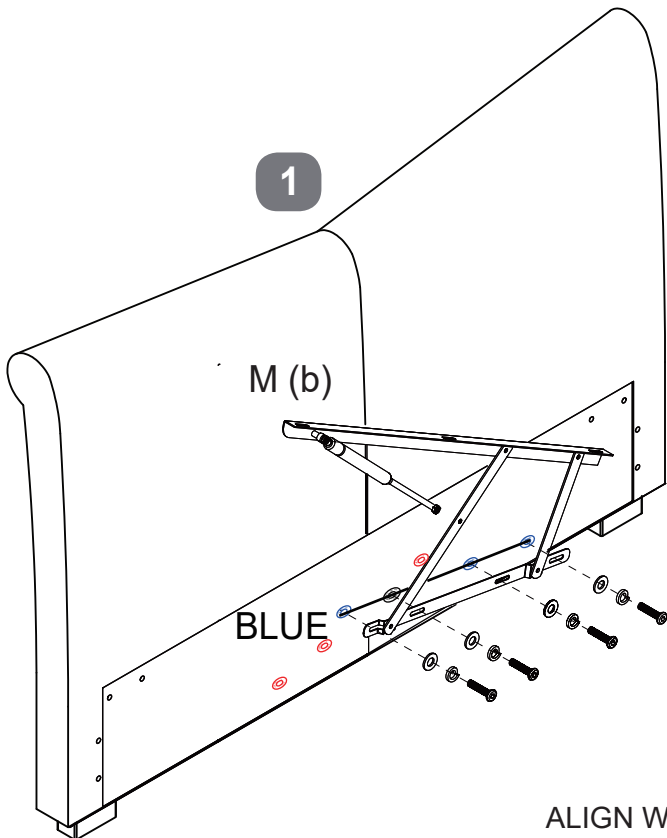
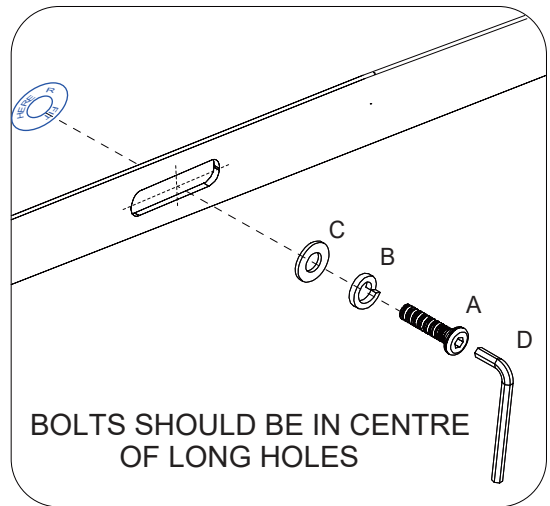

ALIGN WITH BLUE LABELS
MAKE SURE FIXING BOLTS ARE IN
THE CENTRE OF THE LONG HOLES

Fitting Gas-Lift Mechanisms- Use Pack 'A'

Stage
1b

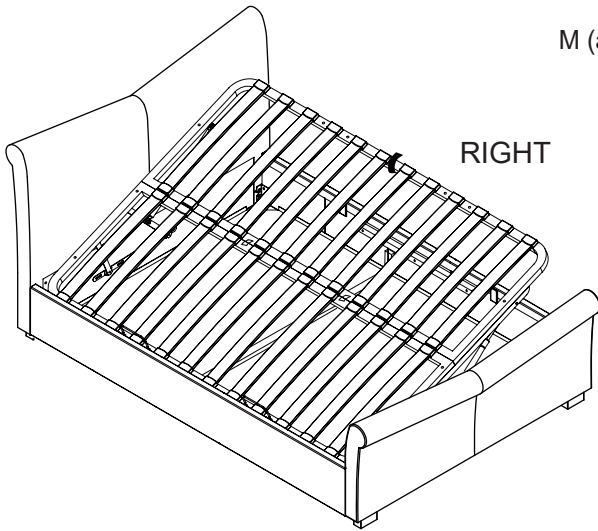
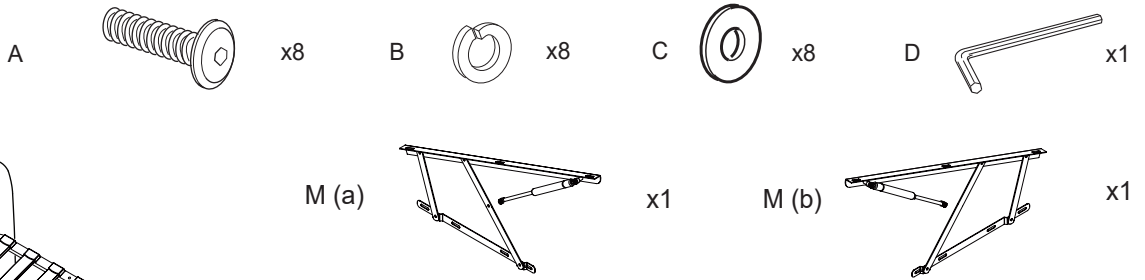

CHECK THIS DIAGRAM AND IF ACCESS IS NEEDED FROM RIGHT SIDE OF BED, FIT BOTH LIFT MECHANISMS TO **LEFT** SIDE OF THE BED. BOLT INTO THE HOLES MARKED (L) WITH RED LABELS. THE MECHANISMS ARE LABELED M (a) & M (b) PLEASE CAREFULLY FOLLOW THE DIAGRAM BELOW.

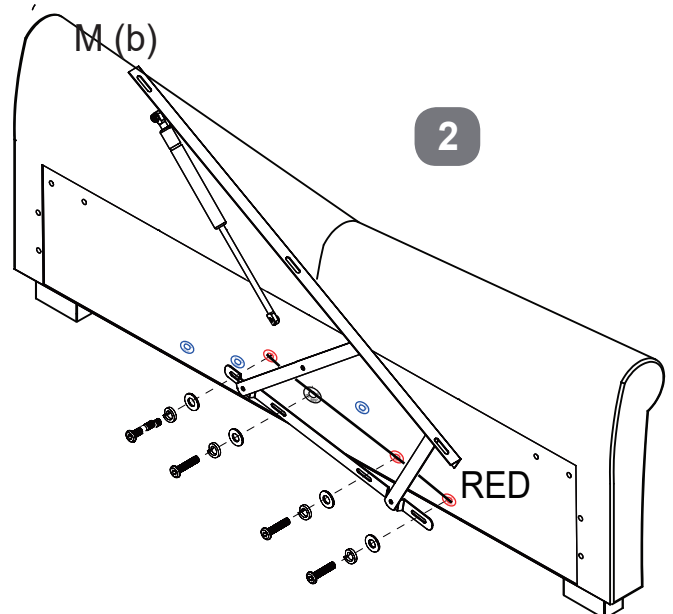
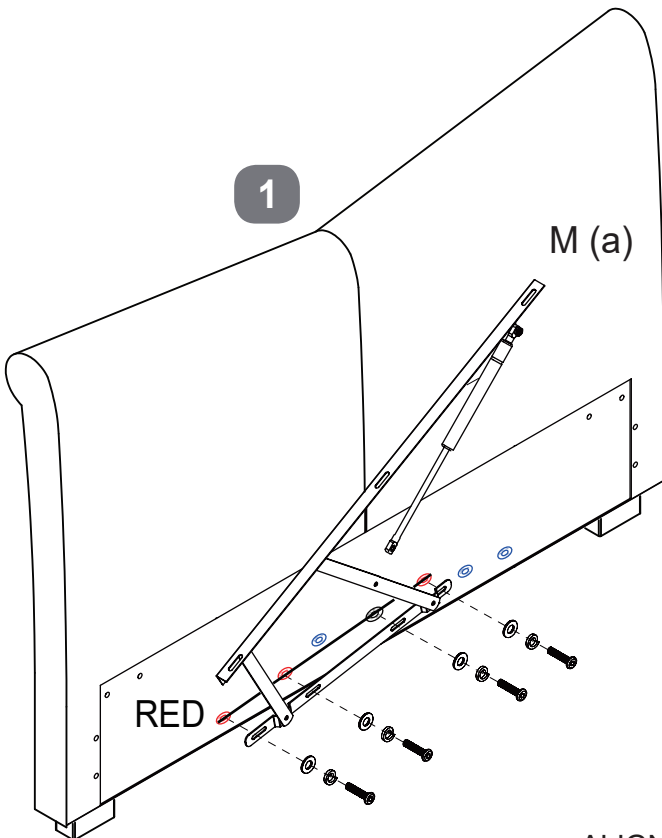
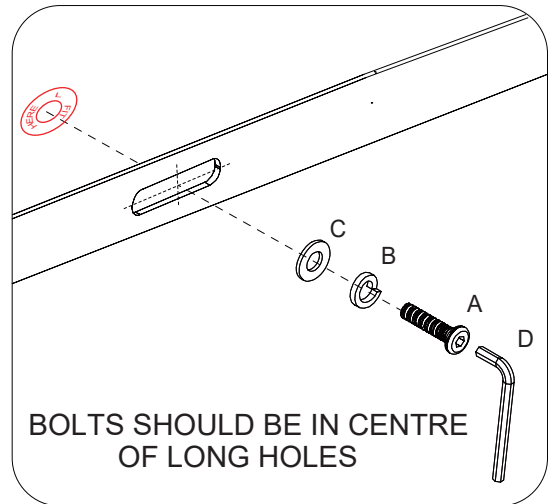

ALIGN WITH RED LABELS
MAKE SURE FIXING BOLTS ARE IN
THE CENTRE OF THE LONG HOLES

Bed Assembly - Use Pack 'B'

Stage
2



i) Loosely insert two sets of Bolts (A) with spring washers (B) & flat washers (C) into each side of Headboard & Footboard (1&2).

Note: Do not tighten fully but leave 10mm protruding as in the diagram.

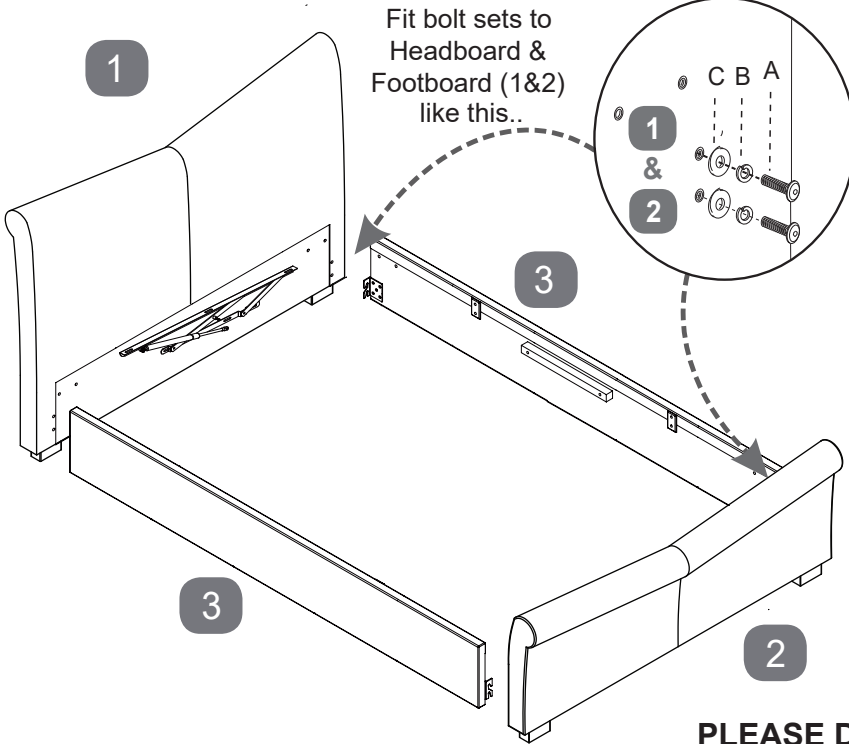
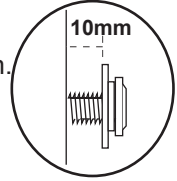

ii) Fit the side panels locating the brackets behind the flat washers.

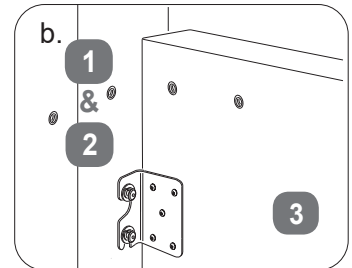
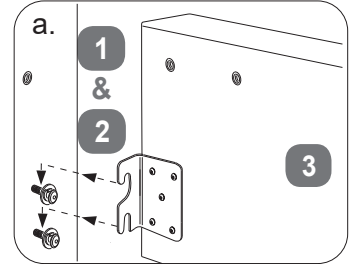

PLEASE DO NOT TIGHTEN ANY BOLTS YET.

Stage
3



iii) Square up the bed to 90 degrees - then using sets of bolts (A), spring washers (B) & flat washers (C) fit Angle Brackets (5) into threaded inserts in the corners of Headboard & Footboard (1 & 2) & Side Panels (3).

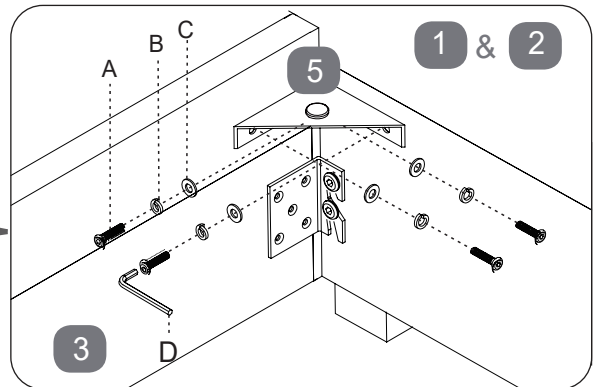

iv) MAKE CERTAIN THE BED IS SQUARED UP AS IN THE DIAGRAM.

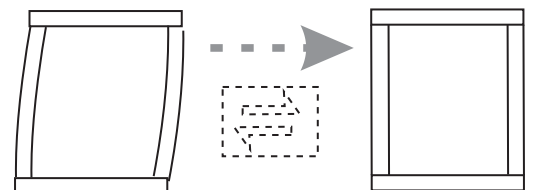

v) Fit the 'U' Shaped Cross Bar (8) to centre of each side panel (3). Line up the ends of the bar between the two marked lines & fix into the side rails using screws (K). Note the screws drive straight into the side rail itself, there are no pilot holes.

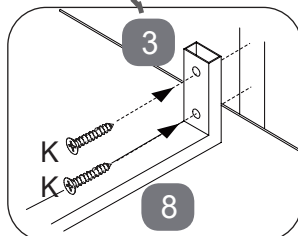

vi) Once all four corners are located tighten all the bolts using the Allen key (D).

Bed Assembly

Stage
4

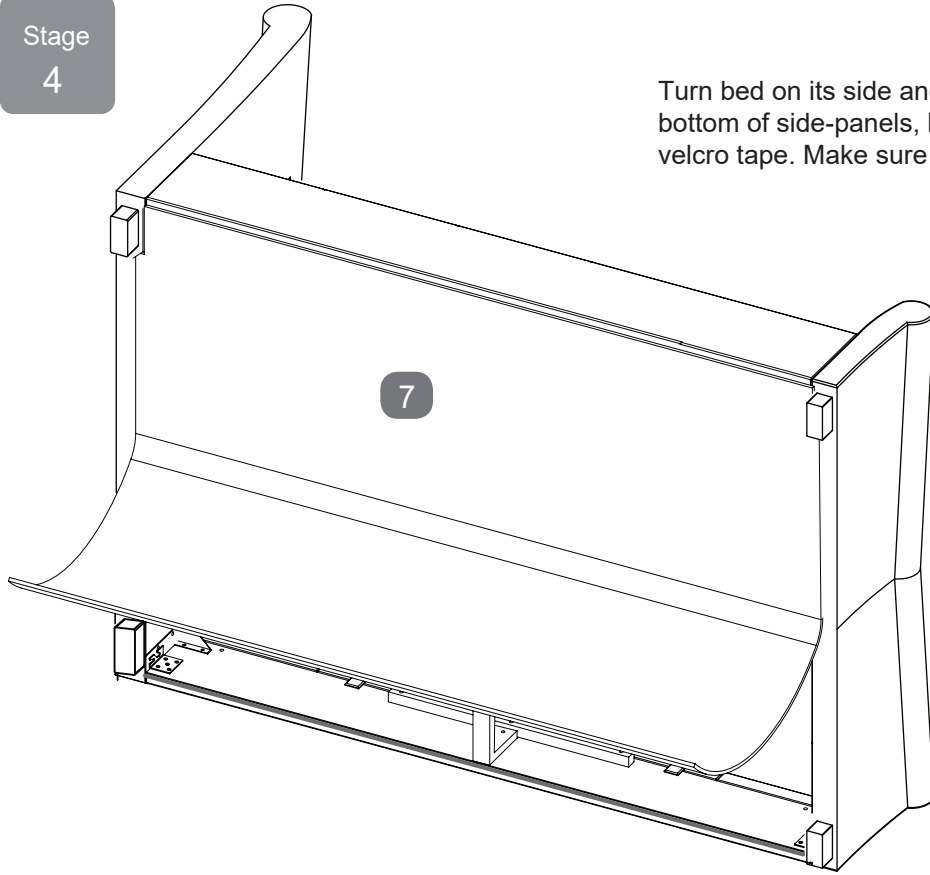

Turn bed on its side and attach Fabric Base Cover (7) to bottom of side-panels, headboard & footboard with the velcro tape. Make sure fabric is fixed evenly all round.

Fitting Slat Frame - Use Pack 'C'

Stage
5

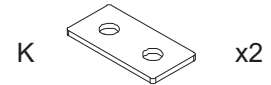
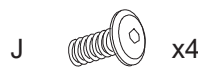
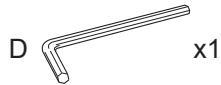

i) Open Metal Slat frame (4).

ii) Using four sets of bolts (J) & flat washers (C) fit two pieces of the metal plate (K) into threaded inserts on top of the Slat frame (4). Using Allen key (D), tighten them 100%.

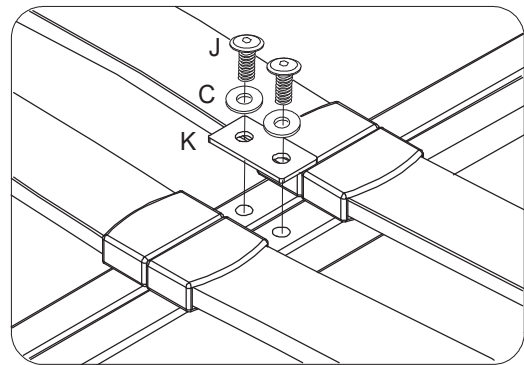
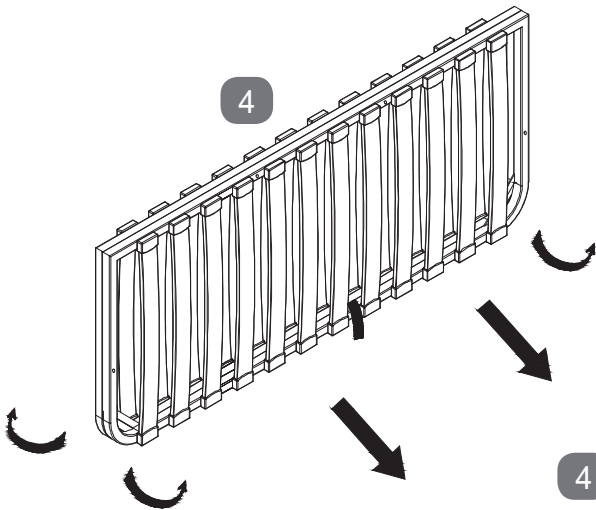

x2

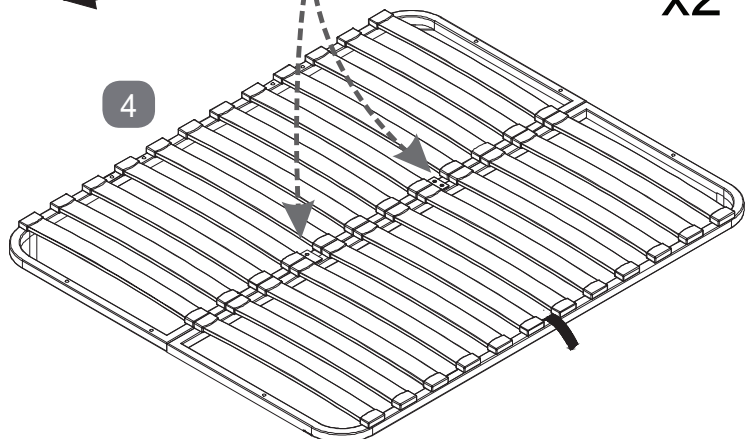

Fitting Slat Frame

Stage
6

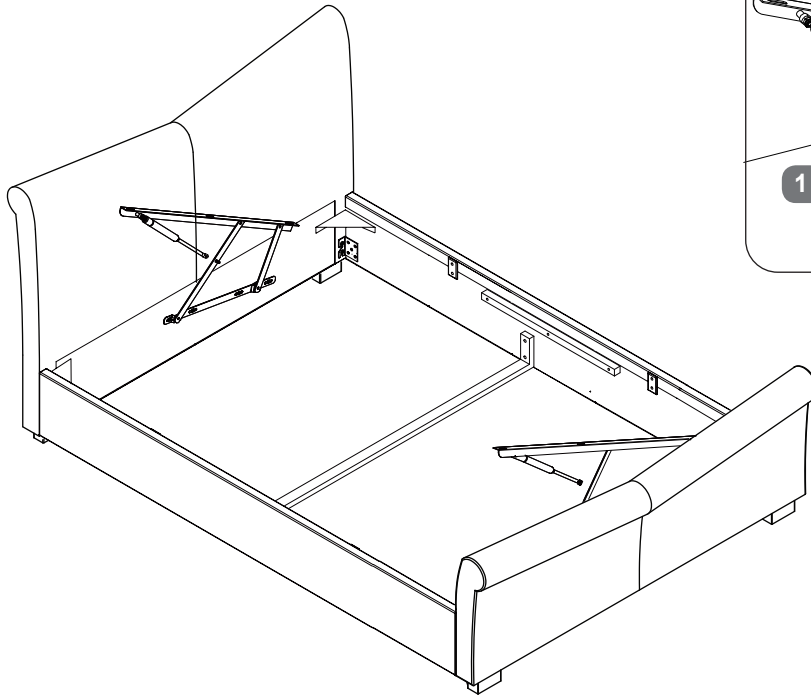

HOLD THEM FORWARD

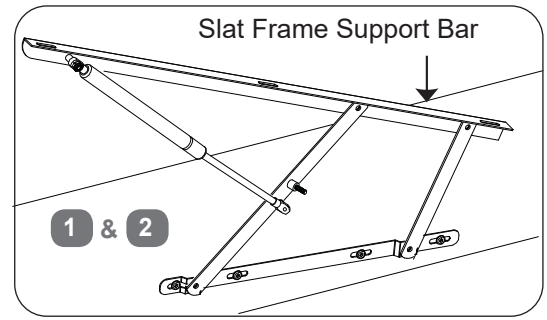

Fitting Slat Frame - Use Pack 'C'

Stage
7

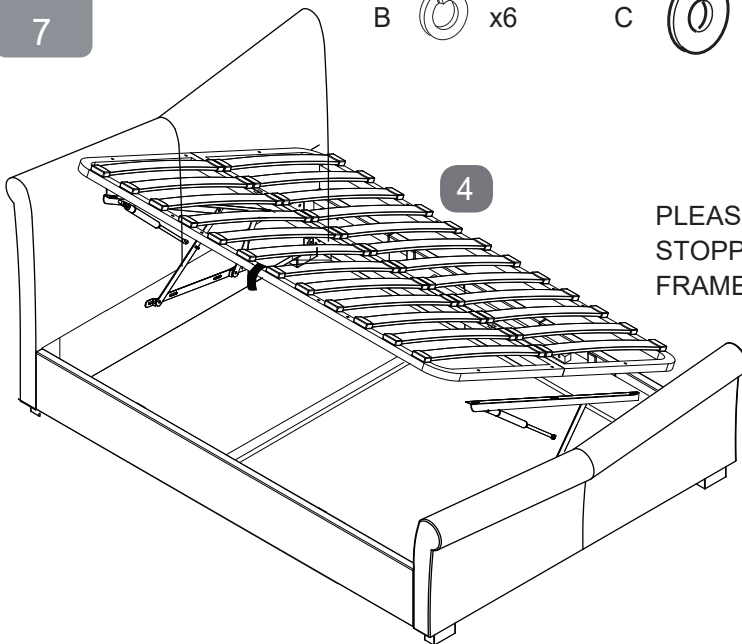
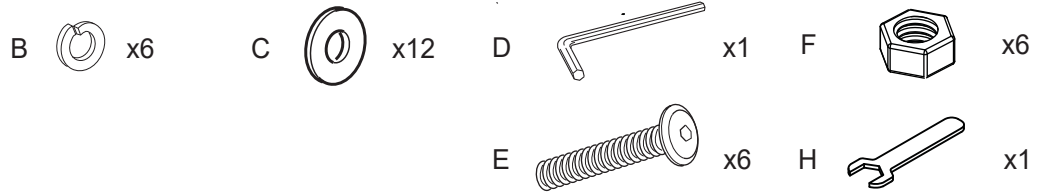

PLEASE NOTE: MAKE SURE THE HOLES FOR MATTRESS STOPPERS ARE ON THE CORRECT SIDE OF THE SLAT-FRAME BEFORE BOLTING TOGETHER.

- i) With help, lift Slat Frame (4) onto slat frame support bars.
- ii) Using two bolt sets on each side, (E), (C), (B) & (F), loosely fix slat frame to six holes - finger tight.

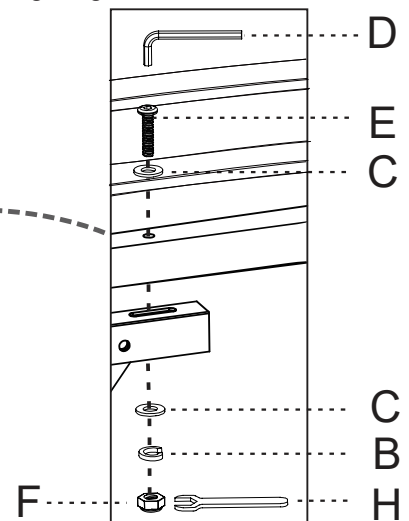
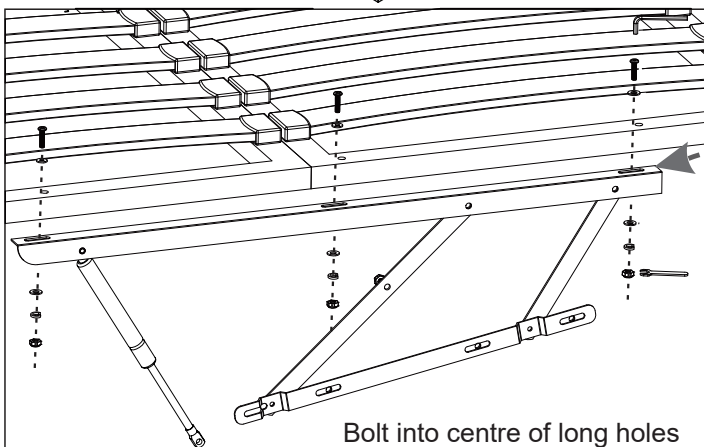

Stage
8



Carefully lay frame down. Make sure there is an even gap each side of about 10mm, as in the sketch.

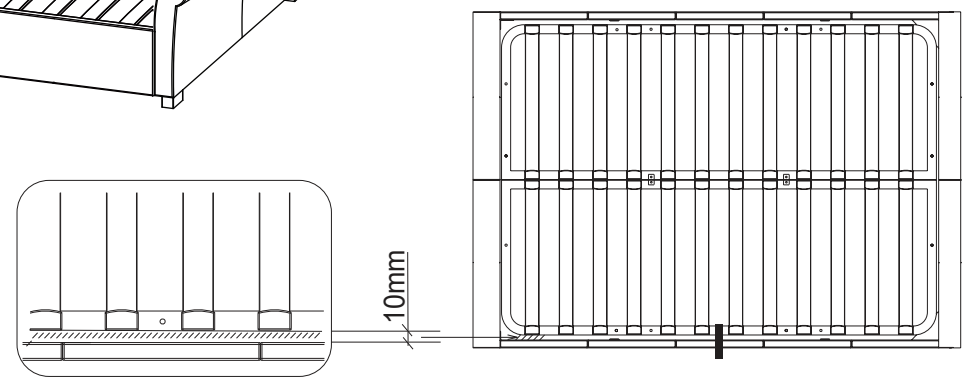
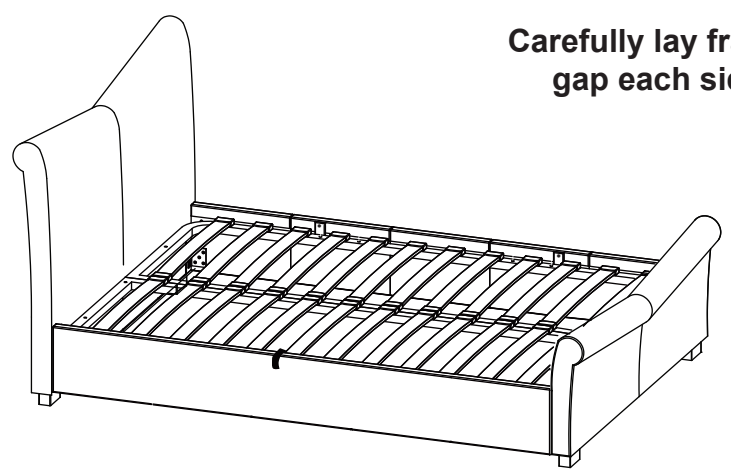

Hold frame then tighten all six bolt sets 100% using spanner (H) & Allen key (D).

Fitting Slat Frame - Use Pack 'C'

Stage
9

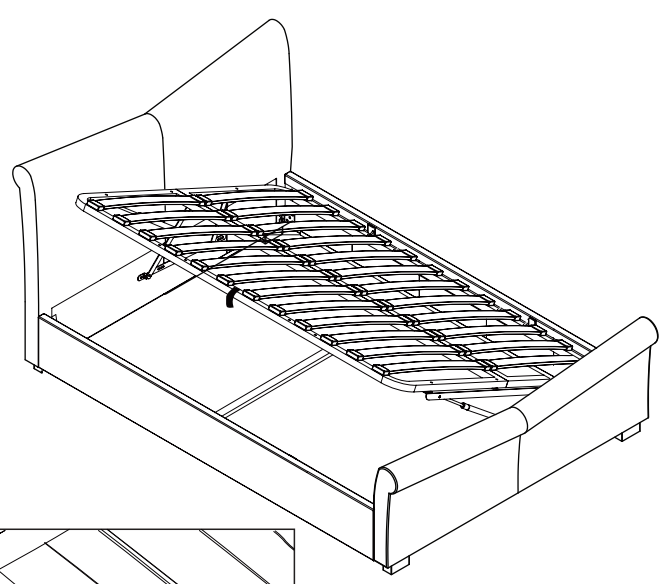
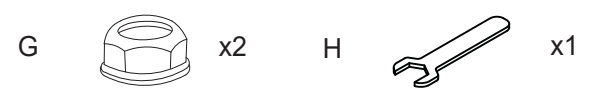

Slide gas-lift piston stem onto the axle then fit the flange lock-nut (G). Tighten nut with spanner (H) - do not over-tighten. A small gap is left so stem can move freely - this is normal - see sketch below.

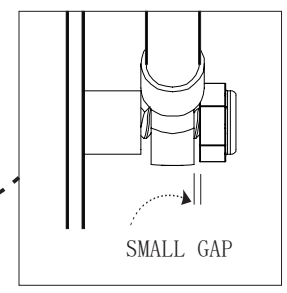
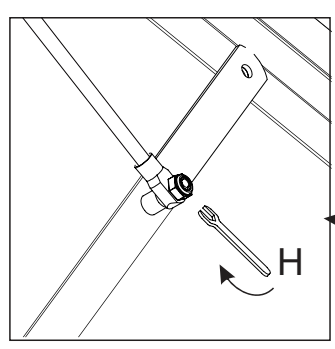
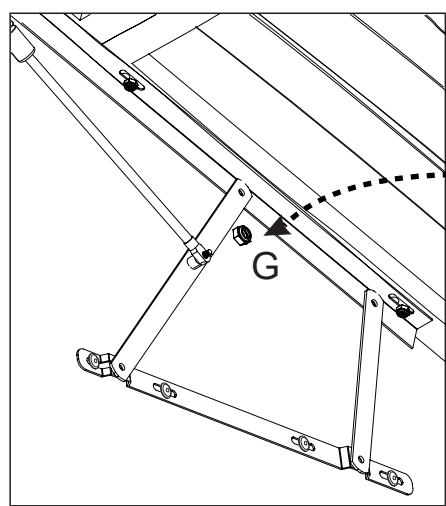

Stage
10

Push x2 Mattress Stoppers (6) into metal frame.

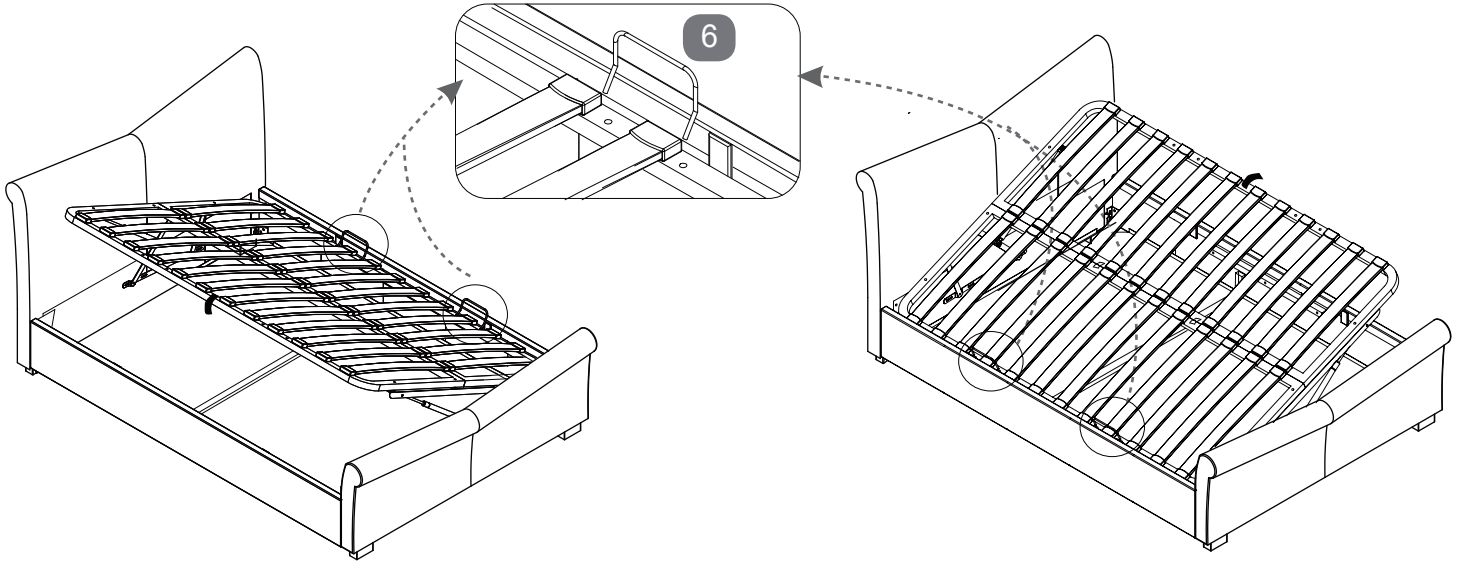

Note: Place mattress on slats then slowly push down metal frame ensuring the frame is aligned with the side panels. Depending on the weight of the mattress, the speed of the lift will vary so be careful until you get used to the speed.

Always use the fabric handle to lift or lower the frame - keep fingers well away from the moving parts.

Overall Dimensions

DOUBLE: W145cm X L222cm X H108/57cm

