

Tribeca Ottoman Bed

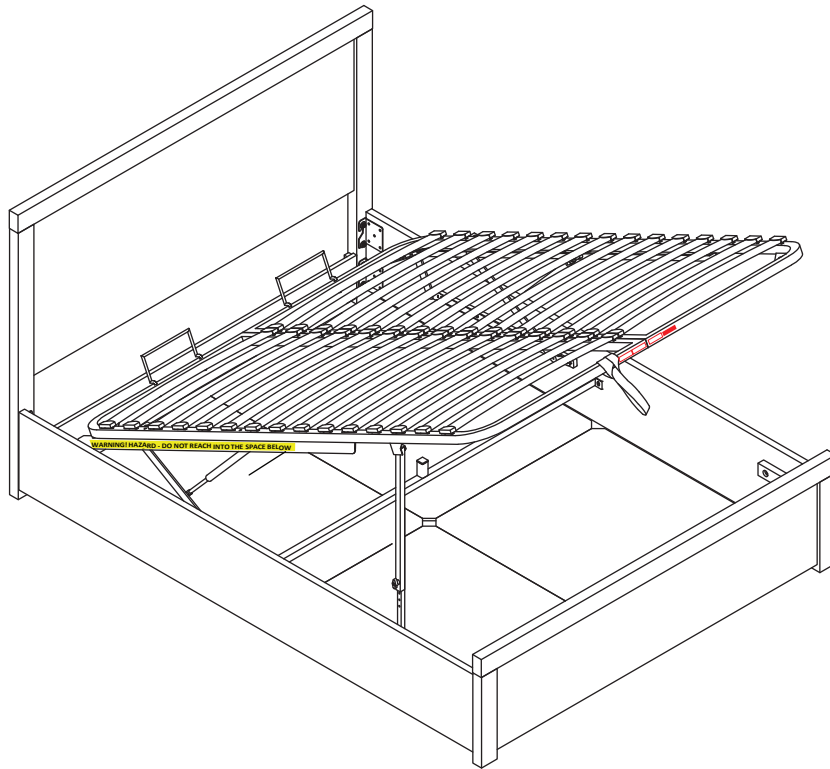

IMPORTANT OTTOMAN SAFETY WARNINGS

- **IMPORTANT - READ CAREFULLY - RETAIN FOR FUTURE REFERENCE**
- **You must ensure that the mattress is on the bed frame before operating the lift mechanism - Failure to do so could result in injury.**
- **Keep hands clear of the mechanism when opening or closing the ottoman.**
- **Beware of entrapment - Never reach in through the mechanism to access the storage area.**
- **Always ensure that the ottoman is FULLY opened before accessing the storage area.**
- **Do not exceed the maximum weight as specified in the table below:**

Bed	Bed Size	Min Weight (kg)	Max Weight (kg)
Tribeca	Small Double	20	45
	Double	20	50
	King	20	50



1.5 hour approx
assembly time



Two person
assembly

Dreams

IMPORTANT OTTOMAN SAFETY WARNINGS Cont.



- Use caution when operating, always use the handle when lifting.
- Note: This bed uses a pressurised mechanism.
- To be operated by adults only.
- Please ensure that children and pets are kept away from the bed when operating the lift mechanism.
- Keep children and pets away from the storage area.
- Do not overload the internal storage base.
- Do not stand inside the internal storage area of the bed.
- Before removing the mattress secure the frame to ensure it does not open unexpectedly.
- Do not attempt to lie on the mattress when the ottoman is in the raised position.
- When lifting the ottoman, remove all bedding except the fitted sheet.

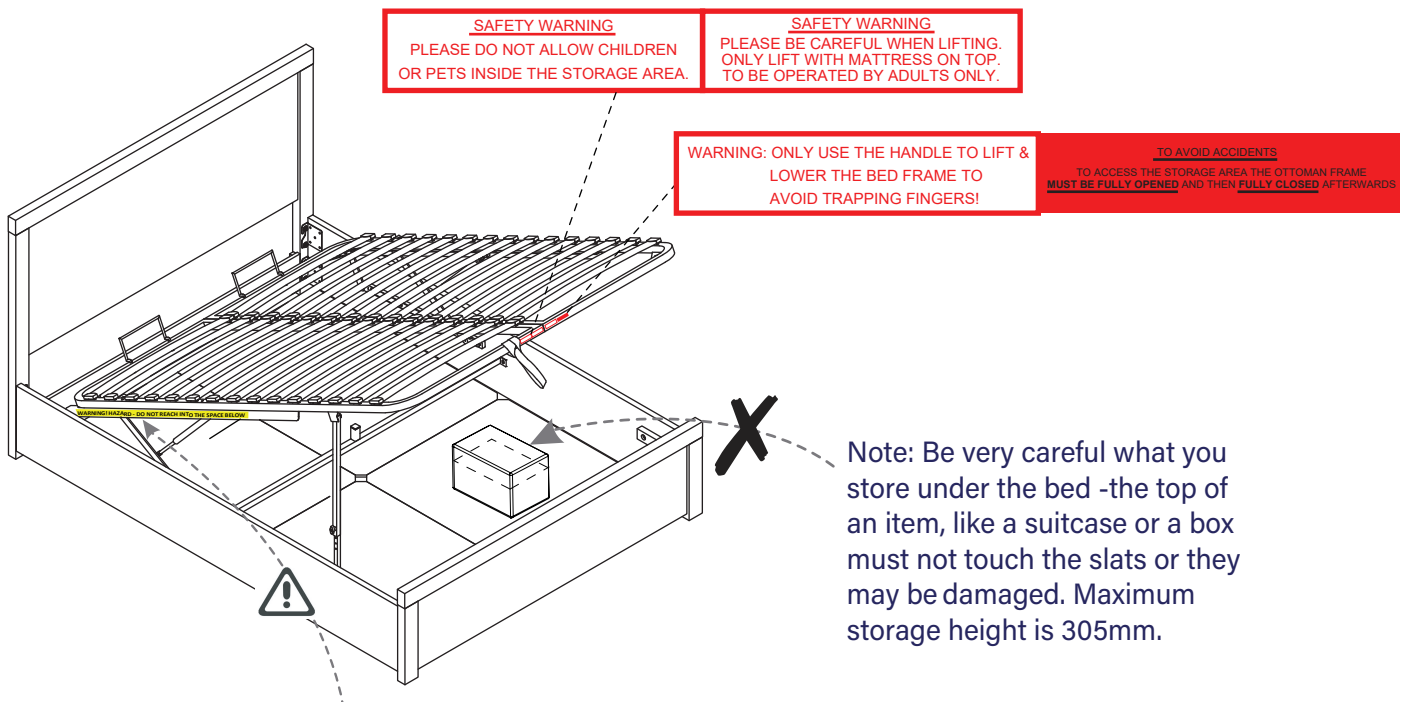

! WARNING! HAZARD - DO NOT REACH INTO THE SPACE BELOW!

Ottoman Beds - Important Safety Features

Our aim is always to give you the best experience and to ensure every effort has been made to guarantee your comfort and safety. Please take time to look at these instructions as they will help remind you how to operate your ottoman bed safely.

Here's a few things you need to remember;

- ✓ **Pistons are already assembled in their correct orientation - this improves piston performance and durability.**
- ✓ **"Break in" the piston seals on first use by raising & lowering the platform at least five times.**
- ✓ **Recommended mattress weights - do not exceed the maximum relevant weight specified on the Assembly Instruction.**
- ✓ **Ottoman support bar - always engage the support bar when accessing the ottoman storage area.**

Read all the instructions before using your Ottoman bed-frame and save the instruction booklet for future reference.

Ottoman Support Bar (O.S.B.)

For optimal safety during operation, always ensure the O.S.B. is engaged when accessing the ottoman storage area.

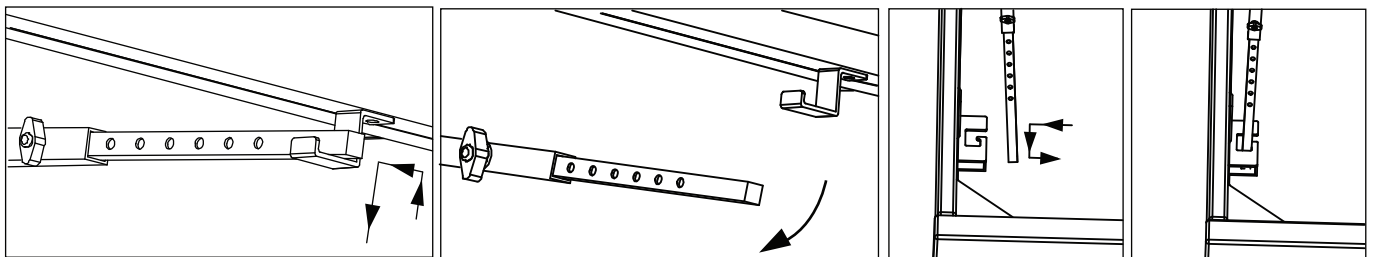

1. Always raise the ottoman slat-frame to its highest position before using the storage area.
Locate the end of the O.S.B and insert into the fixed retaining bracket on the bed frame.
2. When you are ready to lower the ottoman platform, return the O.S.B to its original parking position.
3. Always ensure that the O.S.B is in position when the ottoman is open, this prevents injury, or damage to the product.

Location of the O.S.B

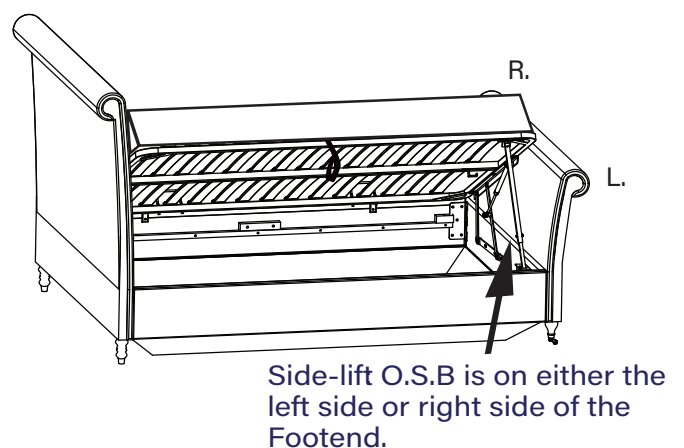
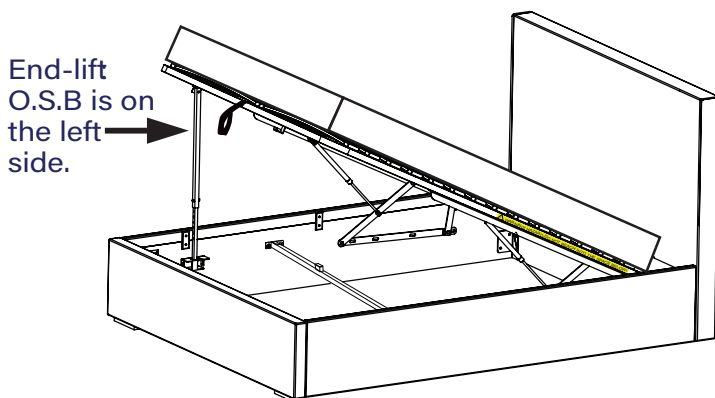

WARNING! Risk of Entrapment

- The pistons on the ottoman bed frame can support a maximum load (evenly spread) as indicated in the Minimum and Maximum load table, in the main Assembly Instruction.
- Overloading the sleeping platform may contribute to damage to the product resulting in potential serious injury.
- Do not sit on the mattress whilst the platform is in motion or is in the raised position.
- Users should only get in and out of bed when platform is in the flat (horizontal) position.

Thank you

Hello, thanks for choosing to purchase your bed from Dreams - you're now on your way to your best ever night's sleep. Before you begin building your bed, please take a moment to read through the instructions and make sure that you've got all the relevant parts listed on the following pages.



Assembly tips

Before you begin, it's best to identify all parts and fittings to build your bed. We advise laying these out on the floor to check you have everything, and familiarising yourself before building.



Top tip

We recommend that you build your new bed in the room you'd like it to be located - this will help prevent any risk of damage to your newly built bed whilst moving it.



Safety and care

It's really important to ensure children and animals are kept away from the assembly area, as there are small components used in this bed which could present a choking hazard. All plastic and wrapping materials should also be kept away from children and animals to prevent any risk of suffocation. To keep your little ones busy, there is a colouring page inside the back cover.



Help and support

At Dreams, it's our mission to give the whole nation a great night's sleep - this means that the quality of our products is of utmost importance to us. If there are any issues with your product or any missing parts, please contact our Help Centre on 0800 652 6750, where a member of our team will be happy to help. (For customers based in Northern Ireland, please call 028 9050 8300)



Recycling

Please ensure that packaging is disposed of in a safe and environmentally friendly way, and recycle where possible. Our assembly instructions are printed on recycled paper. Please keep your assembly instructions safe to refer back to in the future.

Parts

Important information

The bed you have purchased comes with two different base options, Ottoman lift-up or Sleepmotion base. Identify which base you have purchased as the assembly method may change.

If you have purchased the Ottoman base please follow the instructions below in the current order.

If you have purchased the electric bed base, please ignore these instructions and follow the assembly instructions provided in the Sleepmotion side rail pack 3L.

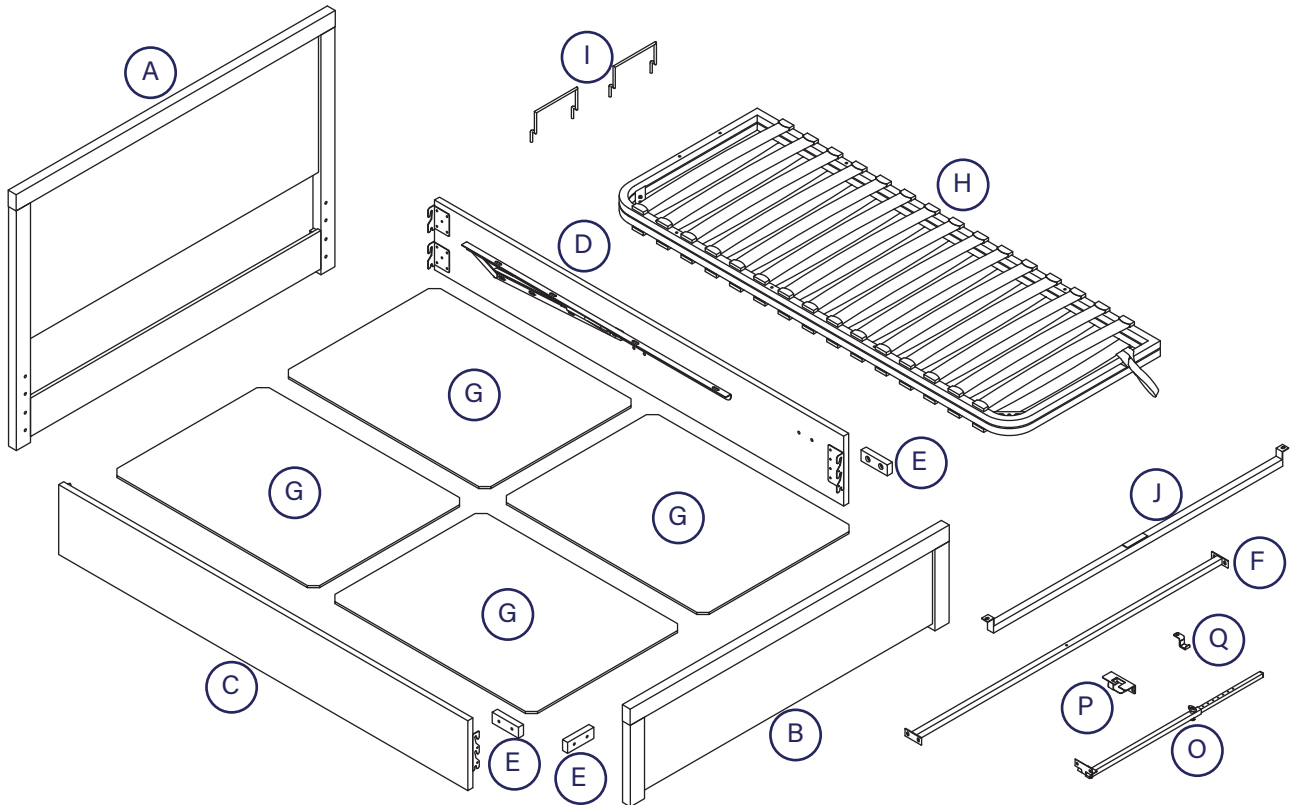

Parts list



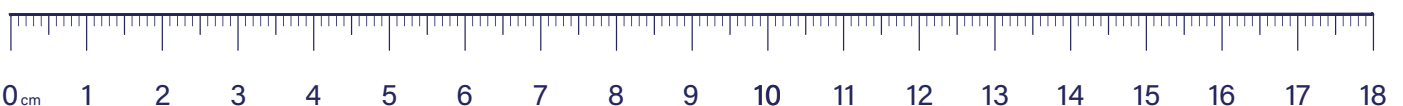

Code	Description	Qty	Box	Code	Description	Qty	Box
A.	Headboard	1	1	H.	Metal lift up slat frame	2	3
B.	Footboard	1	3	I.	Mattress stopper	2	3
C.	Side rail - left	1	2	J.	Slat frame cross bar	1	3
D.	Side rail - right	1	2		Ottoman support bar PACK (O.S.B.)		
E.	Slat frame support block	3	1	O.	Ottoman support bar	1	2
F.	Side rail cross bar	1	3	P.	Fixed retaining bracket - side rail	1	2
G.	Storage base board	4	3	Q.	Parking bracket - slat-frame	1	2





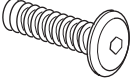



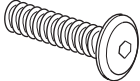

Fittings

Please check you have all the parts listed below with your product:

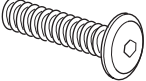

Hardware needed for fixing side rails to headboard & footboard Packed in side rail pack 2 - hardware pack (A)

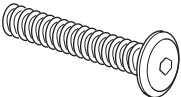
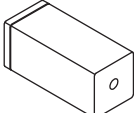
<p>a x14</p>  <p>Bolts (M8x25mm) for fitting side rails (C&D) to headboard & footboard (A&B)</p>	<p>b x14</p>  <p>Spring washer for M8 bolts</p>	<p>c x14</p>  <p>Flat washer for M8 bolts</p>	<p>d x1</p>  <p>Allen Key for M8 bolts</p>
---	--	--	---

Hardware needed for fitting metal slat frame, Packed in side rail pack 2 - hardware pack (B)

<p>a x10</p>  <p>Bolts (M8x25mm) for fitting angle brackets (F) to side rails (C&D) & footboard (B)</p>	<p>b x22</p>  <p>Spring washer for M8 bolts</p>	<p>c x29</p>  <p>Flat washer for M8 bolts</p>	<p>e x6</p>  <p>Nut for M8 bolts</p>	<p>i x7</p>  <p>Bolts (M8x35mm) for fitting support block (E) to side rail (C&D) and footboard</p>
<p>j x2</p>  <p>Metal Connection Plates</p>	<p>k x2</p>  <p>Flanged lock-nuts (M8) for gas-lift pistons</p>	<p>l x6</p>  <p>Bolts (M8x50mm) for fitting metal slat frame (H) to gas-lift mechanisms</p>	<p>p x1</p>  <p>Support block for side rail cross bar (N).</p>	<p>h x1</p>  <p>Spanner for M8 nuts</p>

Hardware needed for fixing ottoman support bar (O.S.B) to the side rail packed inside the Ottoman Support Bar carton, inside Pack 2 - hardware pack (C)

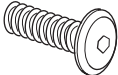
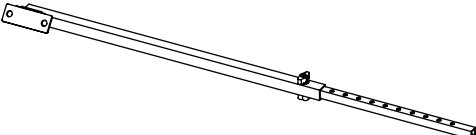
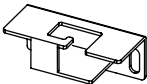
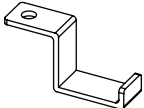
<p>b x5</p>  <p>Spring washers for M8 bolts</p>	<p>c x5</p>  <p>Flat washers for M8 bolts</p>	<p>m x5</p>  <p>Bolts (M8x25mm) for fitting ottoman stay system</p>	<p>O x1</p>  <p>Ottoman support bar</p>
<p>P x1</p>  <p>Fixed retaining bracket - side rail</p>	<p>Q x1</p>  <p>Parking bracket - slat frame</p>		

Tools required



Tape measure



Cross head screwdriver

1 Bed assembly - use pack 'A'

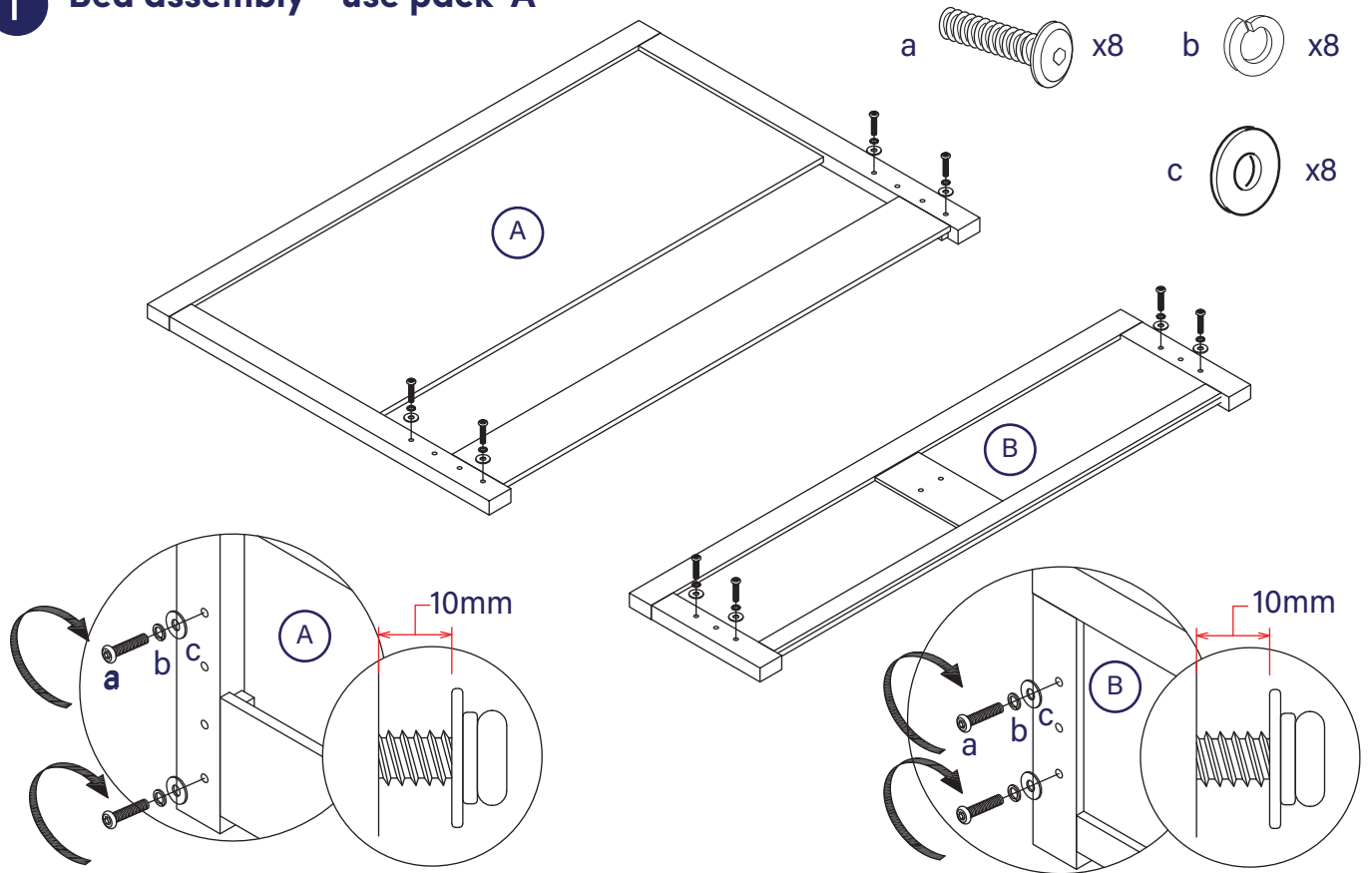

2

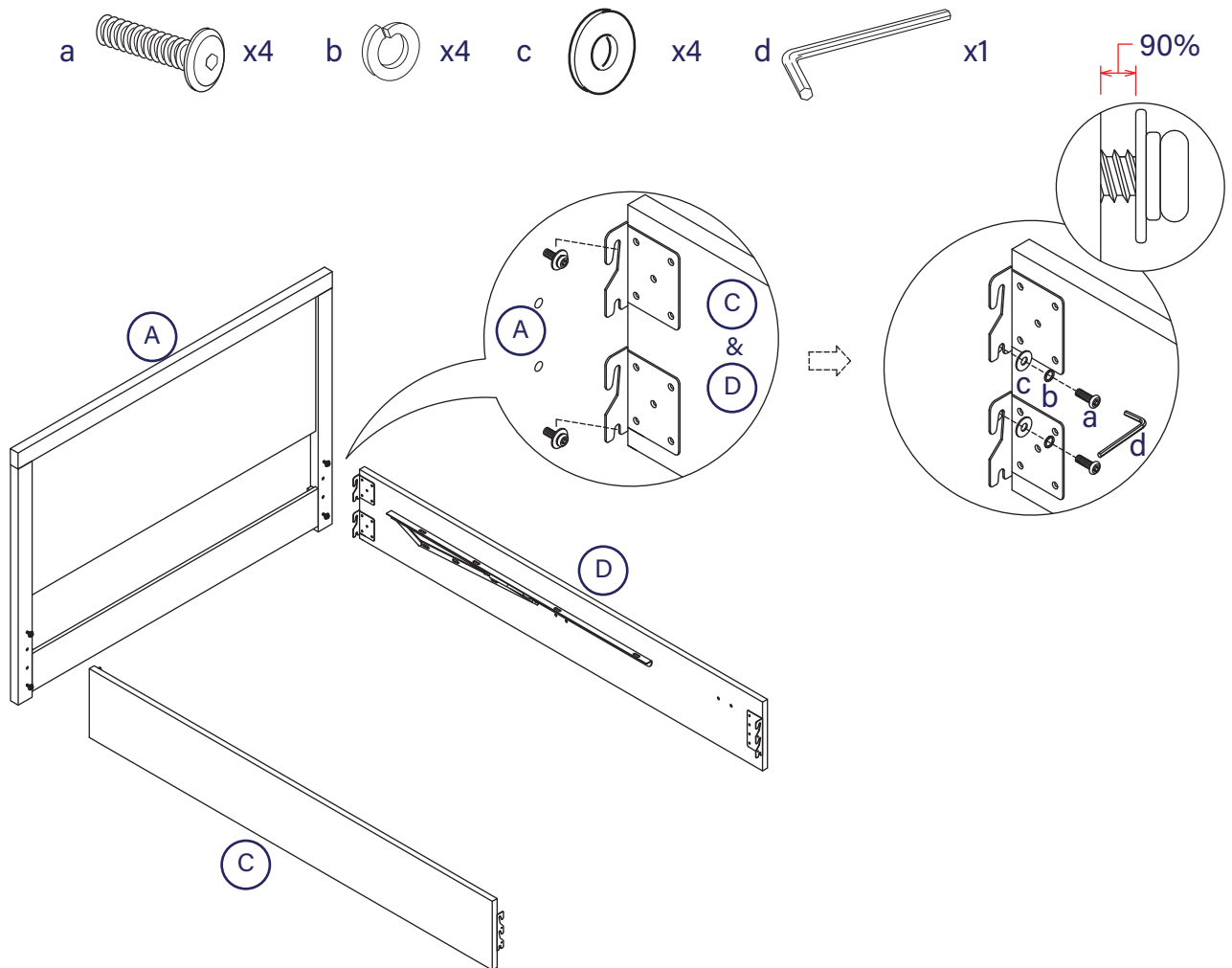

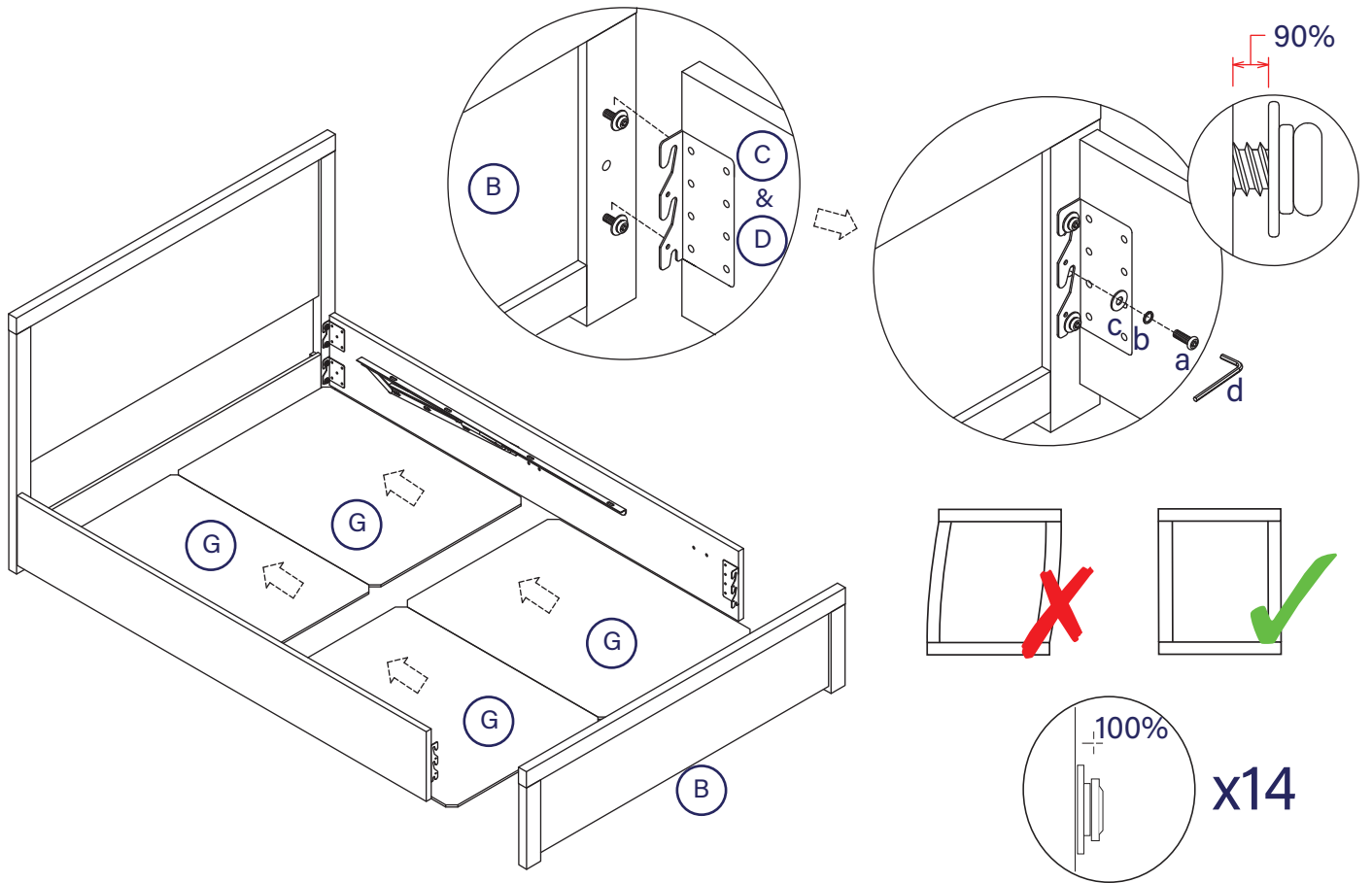

3

- a  x2
- b  x2
- c  x2
- d  x1

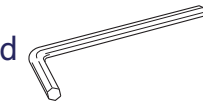
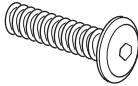

4

- b  x6
- c  x6
- d  x1
- i  x6

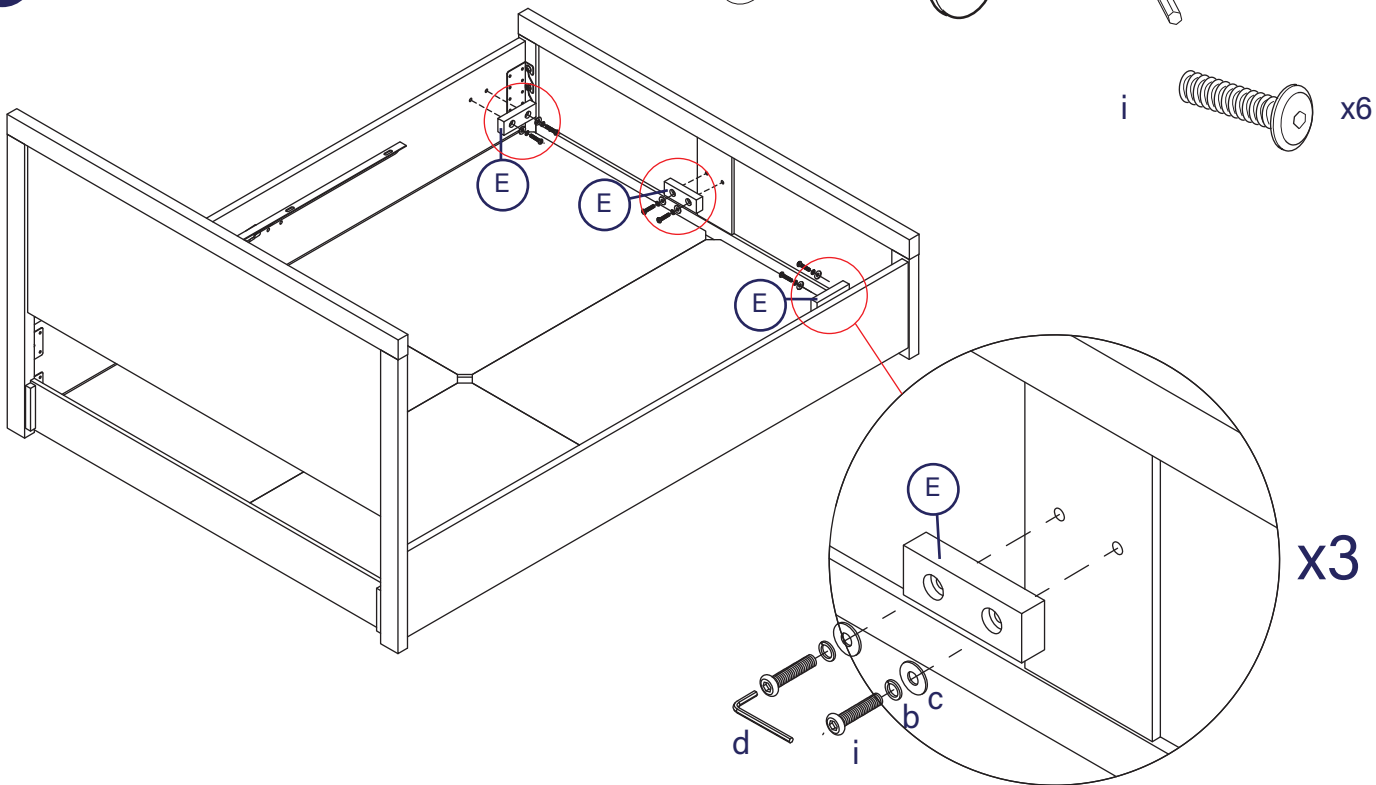

5

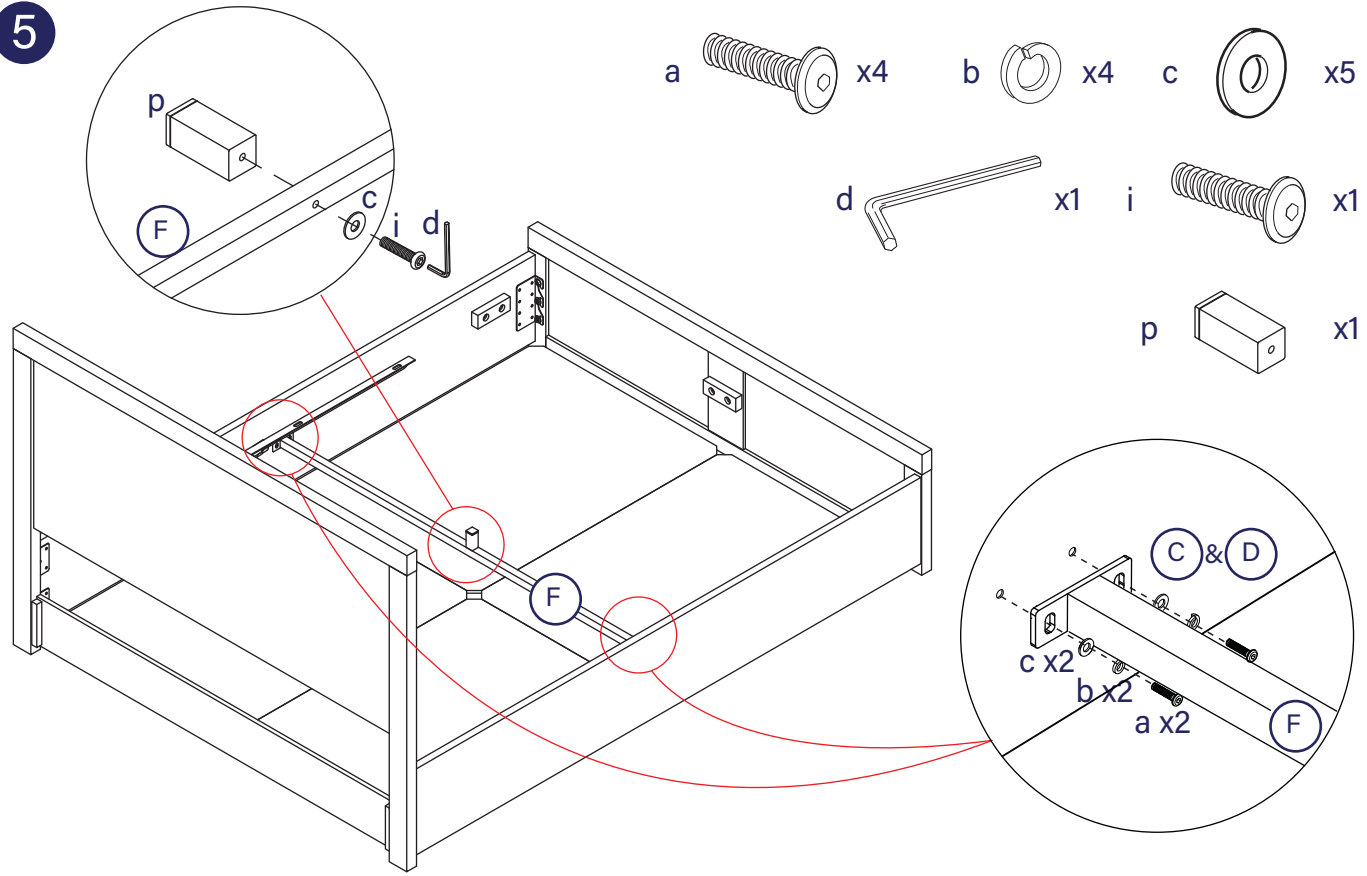



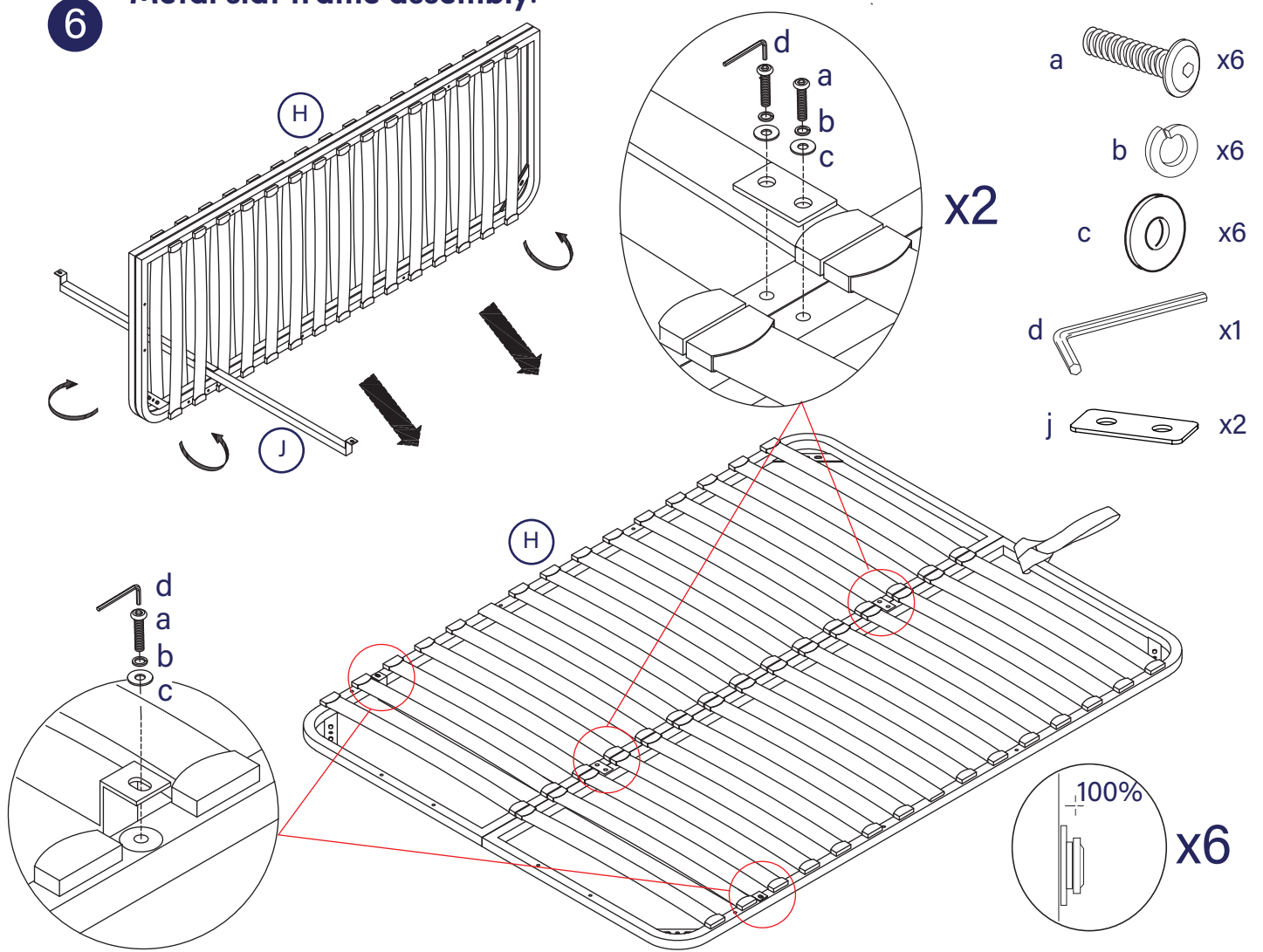

6 Metal slat frame assembly.

6

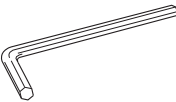

7

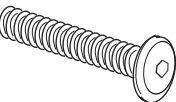
- b  x6
- c  x12
- d  x1
- e  x6
- h  x1
- l  x6

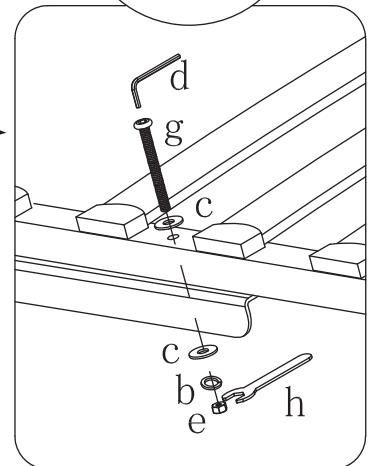
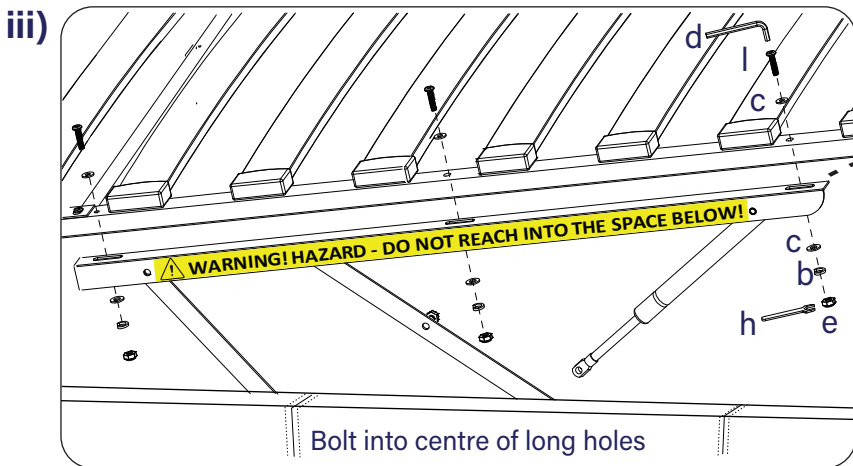
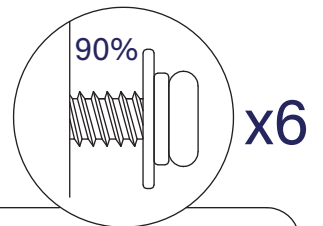
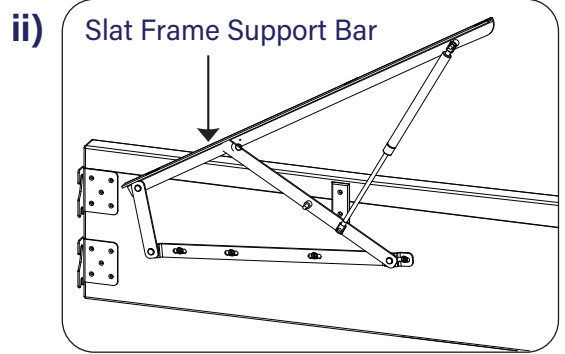
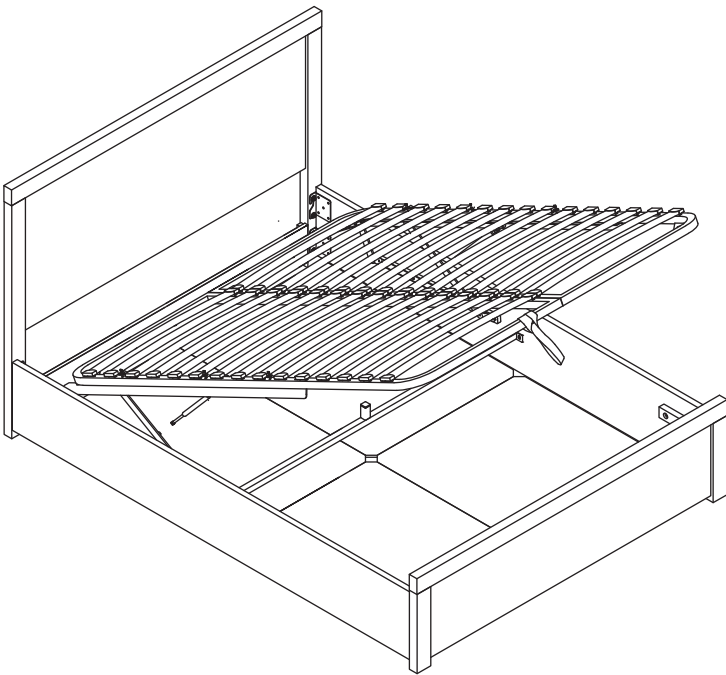
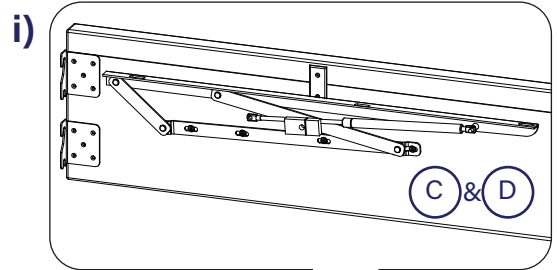
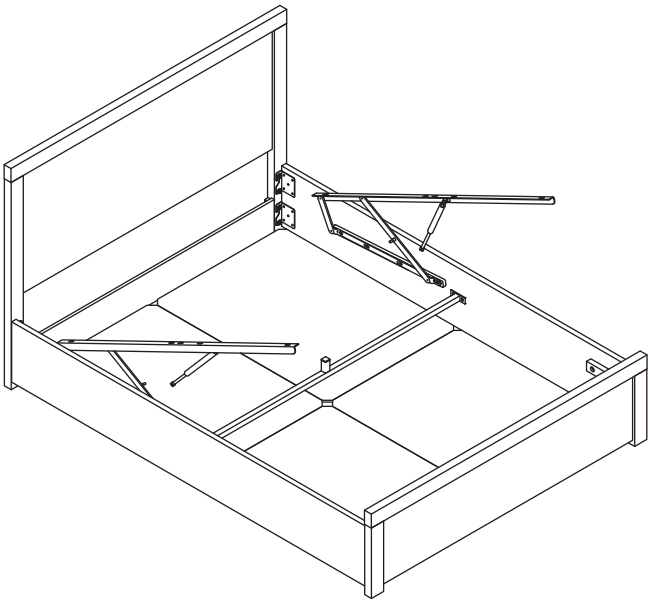

8

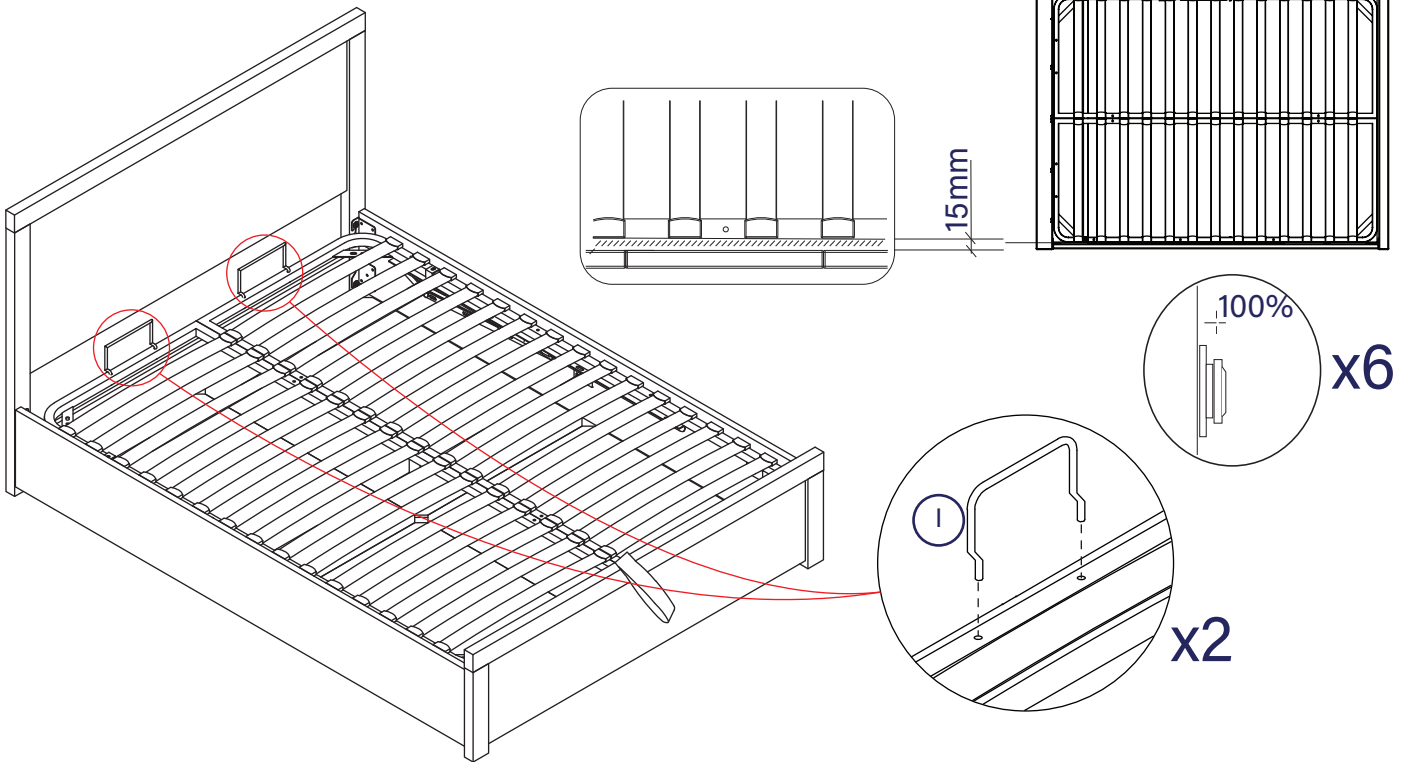

9

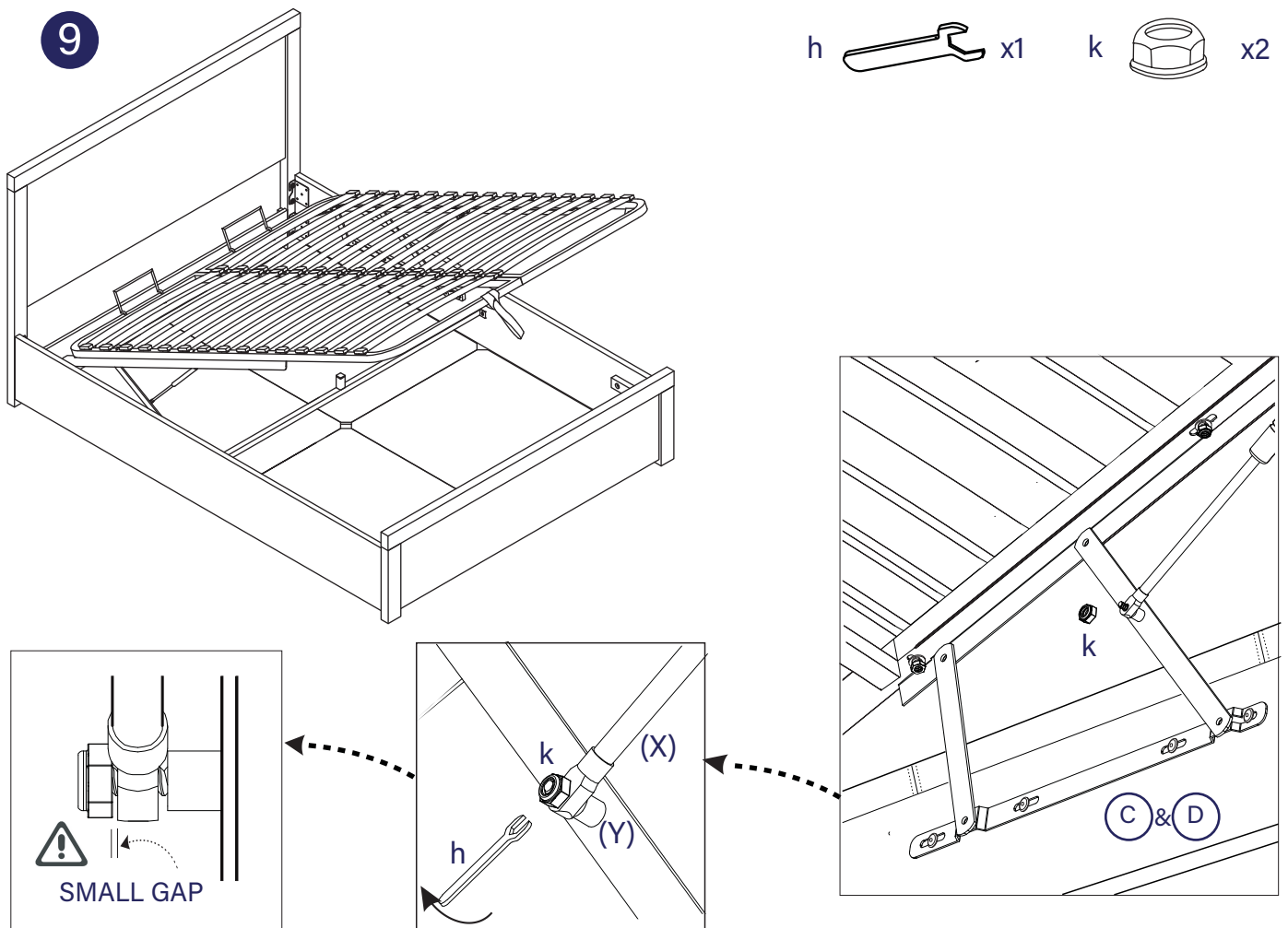

13 Unpack the contents of the Ottoman Support Bar (O.S.B.) from its carton - this is packed inside Pack 2.

b  x5

c  x5

d  x1

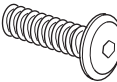
m  x5

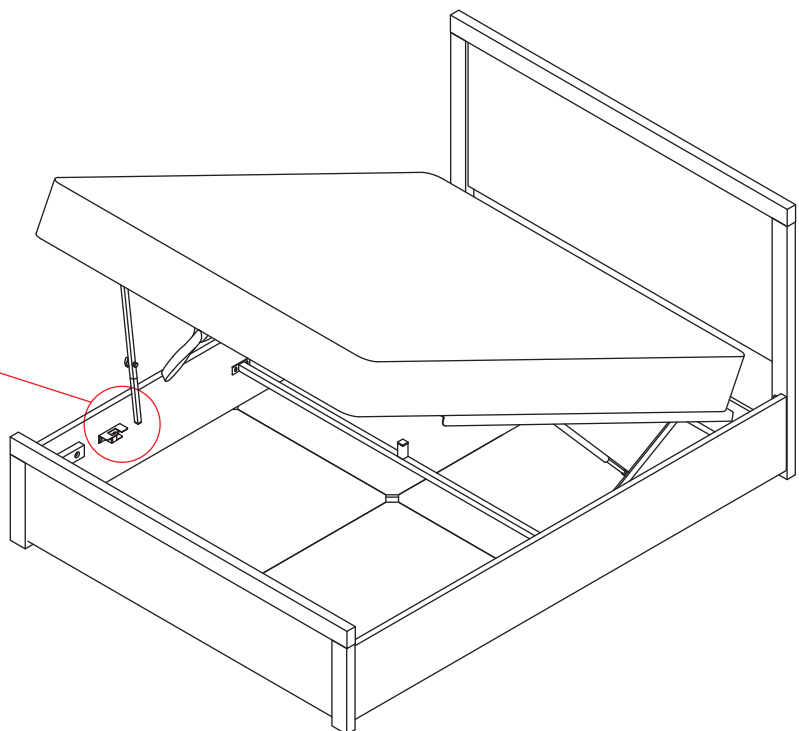
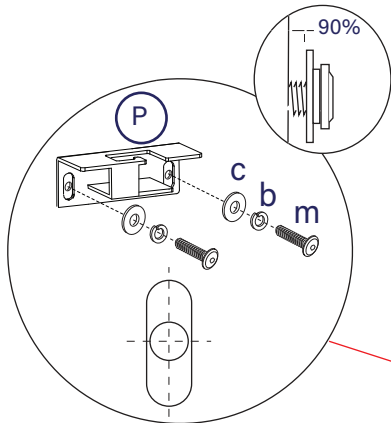
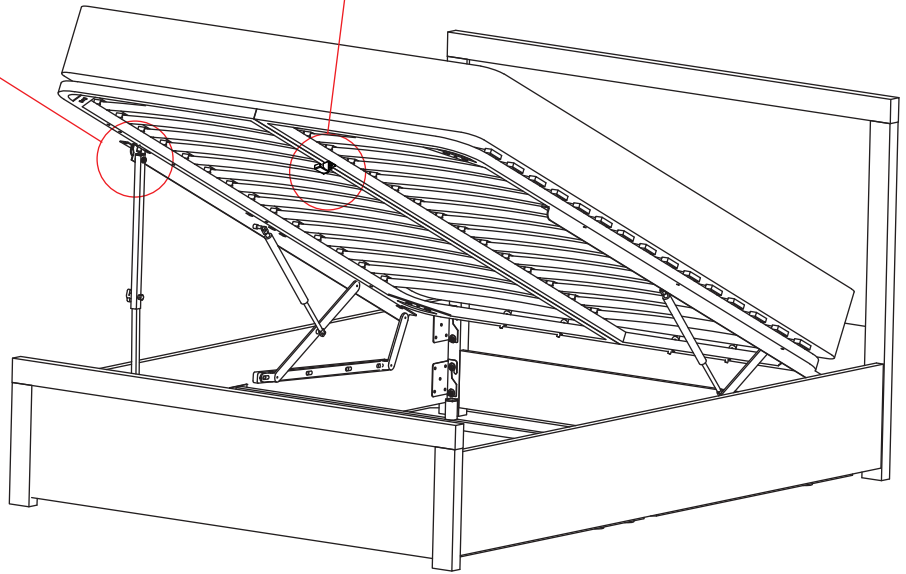
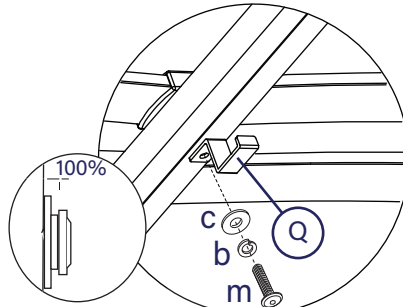
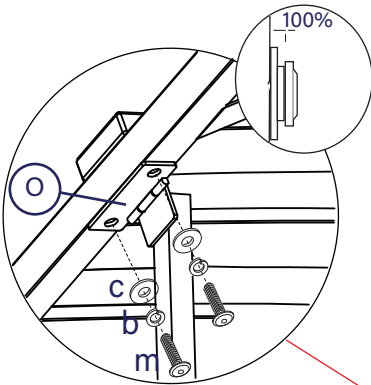

14

Setting the inner stem of the support bar (O), adjust the inner stem to the correct length.

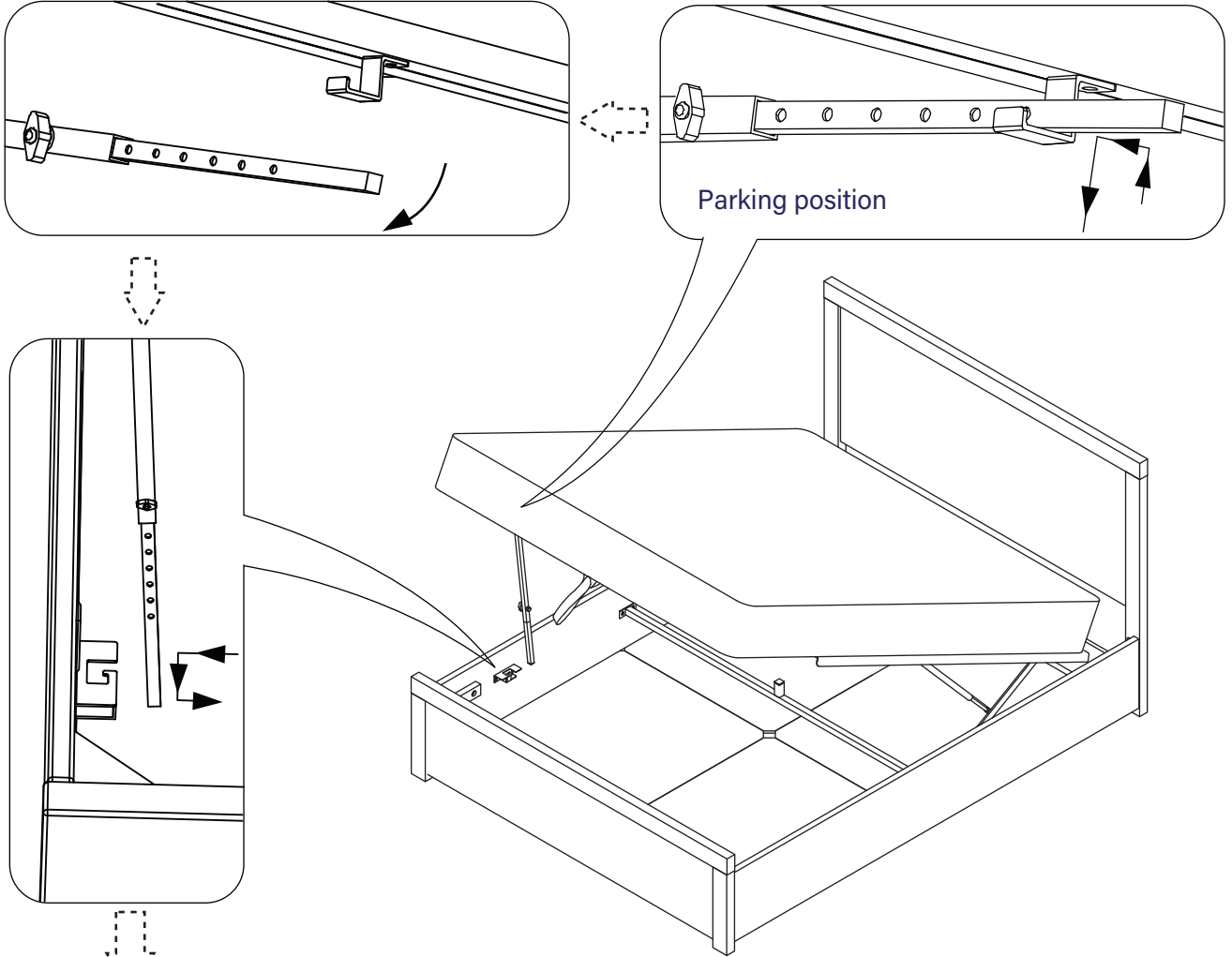

Set the inner stem to the correct length so the end just touches the retaining bracket - it needs to touch to hold it in position.

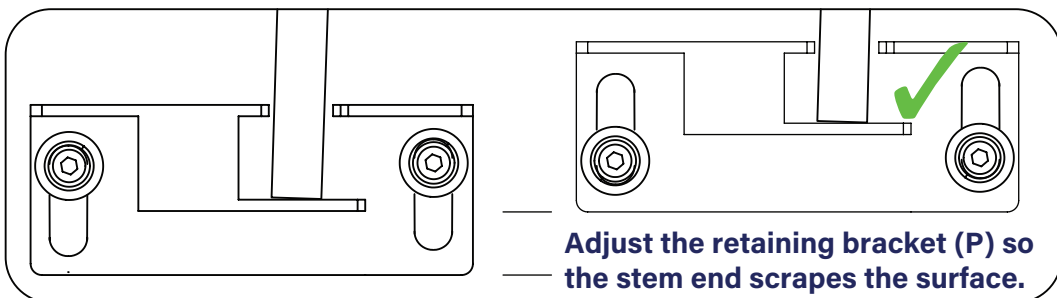
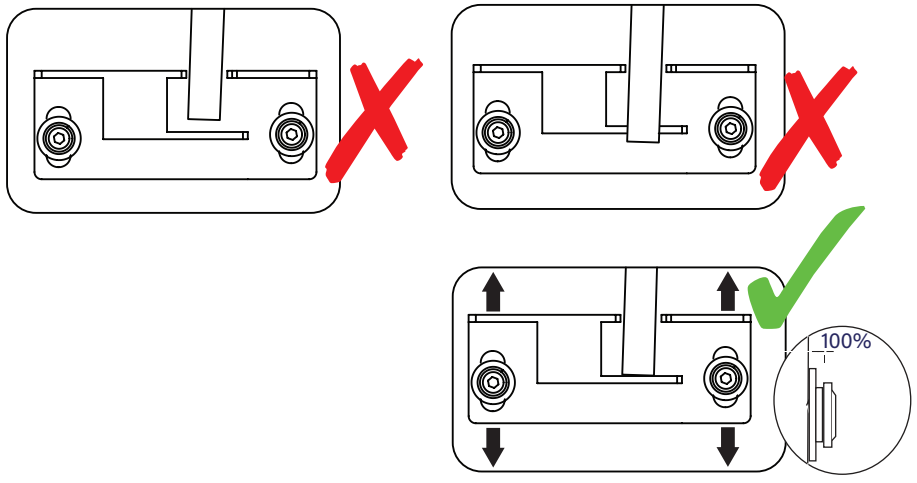

TECHNICAL SPECIFICATIONS

Overall Dimensions (LWH cm)

Small Double: 201 x 128.3 x 110

Double: 201 x 143.3 x 110

King: 211 x 158.3 x 110

Internal Dimensions (LWH cm)

Small Double: 193 x 122.5 x 21.5

Double: 193 x 137.5 x 21.5

King: 203 x 152.5 x 21.5

Distance between slats (cm)

Small Double & Double: 7

King: 6.8

Ottoman Piston Rating

Small Double: 800n

Double & King: 900n

Slat Dimensions (LWH cm)

Small Double: 59.4 x 5.3 x 0.9

Double: 66.9 x 5.3 x 0.9

King: 74.4 x 5.3 x 0.9

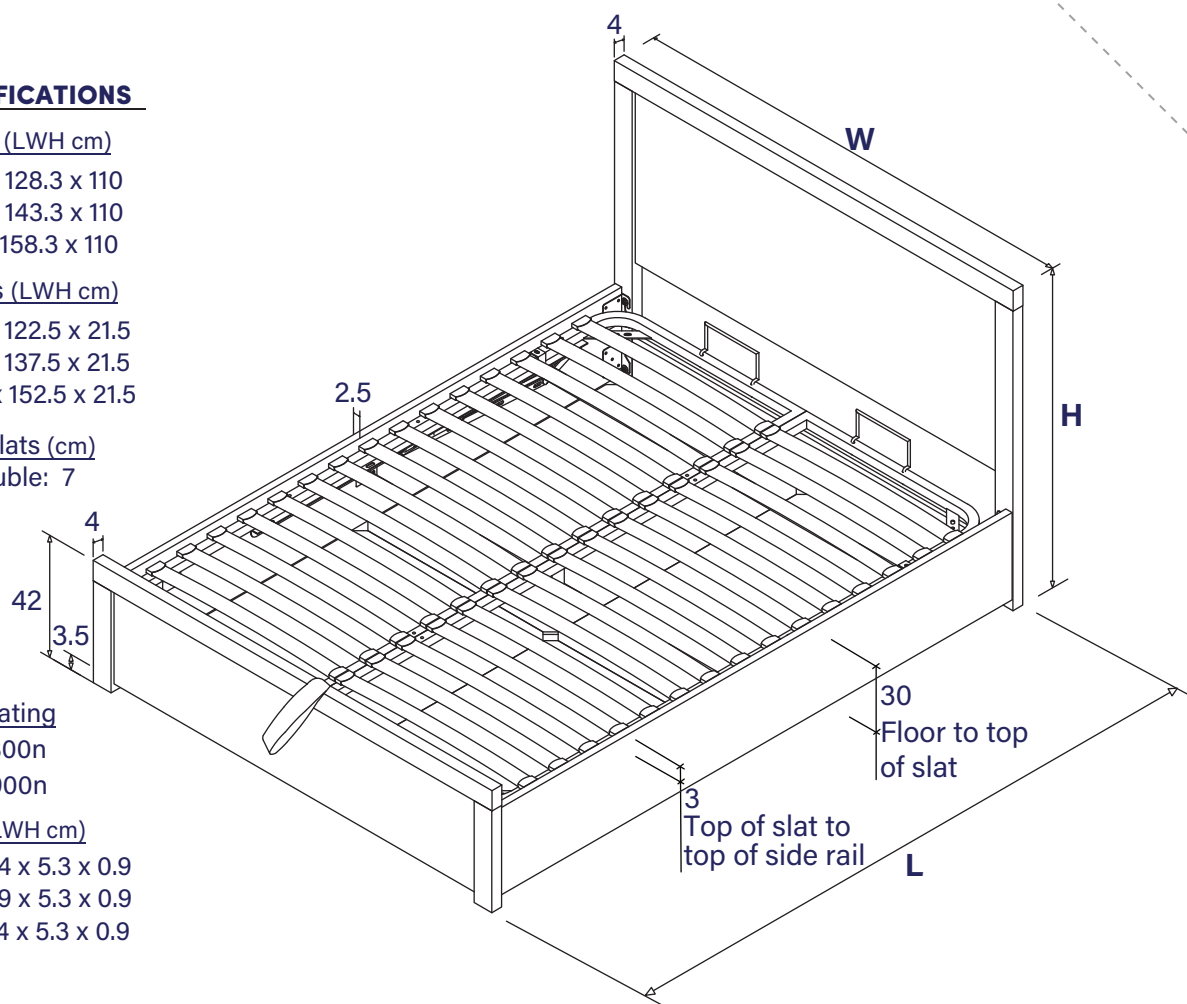

Care and maintenance

Here are some tips to keep your new bed in tip-top condition



Cleaning

To clean your new bed, we'd advise using a warm damp cloth or if fabric, remove dust using a low suction vacuum cleaner - please do not use abrasive chemicals or bleach as this may damage the product.



Checking and moving

Periodically we recommend you check that the screws or fixtures haven't become loose, over time. To move your new bed, we recommend lifting it where possible, as dragging or pushing it could cause damage to your flooring.



Wood

Please note each of our wooden pieces are unique, meaning that markings and shade can vary slightly between beds. Over a period of time, the wood might lighten or fade slightly due to light exposure.



Fabric

Please note depending on the lighting, positioning and surroundings of your room, the shade of the colour can sometimes appear slightly different. Over a period of time the colour might lighten or fade slightly due to light exposure.



Metal

Metal tends to be more resilient to everyday wear and tear. We recommend to gently dust your metal furniture and keep it dry to maintain its look.

Thank you for shopping with us - we hope you have a great night's sleep

Sleep well



Little dreamers

Keep the little ones entertained while you assemble your new purchase.



Dreams