

Stompa®

www.stompa.com

Art.nr. A002

- (N) Gavler
- (GB) Gable ends
- (D) Giebelbretter

Art.nr. A003

- (N) Sengeramme
- (GB) Bedframe
- (D) Bettrahmen

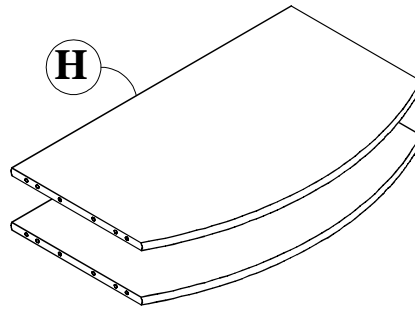
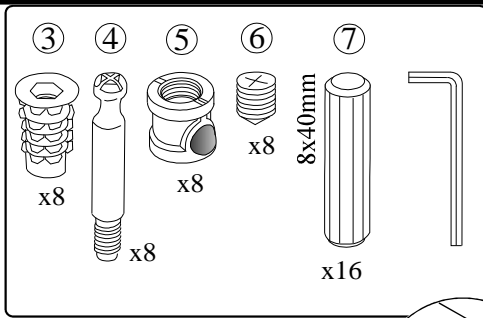
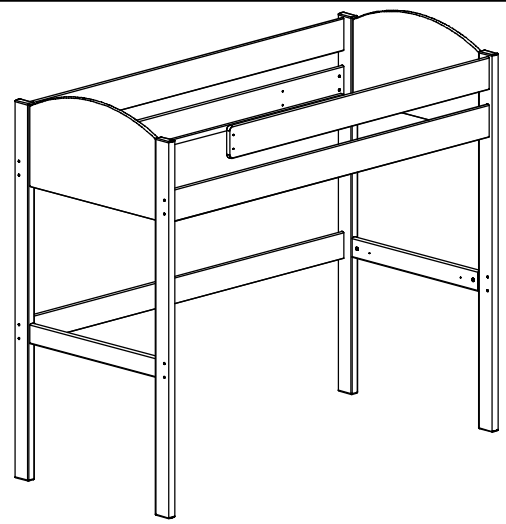

A002

Du trenger også et stjerne-skrudern og en hammer.
You also need a crosshead screwdriver and a hammer.
Zusätzlich brauchen Sie einen Kreuzschraubenzieher und einen Hammer.

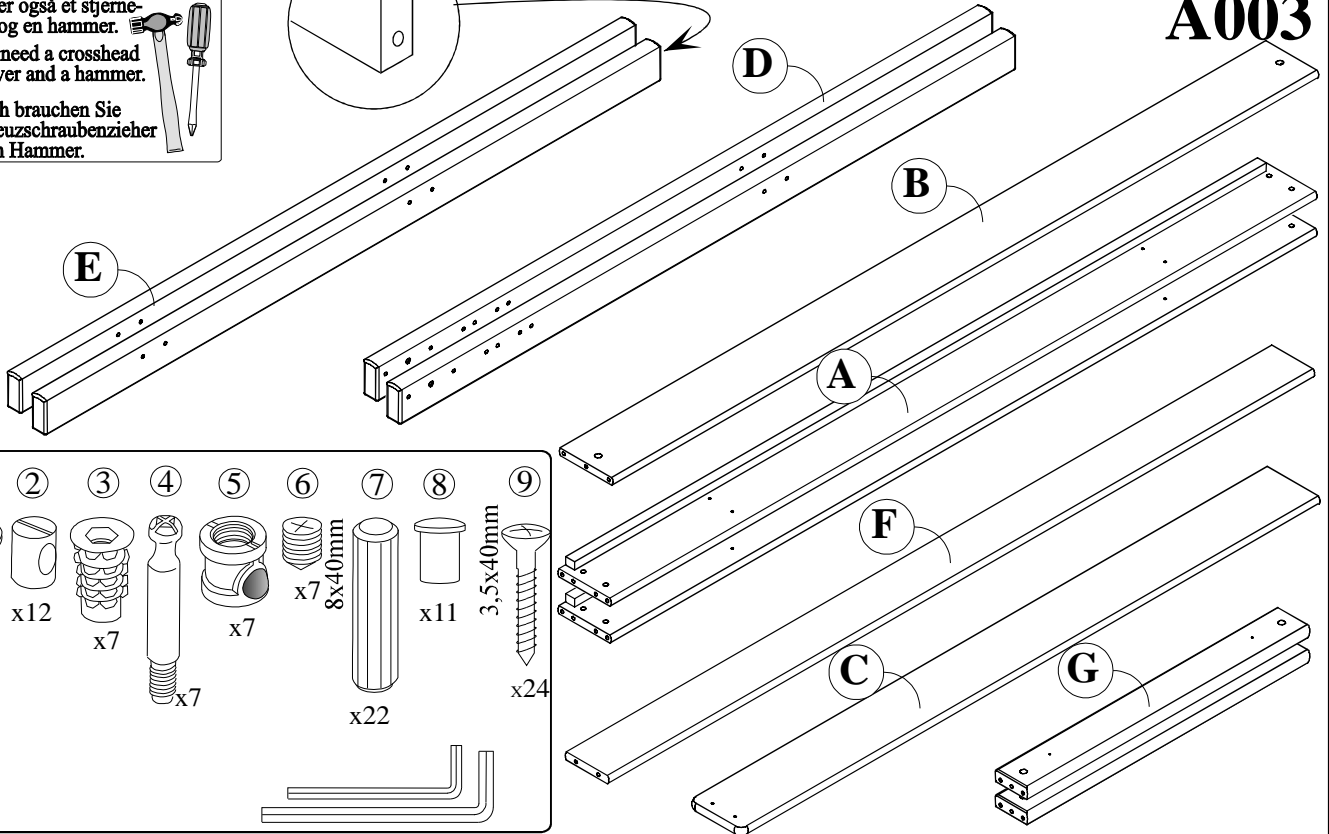
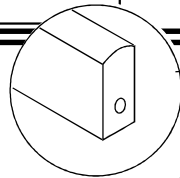

A003

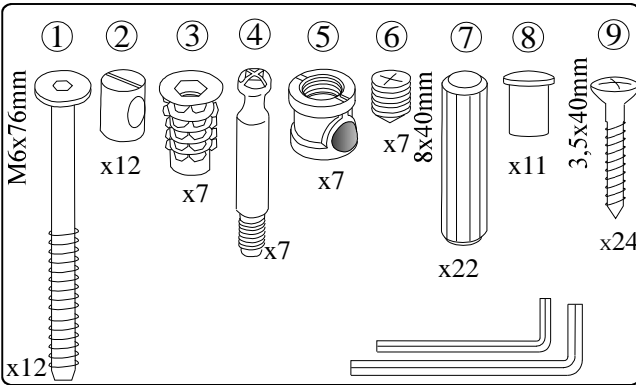

United Kingdom:

If anything should fail to give satisfaction, please contact your STOMPA stockist with details of any problems with the product. Please quote Art number & serial number on any correspondence.

Stompa UK
The Old Mill House
Dockfield Road, Shipley
West Yorkshire, BD17 7AE
E-mail: stompa@stompa.co.uk
www.stompa.co.uk

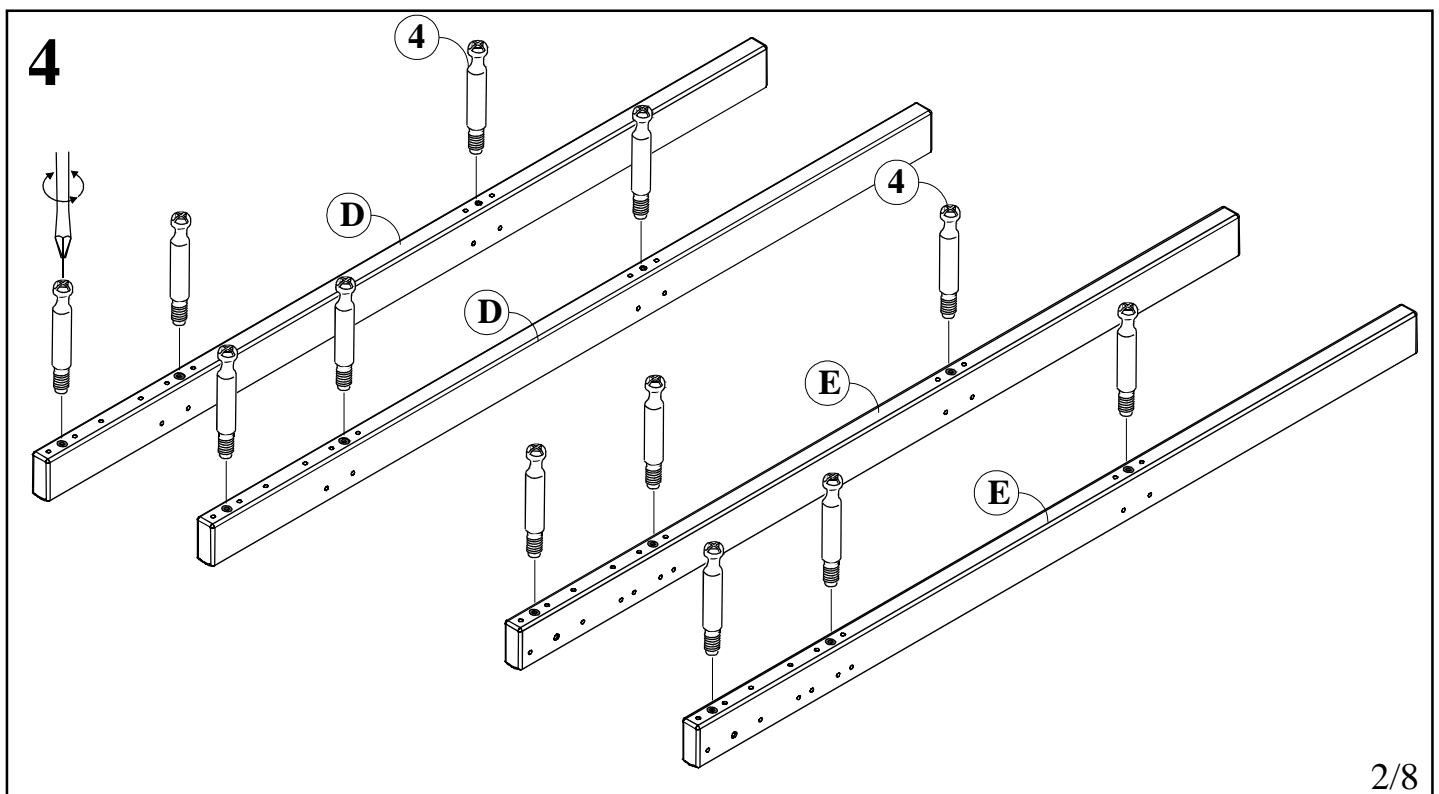
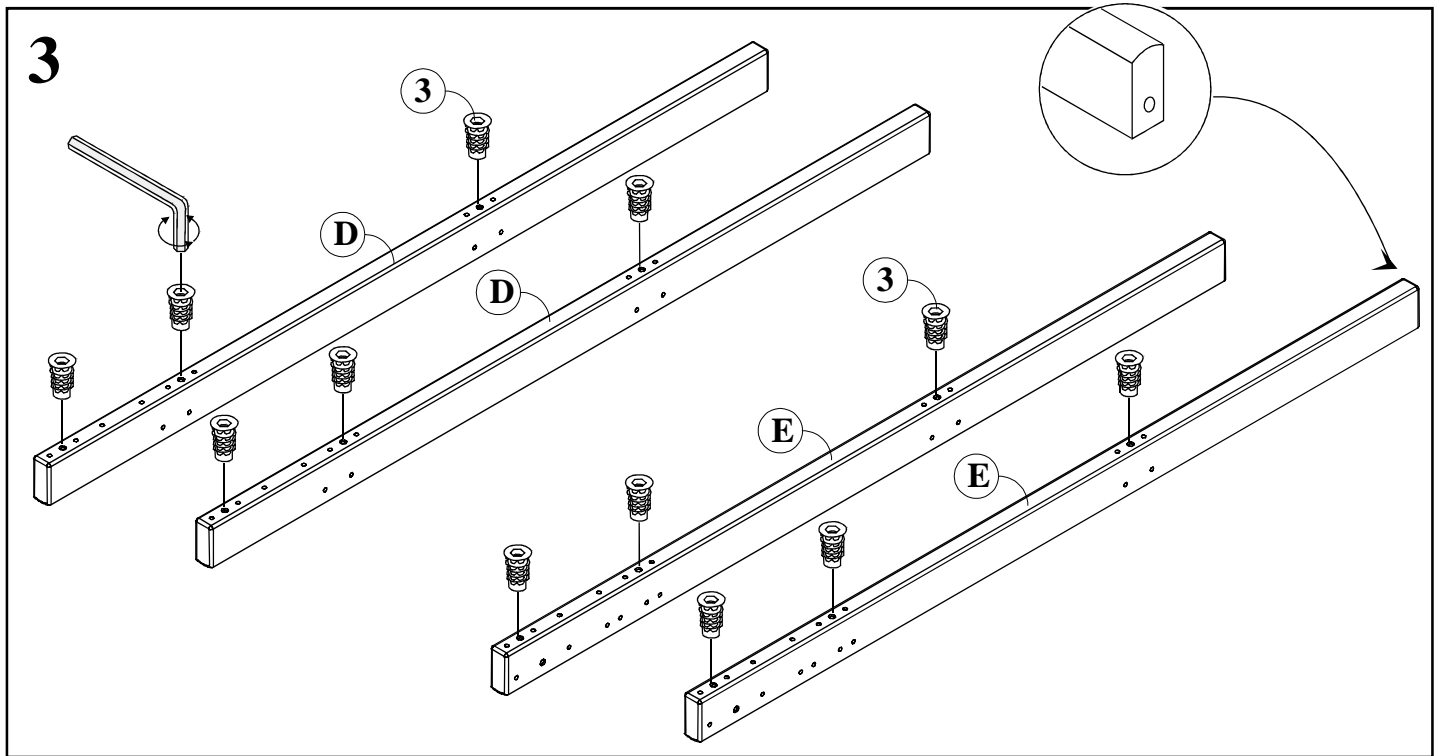
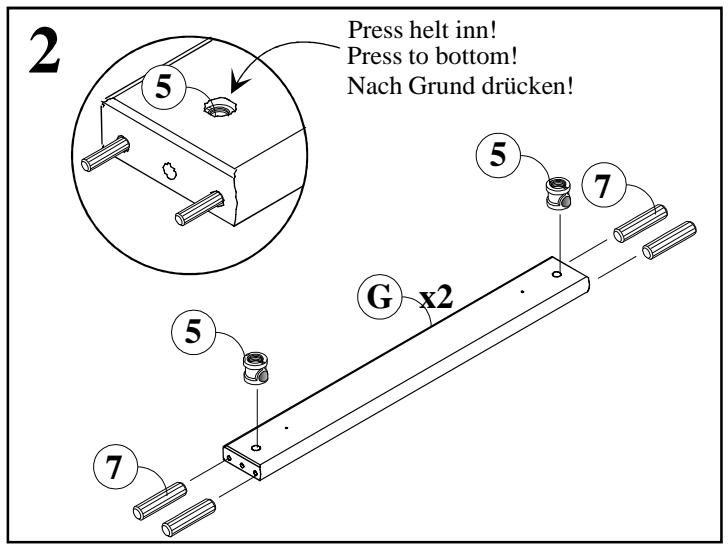
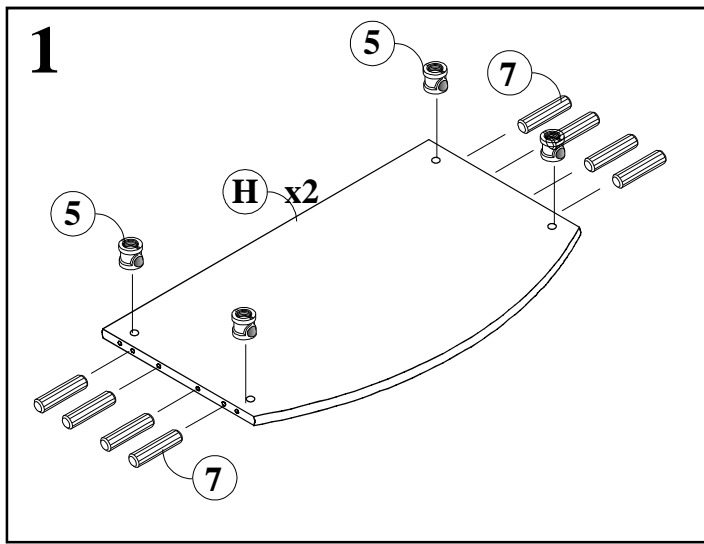

5

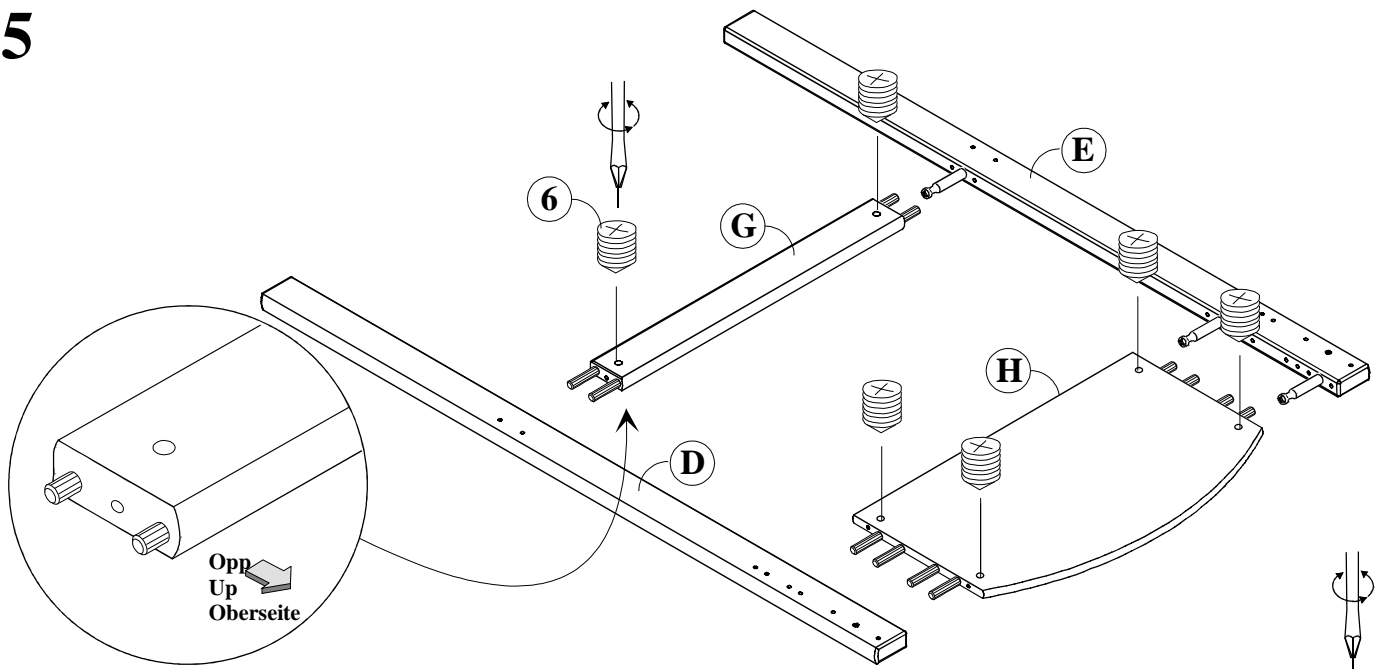

6

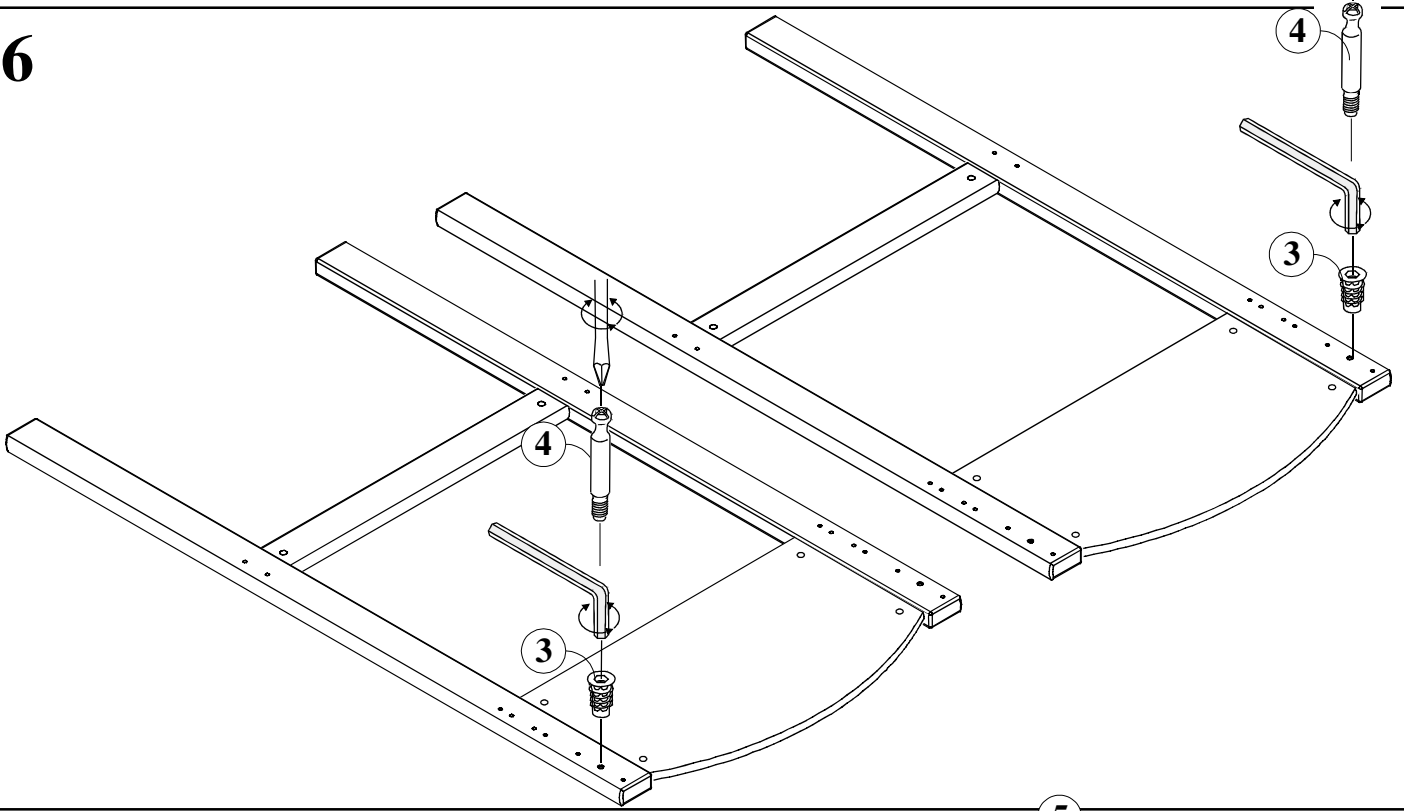

7

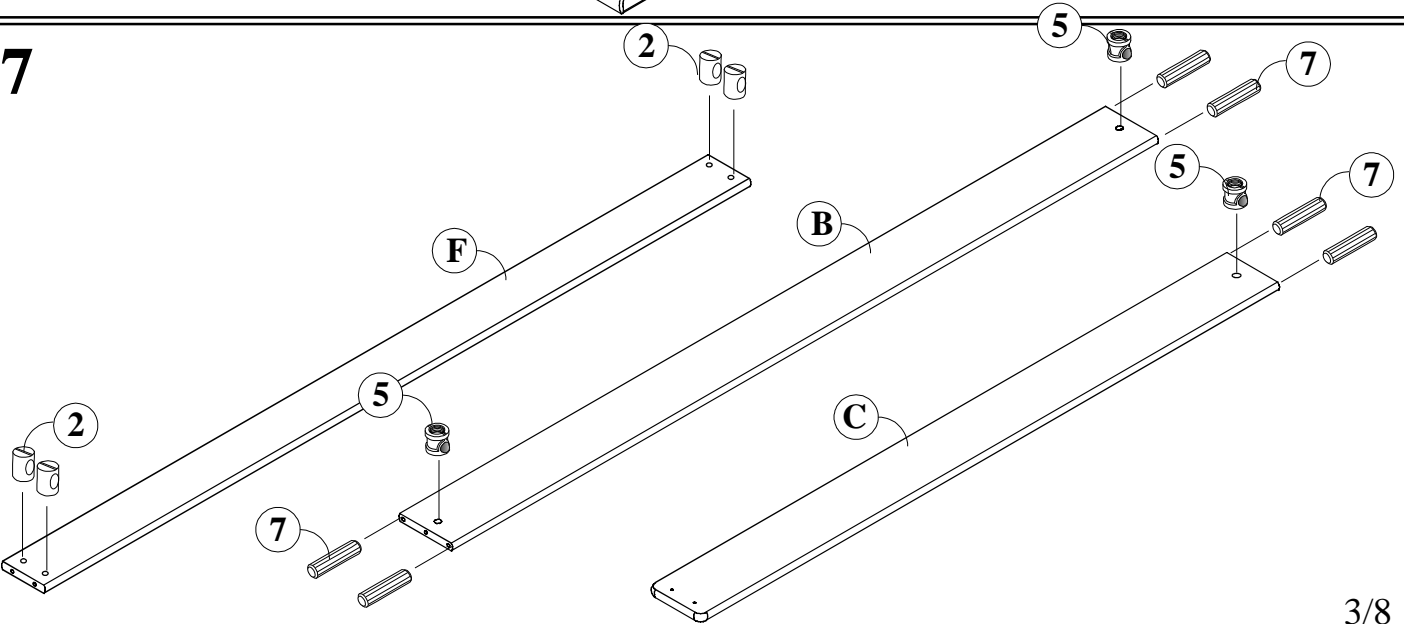

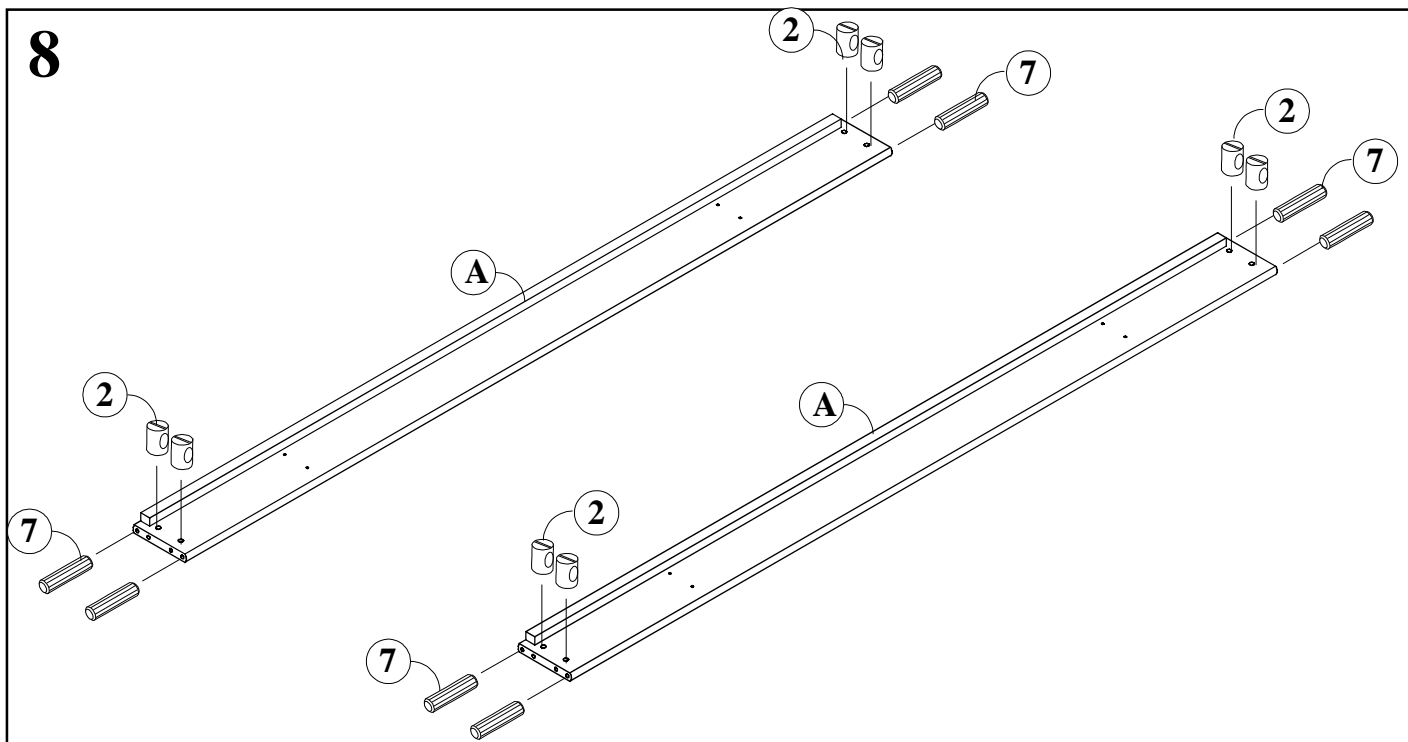
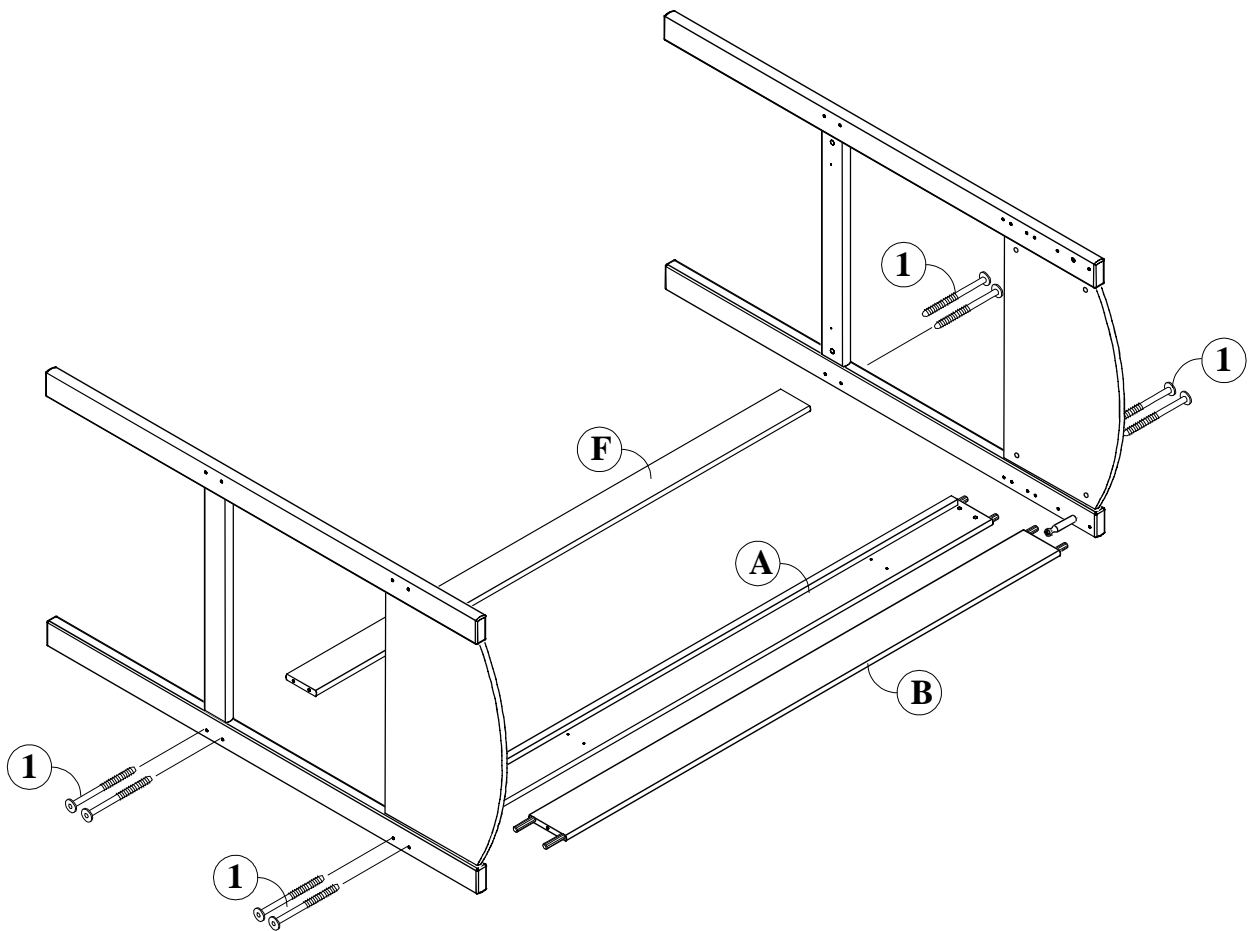
8**9**

Bruk sølvskruer til en hvit seng, og messingskruer til en syrebeiset seng.
 Use silver screws to a white bed, and brass screws to a sienna bed.
 Benutzen Sie bitte die silberfarbigen Schrauben fuer ein weisses und
 die messingfarbigen Schrauben fuer ein antik lackiertes Bett.

10

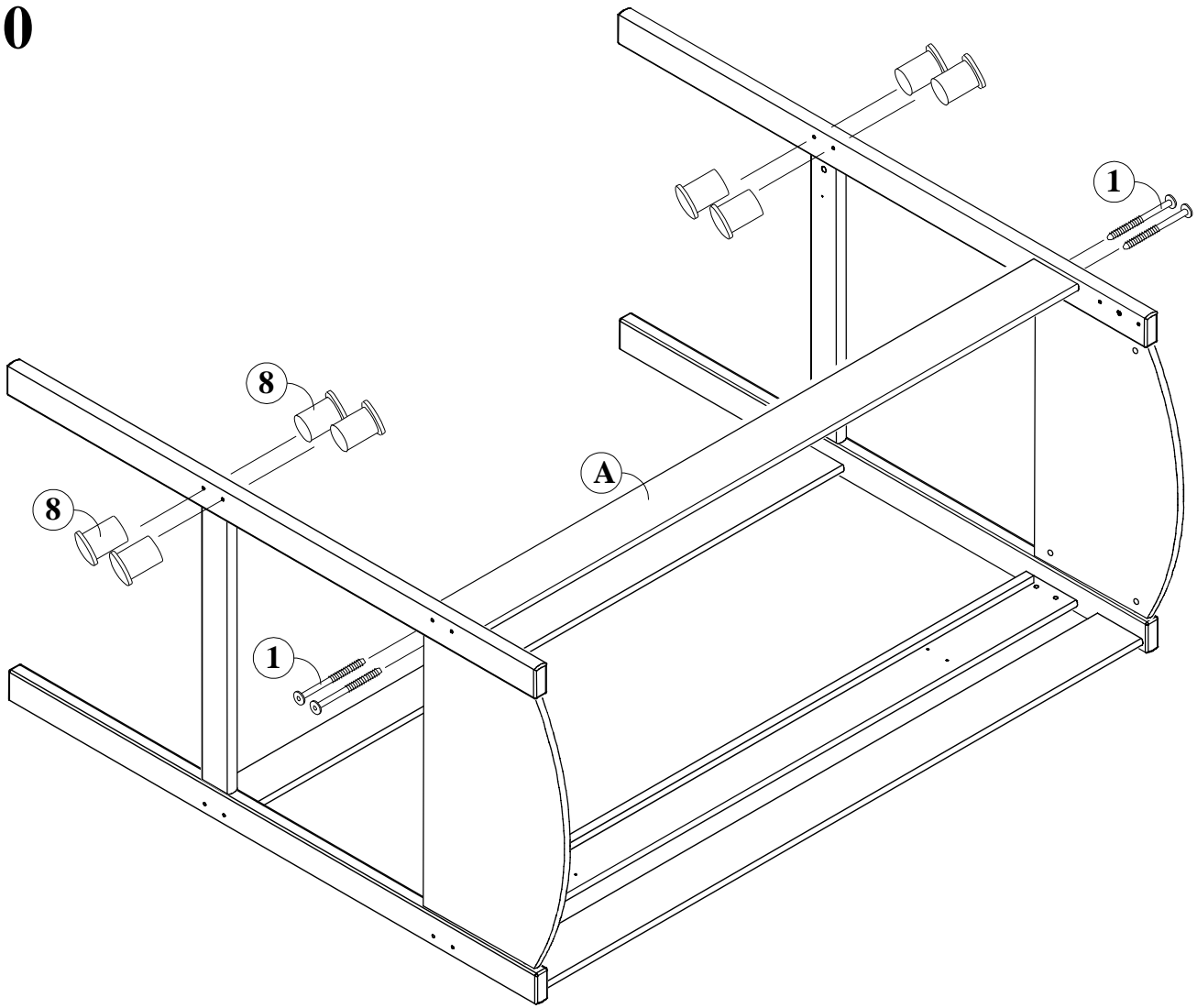

11

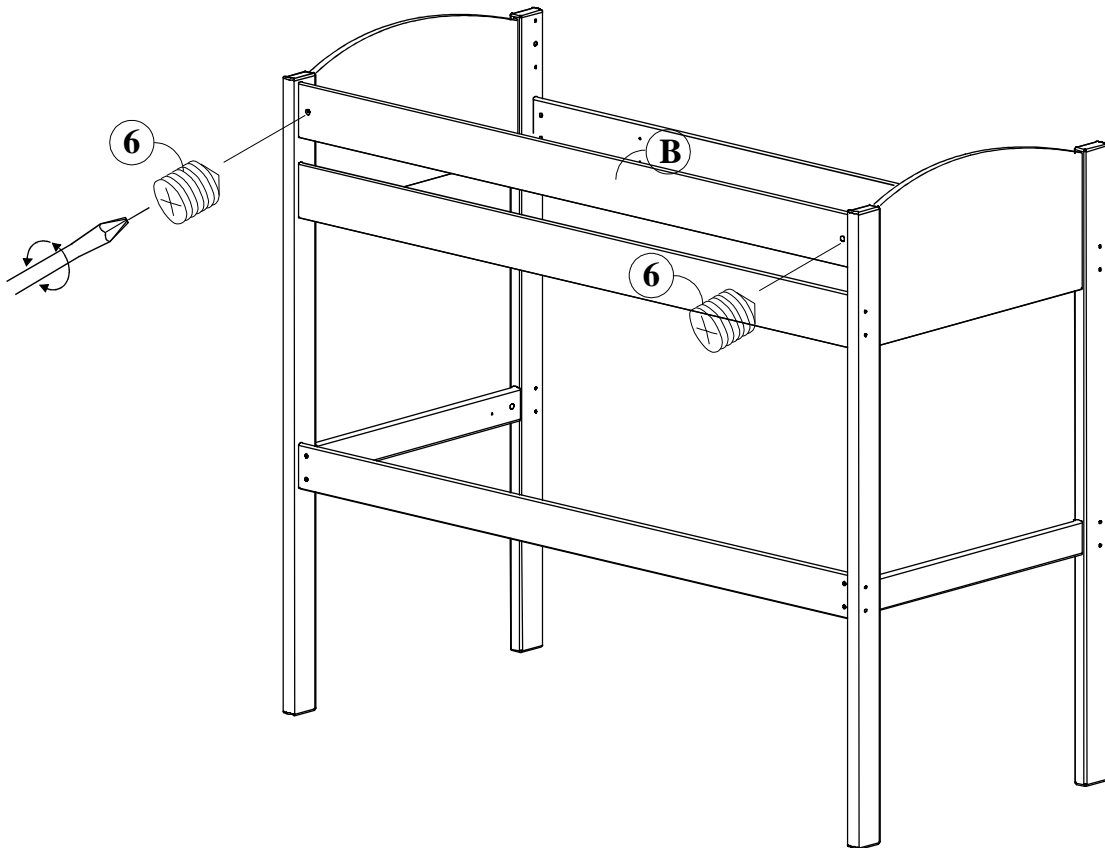

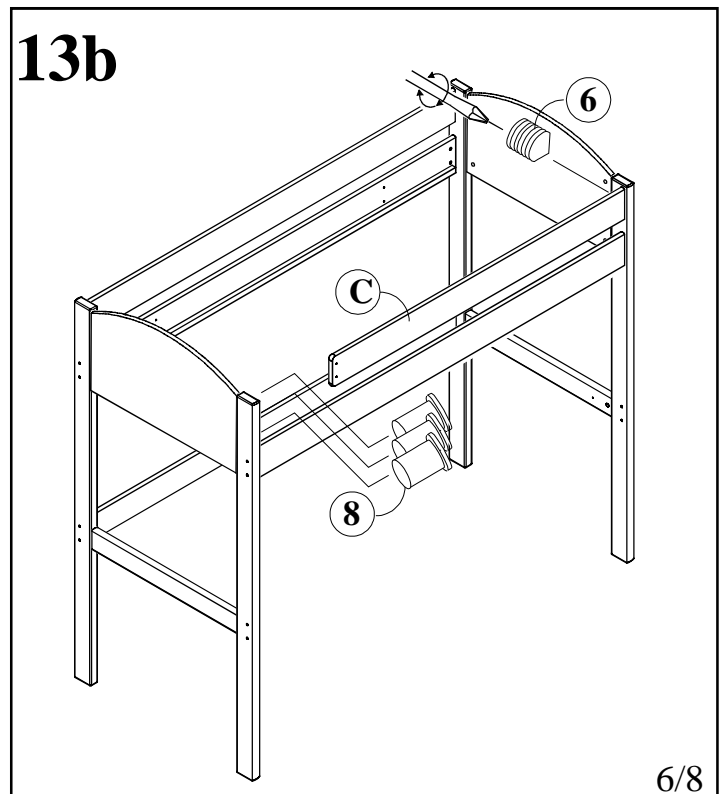
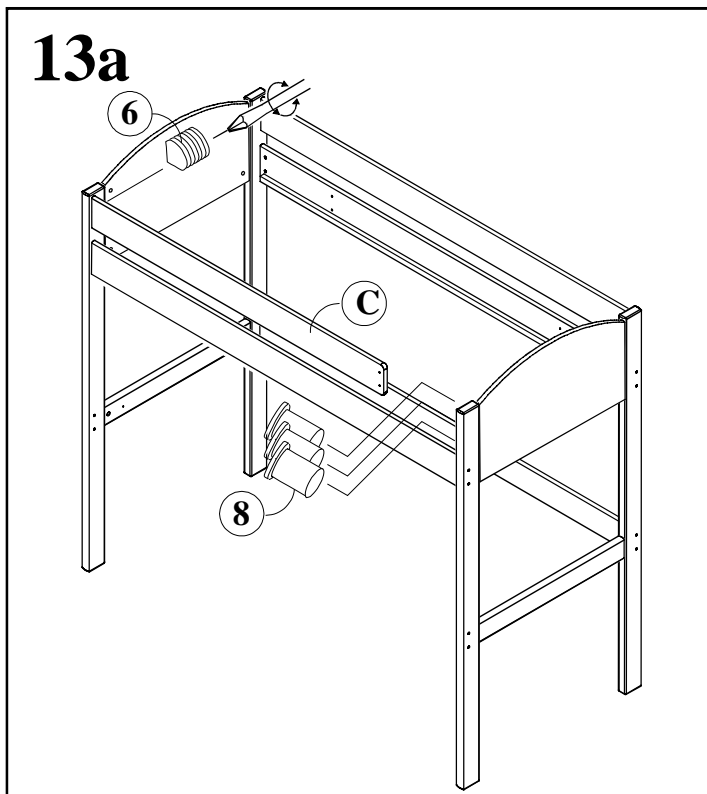
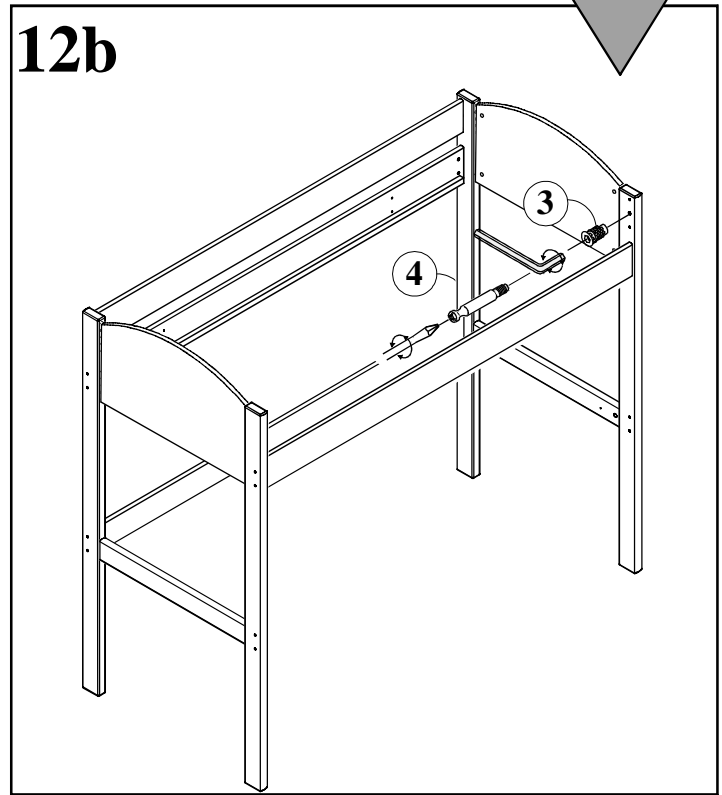
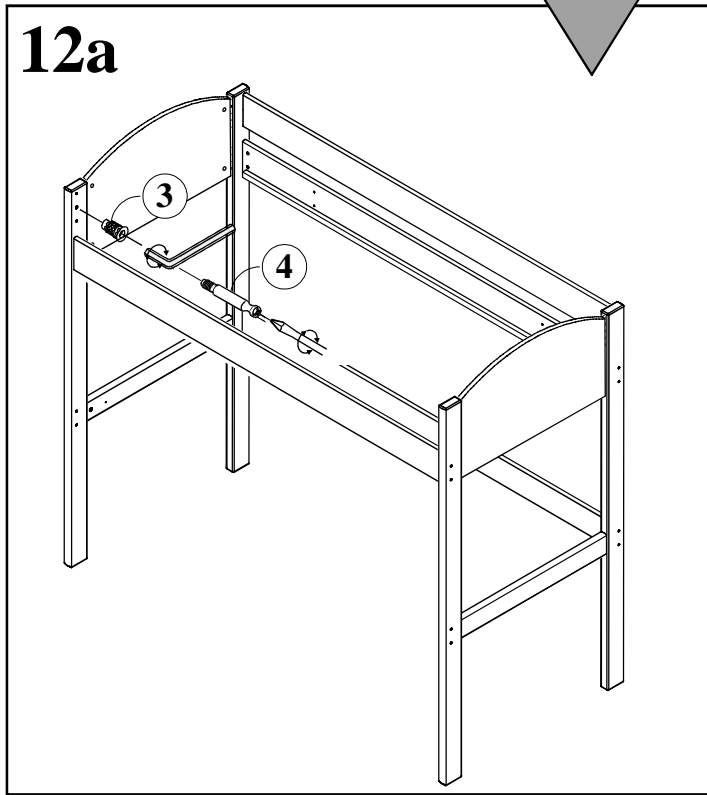
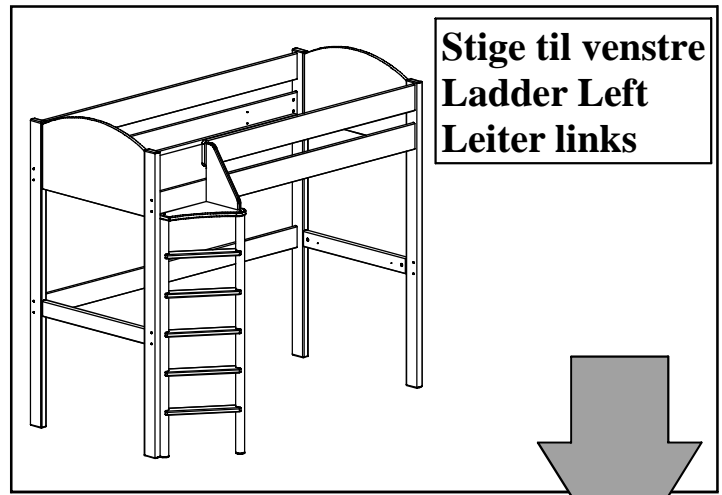
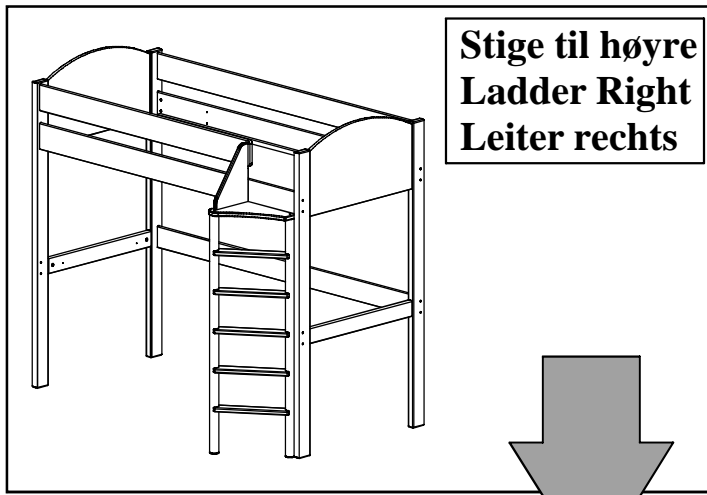

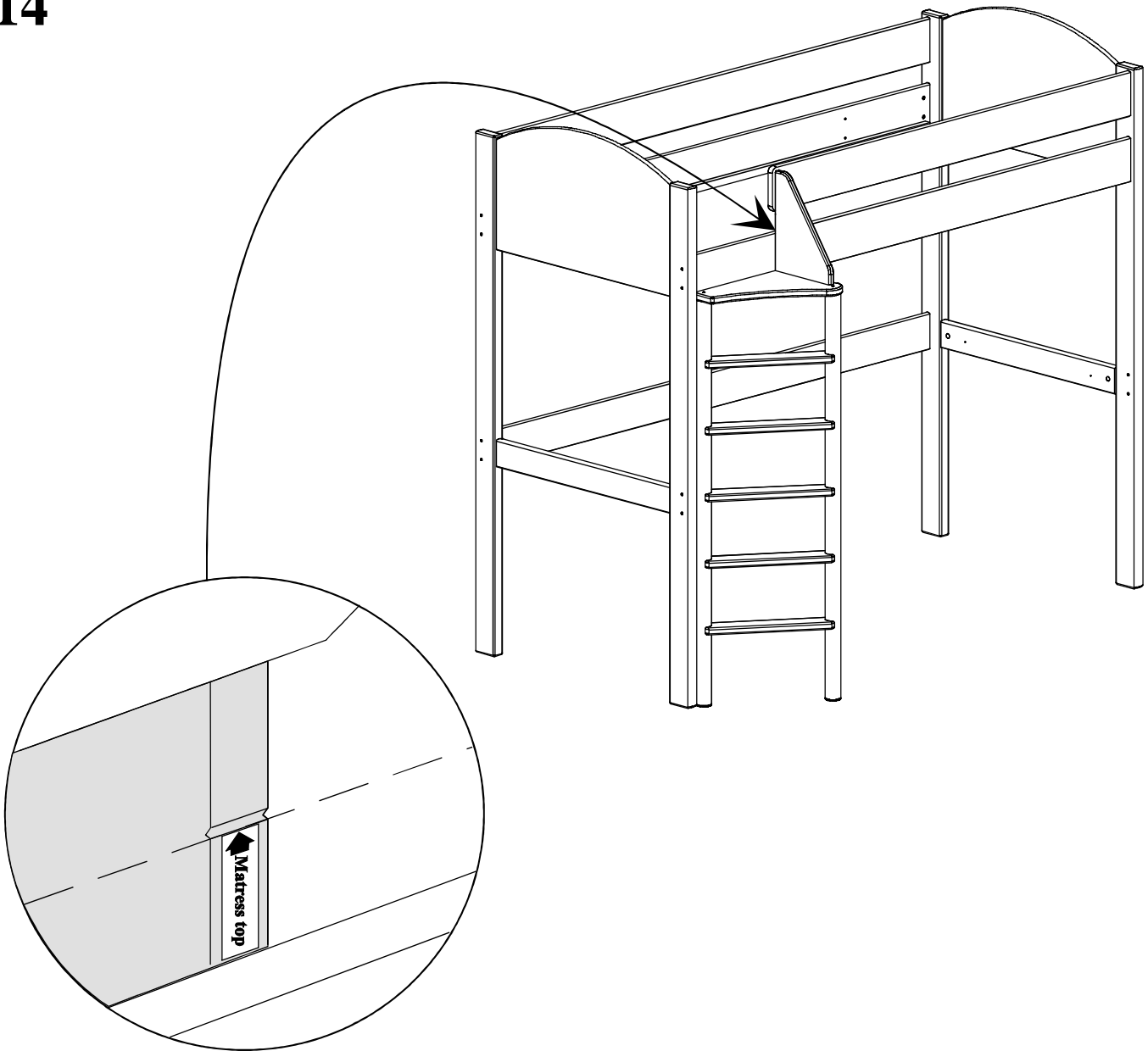

I henhold til Norsk Standard og Europas norm NS-EN 747 "Møbler - køyesenger til bruk i boliger", anbefales det at følgende retningslinjer blir fulgt:

1. STOMPA gjør oppmerksom på markeringslinja på stigesiden. Toppen på madrassen skal ikke være høyere enn denne markeringslinja. Det anbefales en madrassstørrelse på 90x200cm.
2. Vær oppmerksom på at barn (under 6) kan falle ut av overkøya.
3. Barn bør ikke leke i overkøya.
4. STOMPA anbefaler at sikkerhetsbrett, stige og andre deler kontrolleres regelmessig. Dette for å påse at delene er i god stand og at de sitter på plass. Trekk til skruene om nødvendig.
5. Dersom enkelte deler må byttes ut, bør disse bestilles fra forhandleren. Kun originale deler skal benyttes.
6. Sengebunnene skal skrues fast. Sørg for at mellomrommet mellom hver spile ikke er større enn 75 mm. Minimum 3 spiler bør skrues fast.

In compliance with EN 747-1 1993 "Furniture - Bunk Beds for Domestic use", please study the following guide lines:

1. Be aware of the mattress line on the ladder side. Please ensure that the mattress does not extend above the mattress line. Mattress of 90x200 cm is recommended.
2. Be aware of the danger of young children (under 6) falling from the upper bunk.
3. Children should be discouraged from playing on the bunk bed.
4. We recommend that a periodic check is made, to ensure that guard rails, ladder and other components are in correct position, that they are in good condition and that the fittings are tight.
5. If replacement parts are required, please order these from your furniture dealer. Substitute parts must not be used.
6. When using a slatted bottom, ensure when securing slats that the gaps between them are no more than 75mm. Each slat must be screwed into place.

Gemäß der EN 747-1 1993 "Möbel - Etagenbetten für den Wohnbereich", beachten Sie bitte die folgenden Richtlinien:

1. Bitte beachten Sie die Markierungslinie an der Leiterseite. Die Matratze soll nicht höher als diese Markierungslinie sein. Eine Matratze von 90x200 cm wird empfohlen.
2. Beachten Sie die Gefahr dafür, daß kleine Kinder (unter 6 Jahre) vom oberen Bett hinunterstürzen können.
3. Den Kindern sollten vom Spielen im Hochbett abgeraten werden.
4. Wir empfehlen Ihnen eine zeitweise Kontrolle durchzuführen um zu sichern, daß die Absturzsicherungen, die Leiter und andere Teile sorgfältig festgeschraubt sind.
5. Wenn Ersatzteile benötigt werden, bitte bestellen Sie diese bei Ihrem Möbeldändler. Nur Originale Teile sind zu verwenden.
6. Wenn einen Lattenrost benutzt wird, bitte sorgen Sie dafür, daß alle Latten, in einem Abstand von höchstens 75 mm voneinander, festgeschraubt werden.

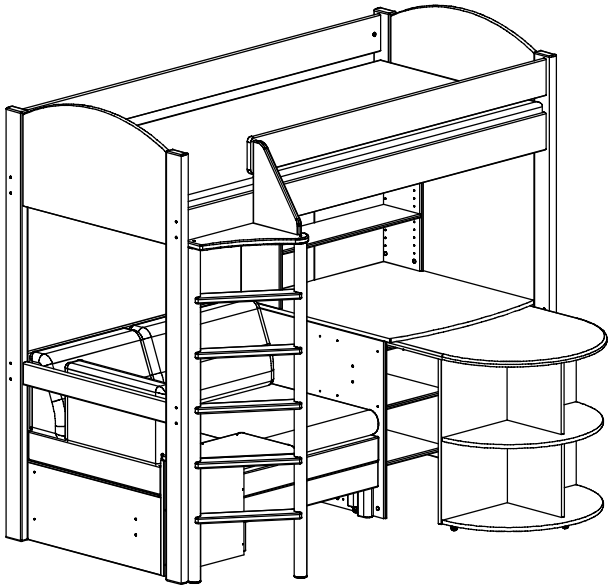

Art.nr. 104

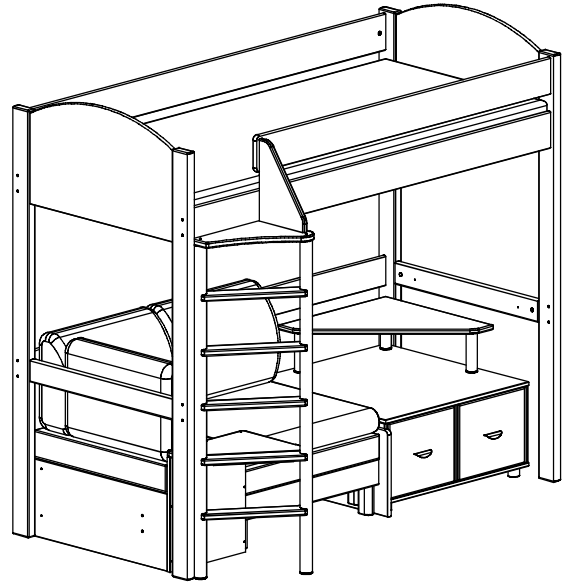

Art.nr. 105

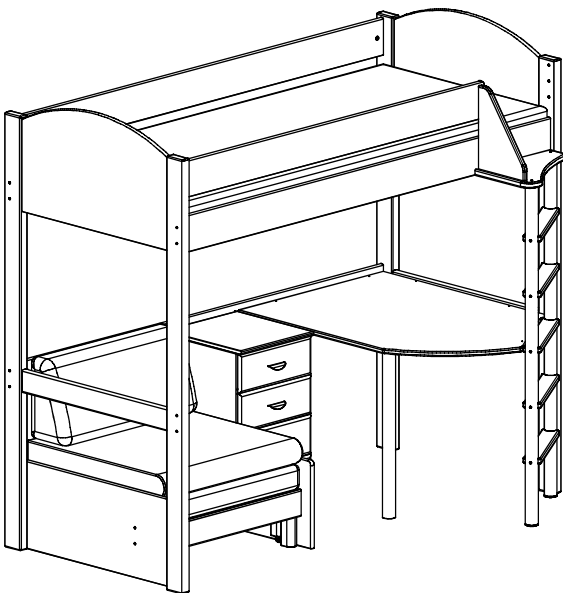

Art.nr. 121

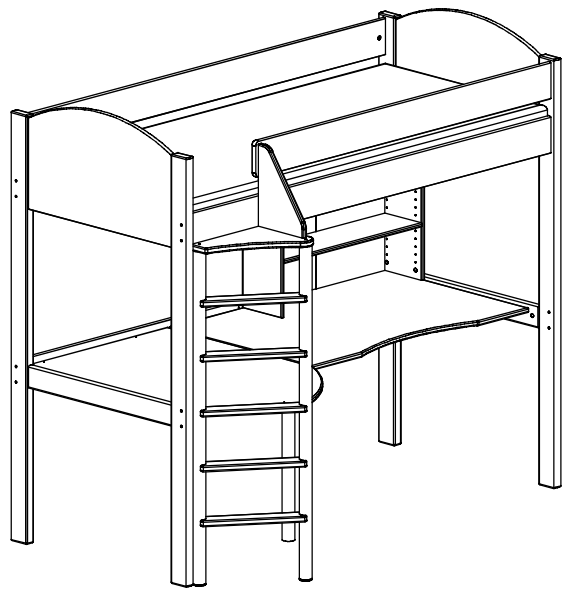

Art.nr. 112