

991 799

MONTAGEANLEITUNG INSTRUCTIONS DE MONTAGE ASSEMBLY INSTRUCTIONS MONTAGEAANWIJZING

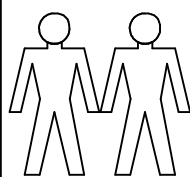

D - Beispiel
GB - example
FR - exemple
NL - voorbeeld
CZ - příklad
SLO - primer
H - példa
RO - Exemplu
I - Esempio
RUS - пример
TR - Örnek
PL - Przykład
E - Ejemplo
P - Exemplo

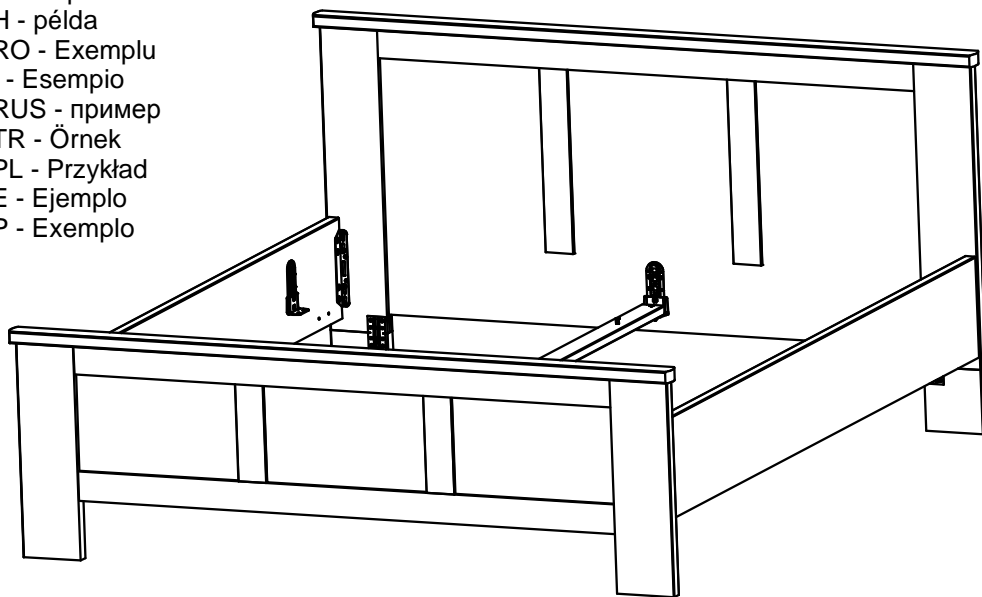

DEUTSCH - Alle Pakete öffnen und alle Aufbauanleitungen lesen. Fachkundige Montage erforderlich. Unsachgemäße Montage kann zu Unfällen führen. Möbel/Gegenstand könnte kippen oder umfallen. **WICHTIG!** Achten Sie darauf, dass Sie Schrauben/Beschläge entsprechend der Wand-/Deckenbeschaffenheit und mit ausreichender Tragfähigkeit verwenden. Erkundigen Sie sich ggf. beim Eisenwarenfachhandel.

NEDERLANDS - Alle pakketten kunnen openen en lezen alle montage-instructies. De montage dient te worden uitgevoerd door een vakbekwaam iemand. Foutieve montage kan er toe leiden dat het meubel/voorwerp kantelt of omvalt en iets beschadigt resp. iemand bezeert. N.B. Denk er aan dat de schroeven of het beslag dat je kiest geschikt moeten zijn voor de wand/het plafond waarin ze vastgezet moeten worden, en voldoende draagkracht moeten hebben. Neem bij twijfel contact op met de lokale vakhandel.

ENGLISH - All packages can open and read all the assembly instructions. The assembly should be carried out by a qualified person, due to the fact that wrong assembly can lead to that the furniture/object topples or falls resulting in personal injury or damage. **NOTE!** Choose screws and fittings that are specially suited to the material in your wall/ceiling and have sufficient holding power. If you are uncertain, contact your local specialised retailer.

POLSKI - Wszystkie pakiety mogą otworzyć i przeczytać wszystkie instrukcje montażu. Mebel powinien być montowany przez osobę do tego uprawnioną. Następnym niewłaściwego montażu mebla może być przechylenie lub nawet przewracanie się mebla, w wyniku czego może dojść do uszkodzenia mebla i jego zawartości a nawet do wypadku. **UWAGA!** Okucia, śruby, haki jak i kołki muszą być dopasowane do wagi mebla z zawartością oraz do specyficznych właściwości muru lub sufitu. W przypadku wątpliwości prosimy zasięgnąć porady fachowca.

FRANÇAIS - Tous les forfaits peuvent ouvrir et lire toutes les instructions de montage. Le montage doit être effectué par une personne compétente. Un montage mal effectué peut provoquer la chute du meuble/de l'objet et blesser quelqu'un. **ATTENTION!** Adaptez les vis et ferrures au matériau du mur/plafond et au poids de l'objet. En cas de doute, demandez conseil à un vendeur spécialisé.

MAGYAR - Minden nyitott csomagokat és az összes összeszerelési utasításokat olvasni. Az összeszerelés lehetőleg hozzáértő személy végezze, mert nem megfelelő, hibás össze-, ill. felszerelés esetén a bútor feldőlhet, leszakadhat a falról, ezzel személyi sérülést vagy balesetet okozva. **FIGYELEM!** Válasszon olyan csavart, tipilt mely leginkább alkalmas az Ön otthonában található fal / mennyezeti anyagához, és teherbíró képessége is megfelelő.

Русский - Все пакеты можно открыть и прочитать все инструкции по сборке. монтаж должен производиться специалистом. Неправильная установка может привести к несчастному случаю. Мебель может опрокинуться или упасть. **ВАЖНО:** Следите за тем, чтобы выбранные шурупы и другие крепежно-монтажные детали были достаточно прочно закреплены. Подробную информацию можете получить в специальных магазинах.

Česky - Všechny otevřené balíky a všechny montážní pokyny přečtete. Montáž by měl provést kvalifikovaný odborník. Nesprávná montáž může způsobit, že nábytek se může převrátit nebo se některý díl uvolnit. Může tak dojít ke zranění člověka či dalším škodám. **UPOZORNĚNÍ:** zvolte šrouby a kování, které jsou vhodné pro daný typ nábytku a mají postačující spojovací nosnost. Nejste-li si jisti, obraťte se na nejbližší specializovaný obchod.

ITALIANO - Tutti i pacchetti aperti e leggi tutte le istruzioni per l'uso. Importante un montaggio corretto. Un montaggio sbagliato può causare incidenti. Assicurarsi di fissare il mobile alla parete o al soffitto con viti/accessori adatti in modo che non può ribaltarsi o cadere. Usare solo ferramenta speciale. Il produttore non si assume nessuna responsabilità in caso di danni a persone o cose.

Español - Todos los paquetes pueden abrir y leer todas las instrucciones de montaje. Montaje de expertos necesario. Un montaje inadecuado puede dar lugar a accidentes. Muebles/objeto podría inclinar o caerse. **¡IMPORTANTE!** Asegúrese de que utilice los tornillos / accesorios de acuerdo con las propiedades adecuadas para pared / techo y con capacidad de peso suficiente. Infórmese en su ferretería.

Türkçe - Tüm paketler tüm montaj talimatları açıp okuyabilirsiniz. Uzman bir kişi tarafından montaj edilmelidir. Yanlış bir kurulum mobilyanızın üzerinize düşmesine ve/veya tamamen dağılmasına neden olabileceği için kazalara ve yaralanmalara yol açabilir. **ÖNEMLİ!** Lütfen Dikkat Ediniz. Duvar yapısına göre yeterli kapasitede ve tasıma kabiliyetinde olan vidalar/parçalar kullanınız. Gerekiirse bir uzman ve/veya yapı-market mağazasına danışabilirsiniz.

Português - Todos os pacotes podem abrir e ler todas as instruções de montagem. Montagem só de pessoas experientes. A montagem incorreta pode levar a acidentes. Móveis/objeto poderia cair. **IMPORTANTE!** Dê atenção que os parafusos / as guarnições correspondem à qualidade das paredes e que têm capacidade suficiente para a carga. Informa se eventualmente numa loja de ferragens.

SLOVENSKY - Vsi paketi lahko odprete in preberete vsa navodila za montažo. Montáž by mala vykonat' kvalifikovaná osoba. Pri nesprávnej montáži môže dôjsť k prevrhnutiu alebo pádu nábytku/objektu a k prípadnému zraneniu osôb alebo poškodeniu majetku. **UPOZORNENIE!** Použite skrutky a kovanie, ktoré sú vhodné na použitie do materiálu danej steny/stropu a majú dostatočnú nosnosť. Ak si nie ste istí, obráťte sa na špecializovaného predajcu.

Română - Toate ofertele se pot deschide și citi toate instrucțiunile de asamblare. Este necesar un montaj profesional. Un montaj neprofesional poate duce la accidente. Mobila / corpul de mobila se poate inclina și cadea. **IMPORTANT!** Asigurați-va ca suruburile și toate celelalte fitinguri se potrivească tipului de material din care este construit peretele sau tavanul și ca au o rezistență suficientă la preluarea sarcinii. Dacă este necesar, solicitați sprijin specializat în magazinul de fitinguri.

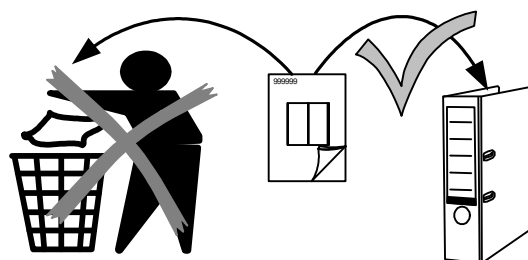

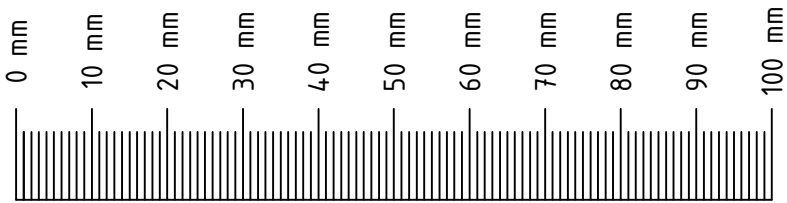
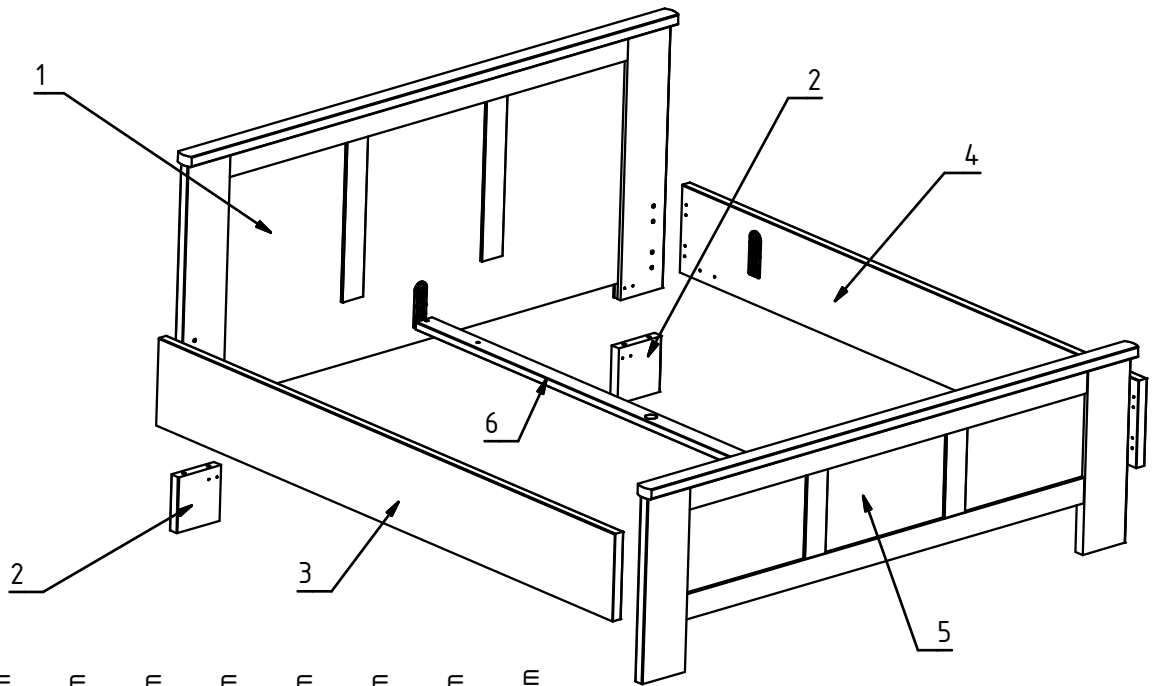

| | | | | | | |
|---------------------------|----------------|-----------------|------------------|----------------|-----------------|----------------|
| 8x 121 148 | 8x 111 112 | 8x 121 154 | 8x 121 359 | 4x 111 627 | 2x 111 622 | 2x 121 152 |
| 2x 124 560 Ø 10 mm | 2x 353 006 | 1x 111 625 | 1-2x 111 634 | | 16x 121 170 | 4x 111 133 |
| 8x 124 599 | 4x 114 183 | 16x 121 164 | 4x 353 014 | 1x 111 019 | | |



A

6,3x15



16x 121 170

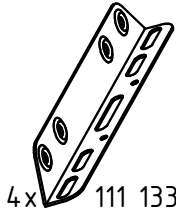

4x 111 133

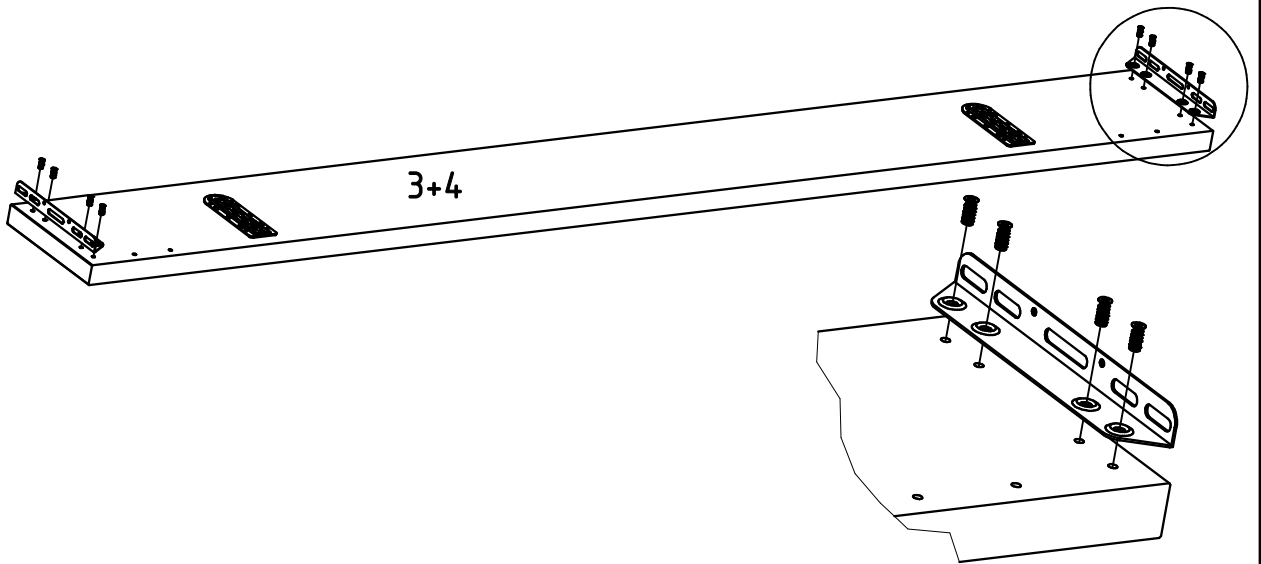

B

10x60

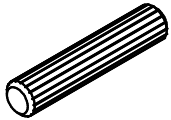

4x 353 014

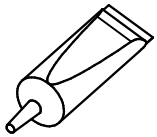

1x 111 019

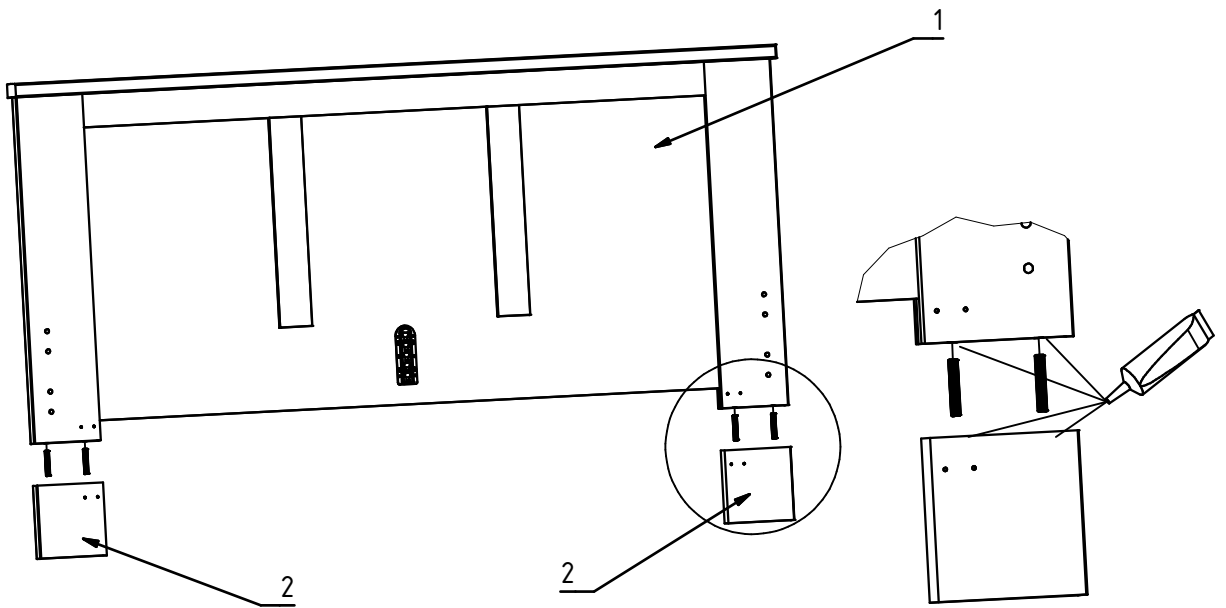

C

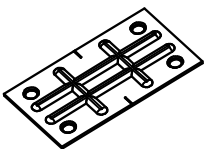

4x 114 183
3,5x22

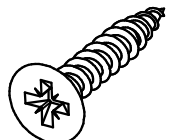

16x 121164

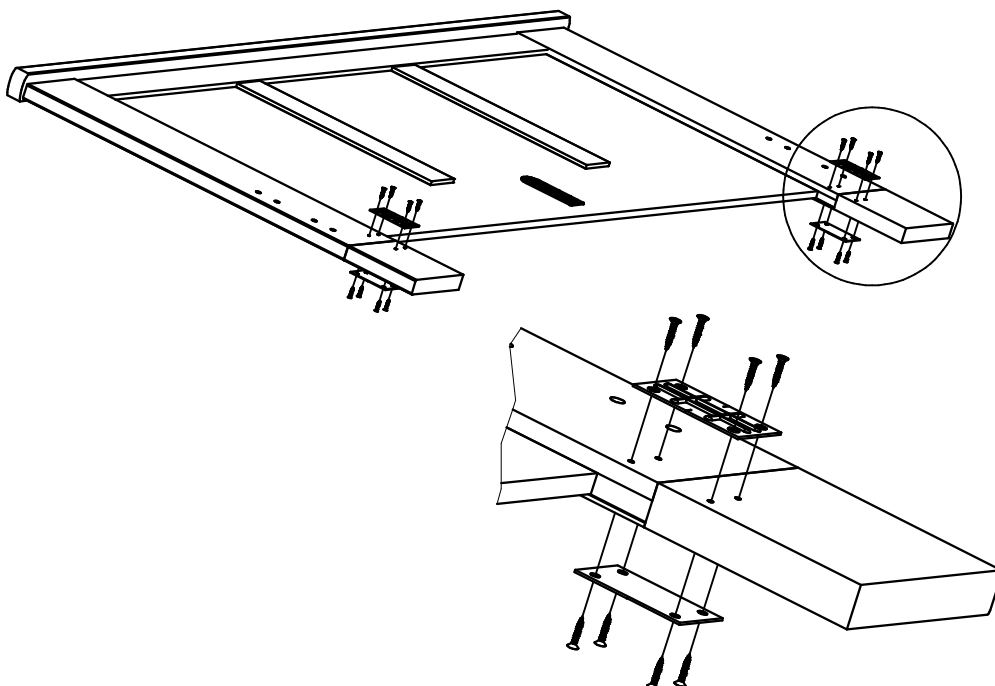

D

Ø 10 mm

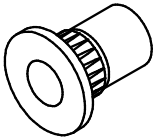
8x 124 599
M6x25

8x 121 154

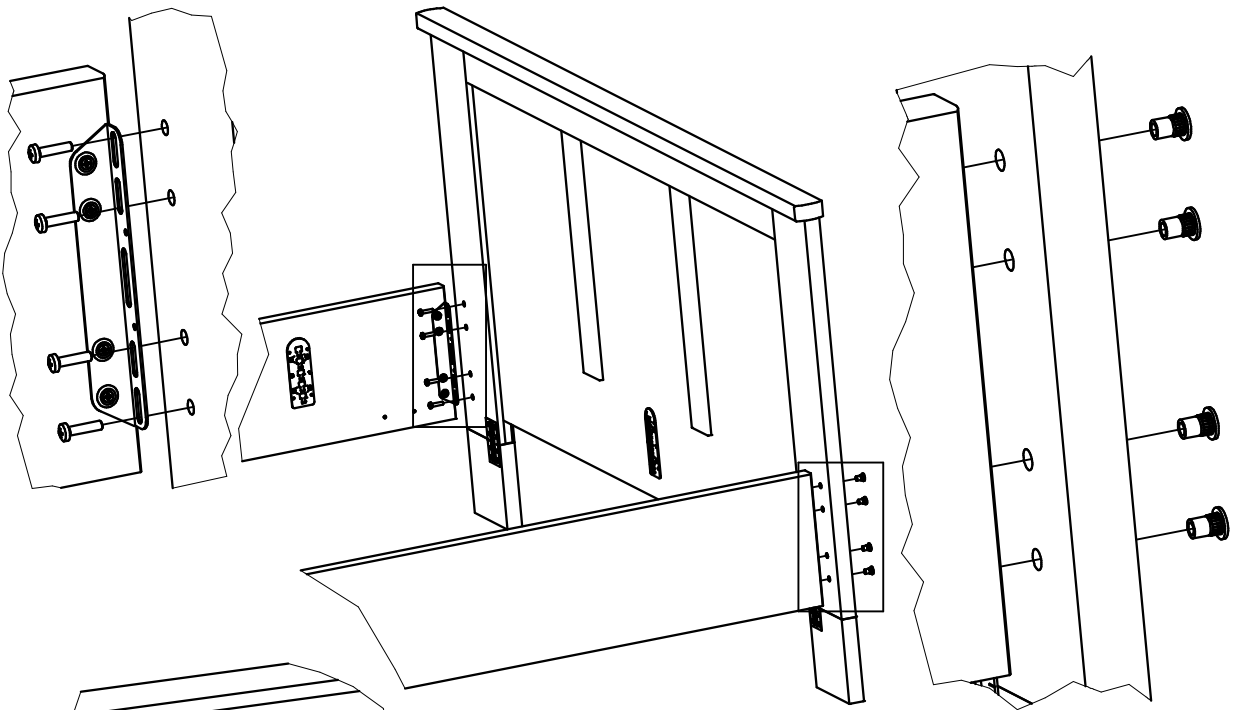
**E**

10 mm

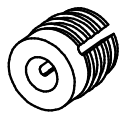

8x 111 112

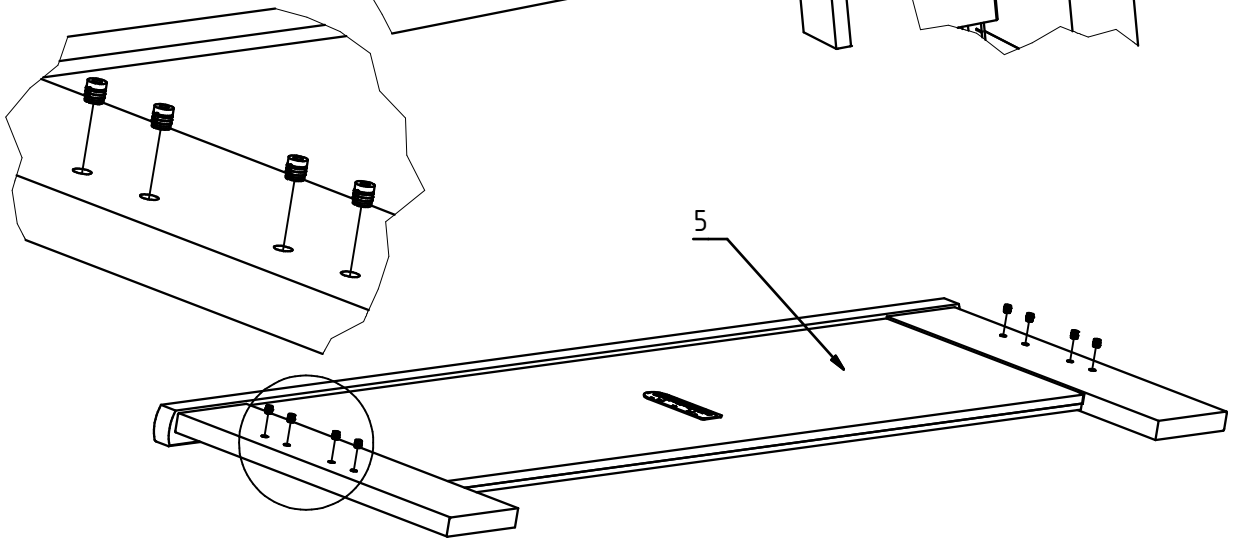
**F**

M6x12



8x 121 148

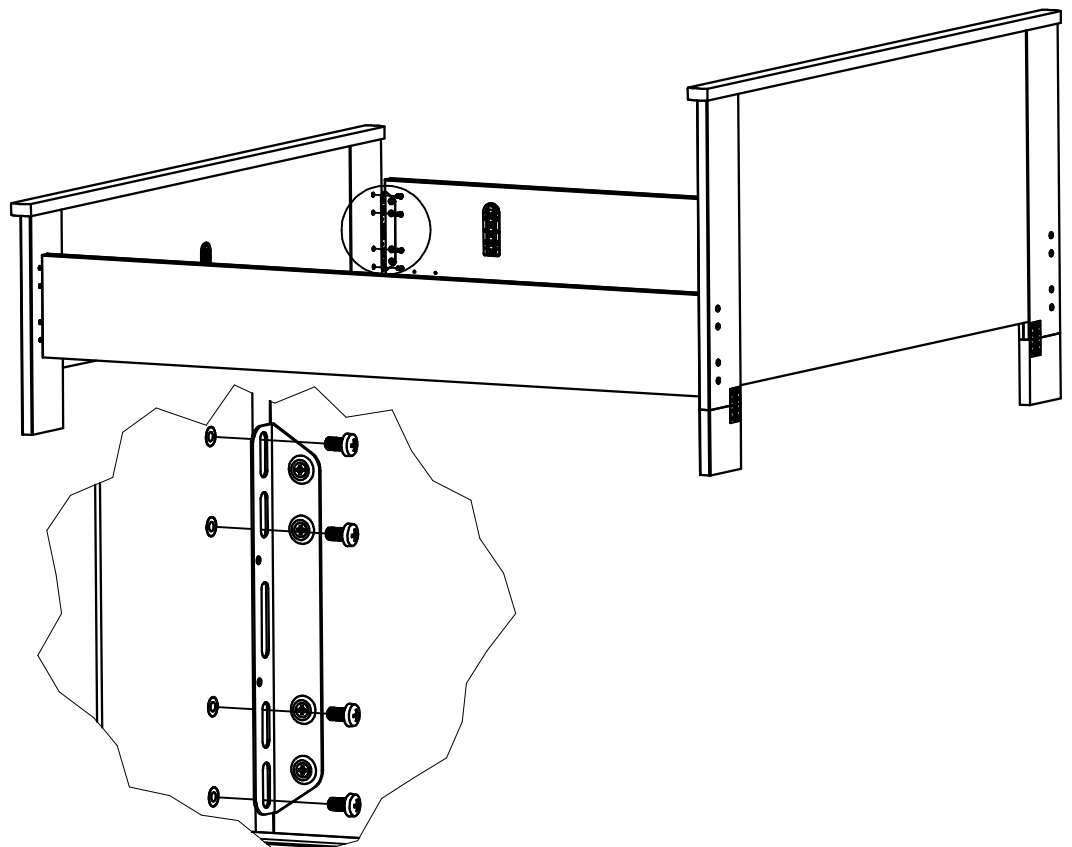

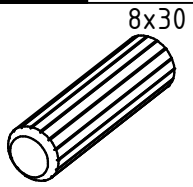
G

8x30

2x 353 006

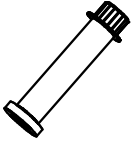

1x 111 625

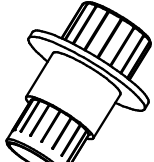

1-2x 111 634

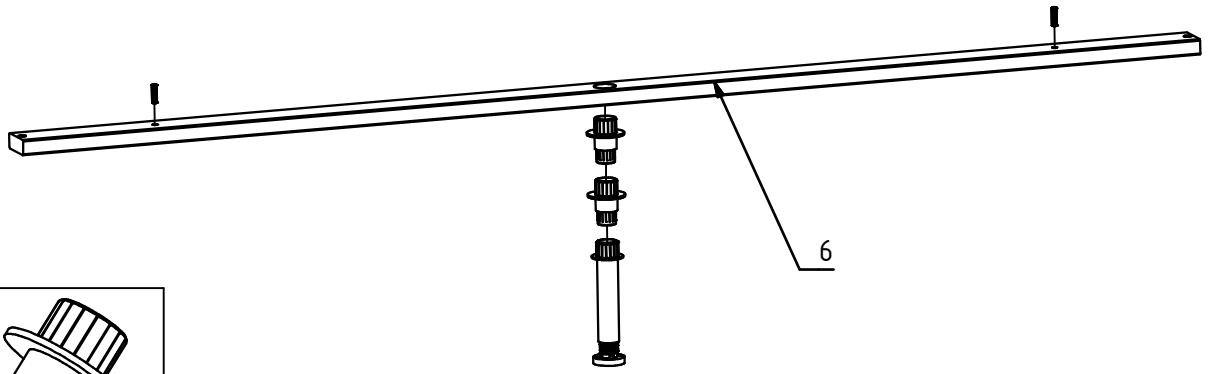
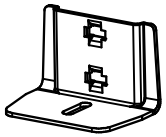
**H**

2x 111 622

M5x30



2x 121 152

M5

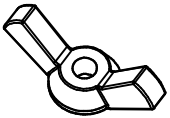

2x 124 560

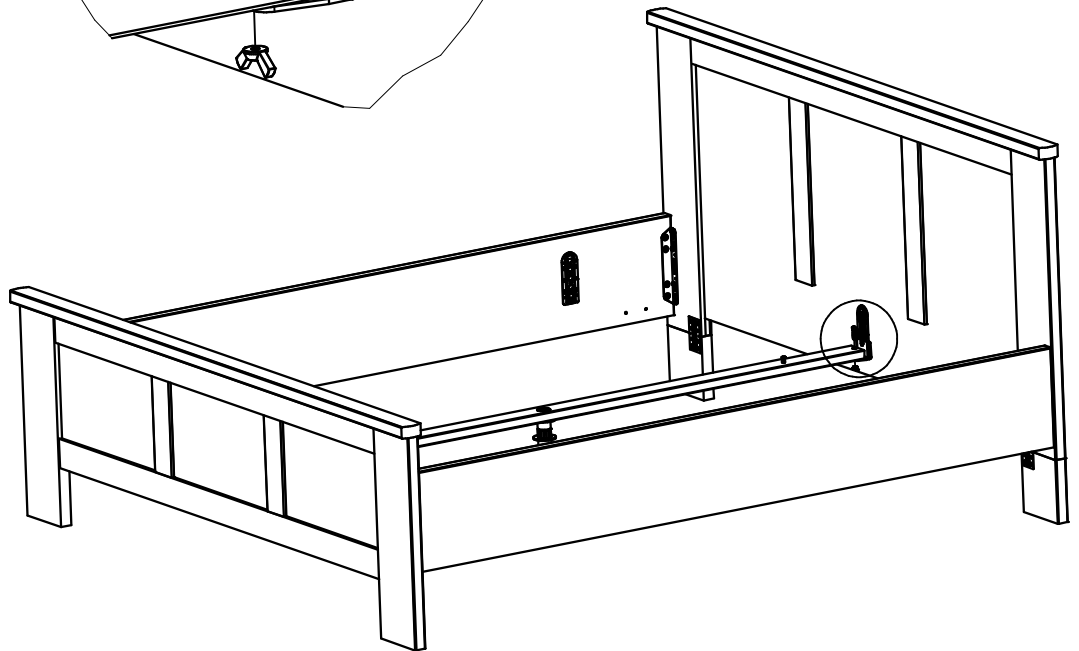
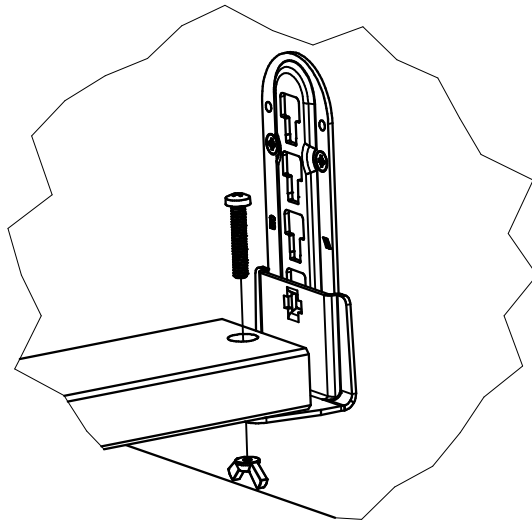

4,0x13



8x

121 359

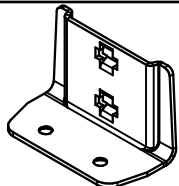

4x

111 627

