



# SEOUL LIFESTYLE TV BED SLEEPMOTION 200i



BEFORE STARTING ASSEMBLY PLEASE REFER TO THE OWNERS MANUAL SUPPLIED WITH YOUR SLEEPMOTION 200i BED BASE AND FOLLOW THE INSTRUCTIONS TAKING NOTE OF ANY SAFETY PRECAUTIONS OR OPERATIONAL SAFETY REQUIREMENTS OF THE INSTALLATION.

BUILD THE BED BASE FIRST USING ONLY THE EIGHT LONGER LEGS 6" (15 cm), SEE STAGE 1.

**IMPORTANT:** PLACE THE BASE IN FINAL POSITION IN THE ROOM OF USE, CONNECT THE POWER AND CHECK THE OPERATION THEN STEP BY STEP FOLLOW THE TV BED ASSEMBLY INSTRUCTIONS BELOW, TO BUILD THE TV BED AROUND THE SLEEPMOTION 200i BED BASE.

**PLEASE NOTE:**

TO CONTROL THE BED VIA AN APP, PLEASE GO TO THE APP STORE OR GOOGLE PLAY AND DOWNLOAD THE 'NAPP BY DREAMS'.

ONCE DOWNLOADED AND REGISTERED 'ADD DEVICE' THEN FOLLOW THE INSTRUCTIONS.

ONCE CONNECTED YOU WILL BE ABLE TO CONTROL THE TV LIFT VIA NAPP BY DREAMS.

OCASSIONALLY, DUE TO ATMOSPHERIC CONDITIONS OR WHEN RE-PLACING THE REMOTE CONTROL, ONE NEEDS TO RE-PAIR THE SYSTEM:

- 1) TURN OFF ALL POWER.
  - 2) PRESS UP OR DOWN SWITCH ON TV BED REMOTE KEEPING IT PRESSED.
  - 3) TURN POWER BACK ON.
- EITHER THE TV BED REMOTE CONTROL OR THE NAPP CAN BE USED TO RAISE OR LOWER THE TV LIFT.

## Parts Identification

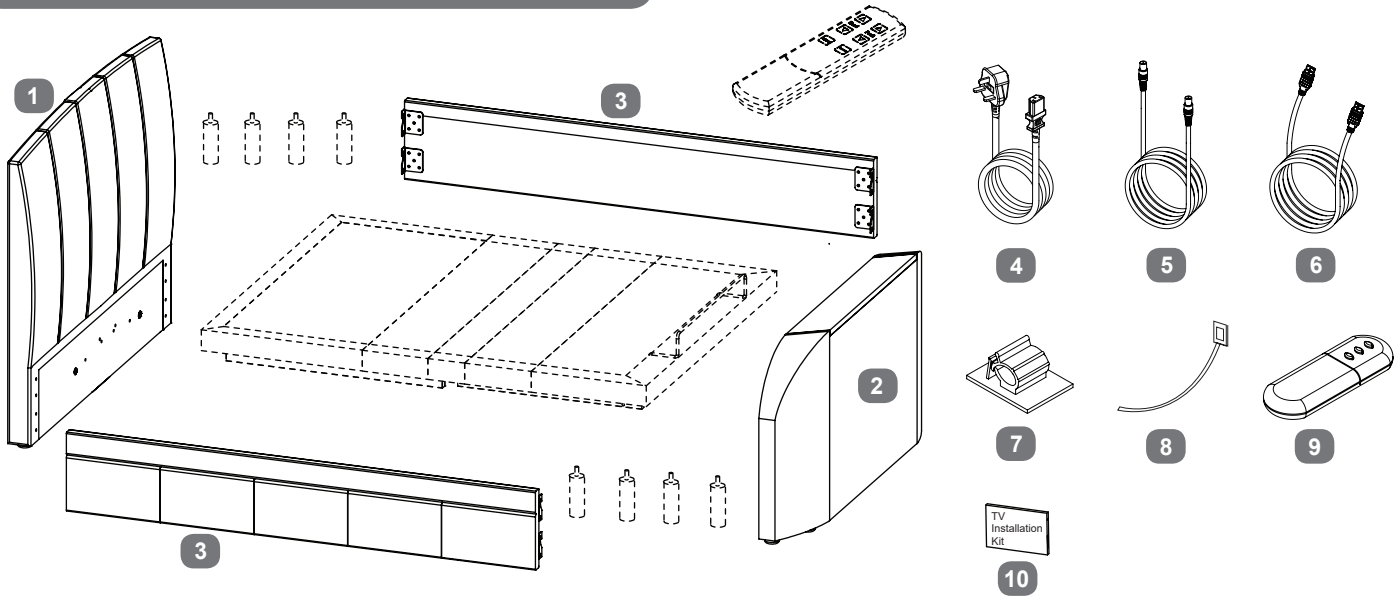

PARTS SHOWN IN DOTTED LINES ARE PACKED IN THE SLEEPMOTION BED BASE CARTON

## Parts Checklist

Ref.	Description	Qty	Ref.	Description	Qty
1	Headboard	1	4	Mains Power Lead - 3 mt	1
2	Footboard	1	5	Aerial Lead - 4 mt	1
3	Side Rails	2	6	HDMI Lead - 5 mt	1
			7	Cable Clips	5
			8	Cable Ties	5
			9	TV Lift Remote Control	1
			10	TV Installation Kit	1

Pack Inside  
accessory  
box in  
footboard  
Pack 2

## Fittings Checklist

### HARDWARE NEEDED FOR FIXING SIDE RAILS TO HEADBOARD & FOOTBOARD PACKED IN SIDE RAIL PACK 3 - HARDWARE PACK (A)

Ref	Description	Qty	Ref.	Description	Qty
A	Bolts (M8x30mm) for fitting side rails (3&4) to headboard & footboard (1&2)	x16	C	Flat Washers (for M8 bolts)	x16
B	Spring Washers (for M8 bolts)	x16	D	Allen Key (for M8 bolt)	x1

### Additional Tools Required

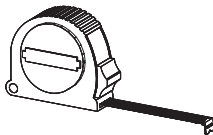

Tape Measure

### Care & Maintenance

In the unlikely event of missing or damaged parts, please contact the customer service team on 0344 292 00 00. When calling this number, please quote the part code reference numbers shown in this leaflet when requesting spare or replacement parts.

### General Hints & Tips



Please retain your assembly instruction and tools provided for future use. Periodically check that all bolts are still tight.



Assembly requires two persons.



1.5 HRS

Approximate time to assemble this product



When they are supplied and are part of the assembly of this bed, ensure that the barrel nuts are fitted the correct way so the hole in the nut is facing towards the intersecting hole in the panel.

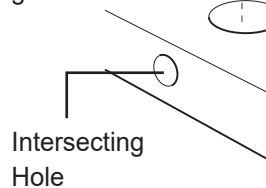

We recommend the bed is assembled in the room it shall be located in.

### Screw in the Legs and put Bed Base in the position in which it will be used

Stage

1

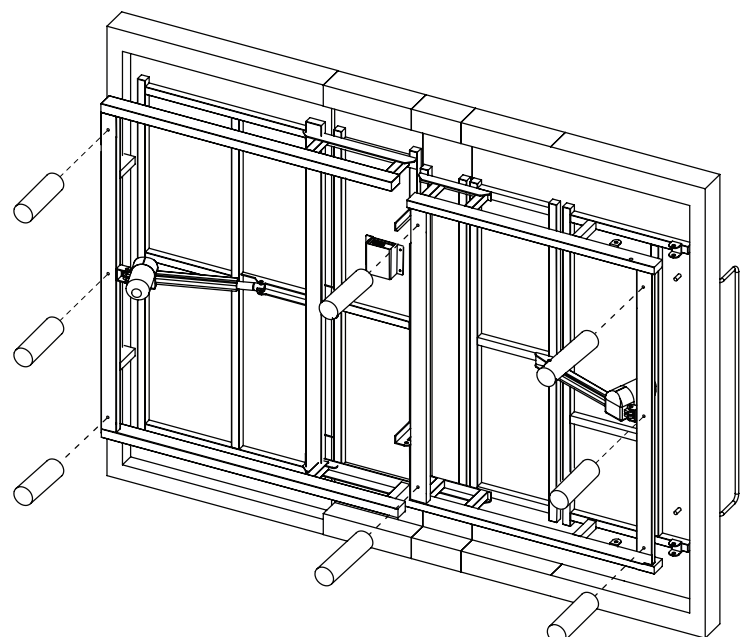
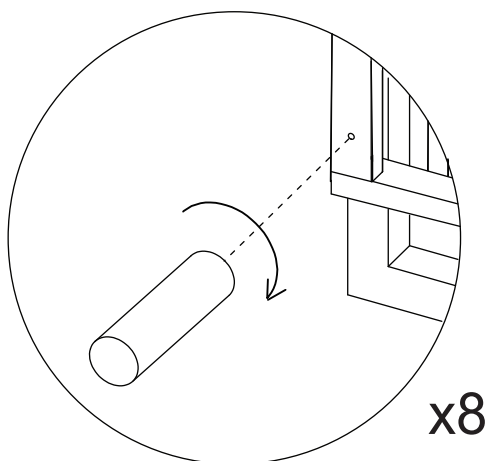

# Prepare the Head & Foot Ends for assembly

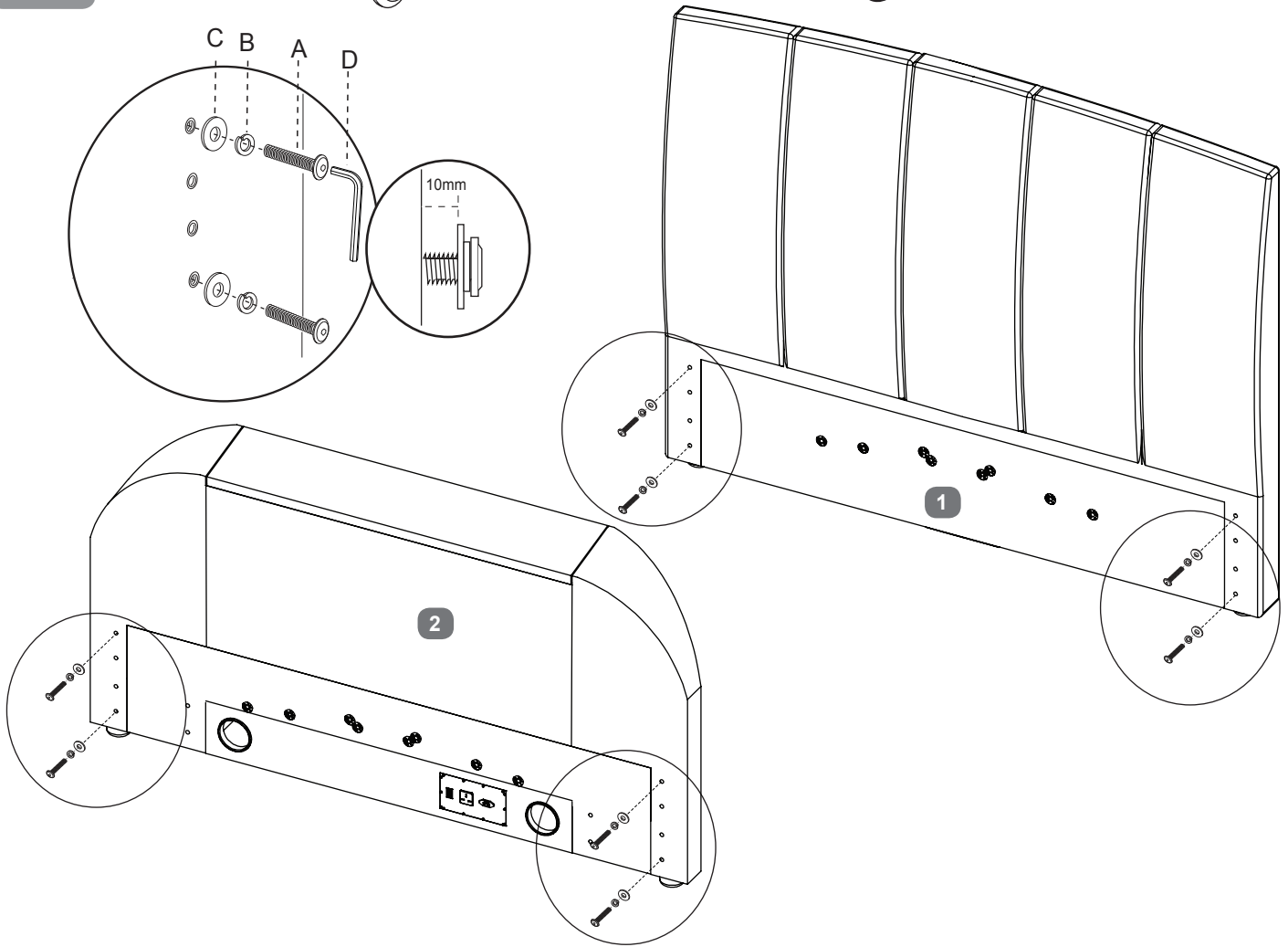

Stage 2

- A  x8
- B  x8
- C  x8
- D  x1

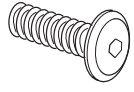

# Assemble Head End and one Side Rail using hardware Pack 'A'

Stage 3

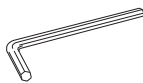
- A  x4
- B  x4
- C  x4
- D  x1

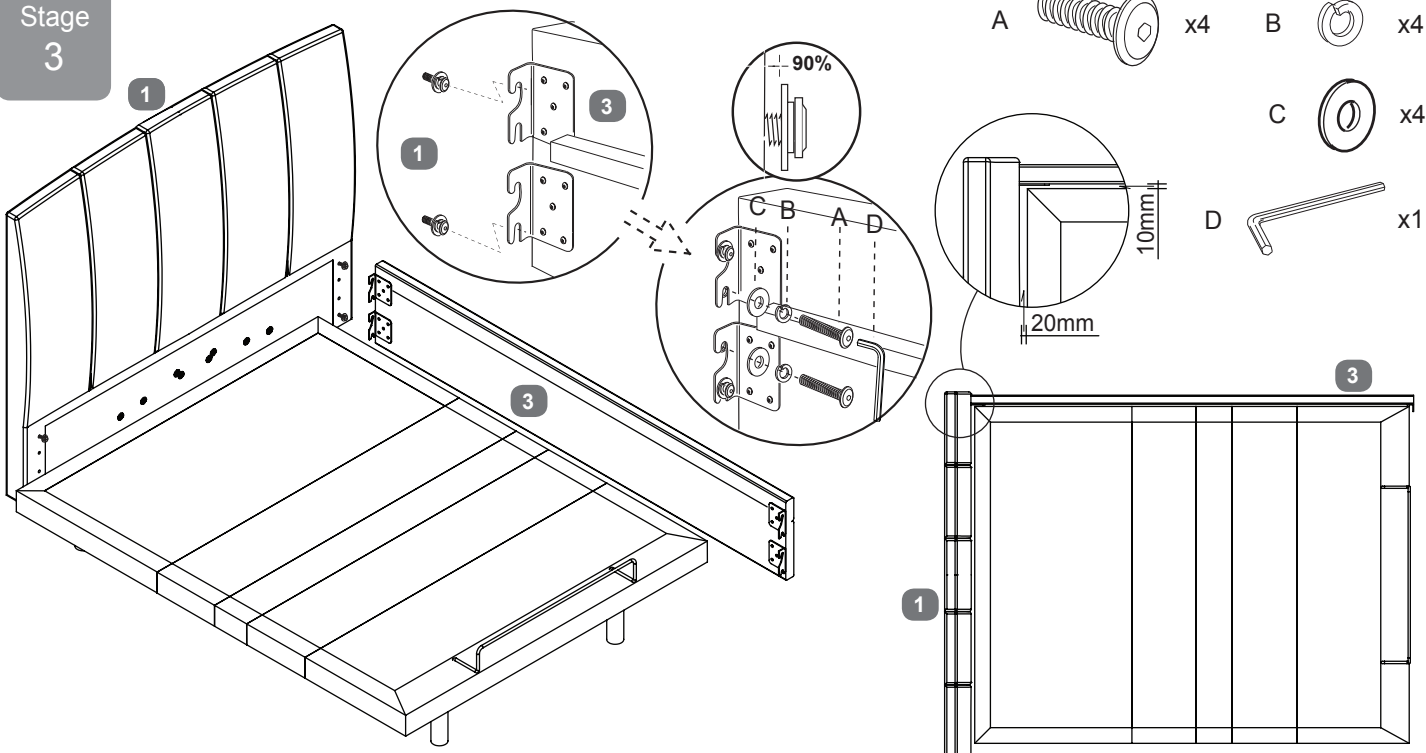

## Raise the Head and Foot Ends of the Bed Base

Stage  
4

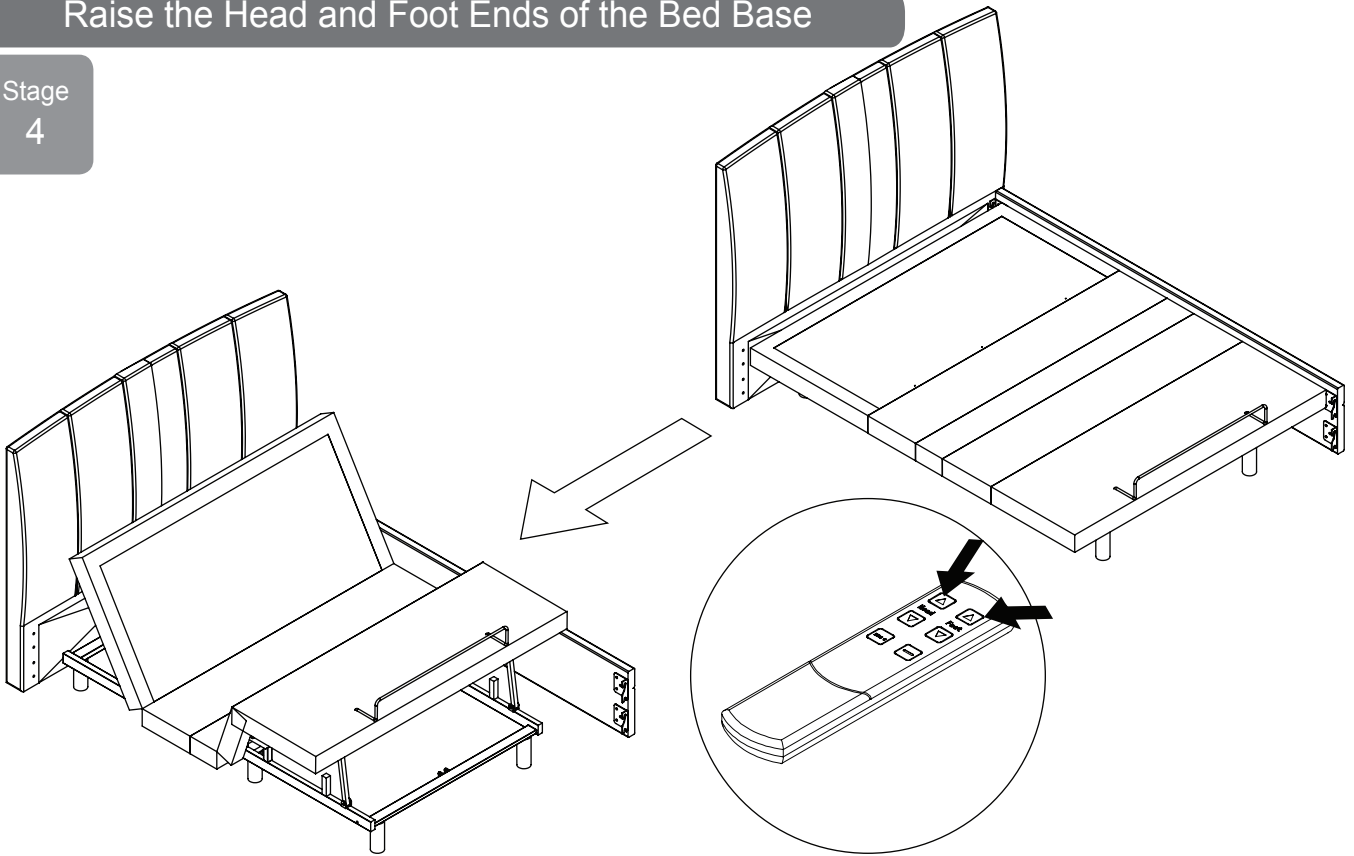

## Position Foot End and connect Side Rail brackets..

Stage  
5

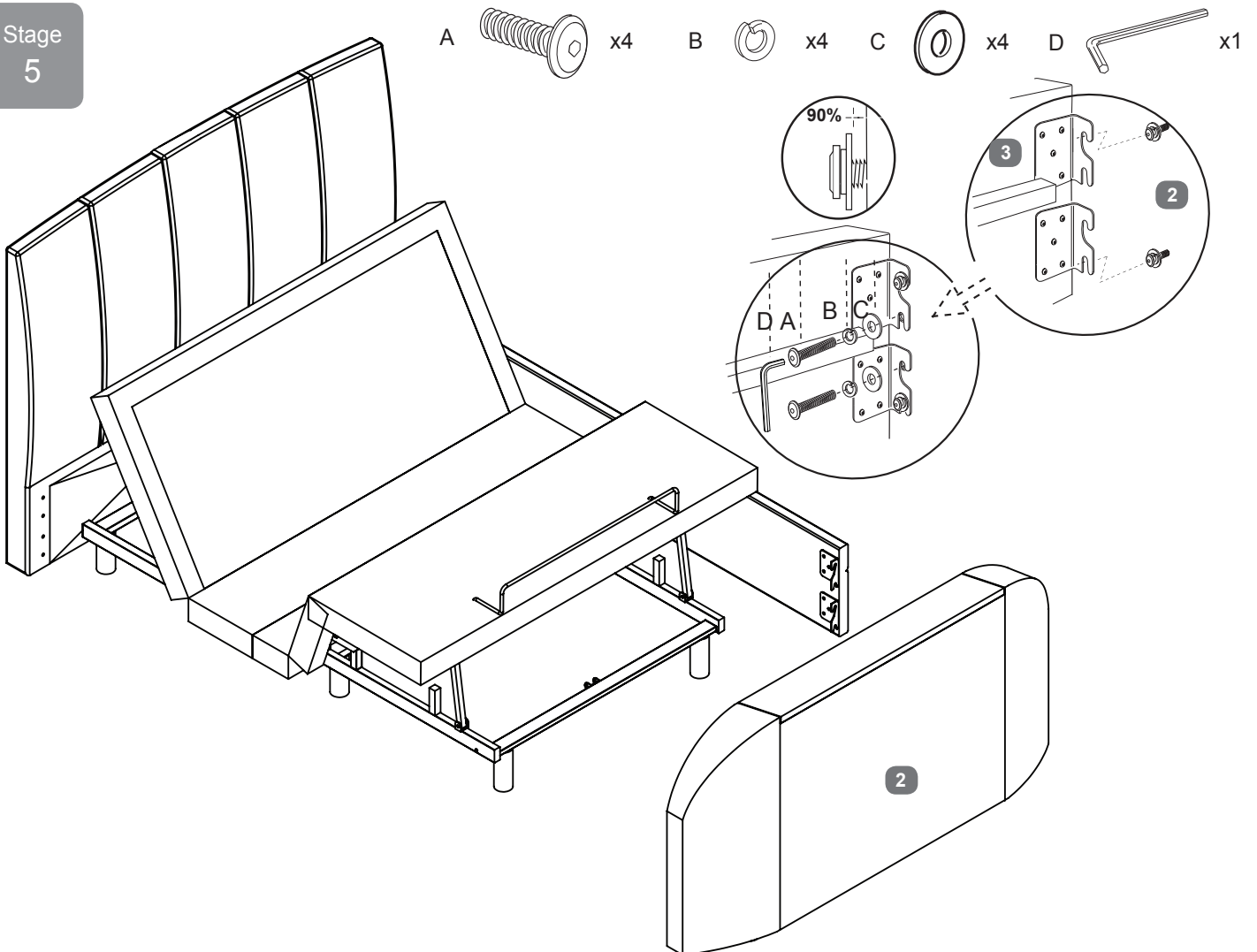

## Electrical & Cable Connections

### Stage 6

Connect Main Power Lead (4) to your wall socket - for safety this must be an earthed power supply.

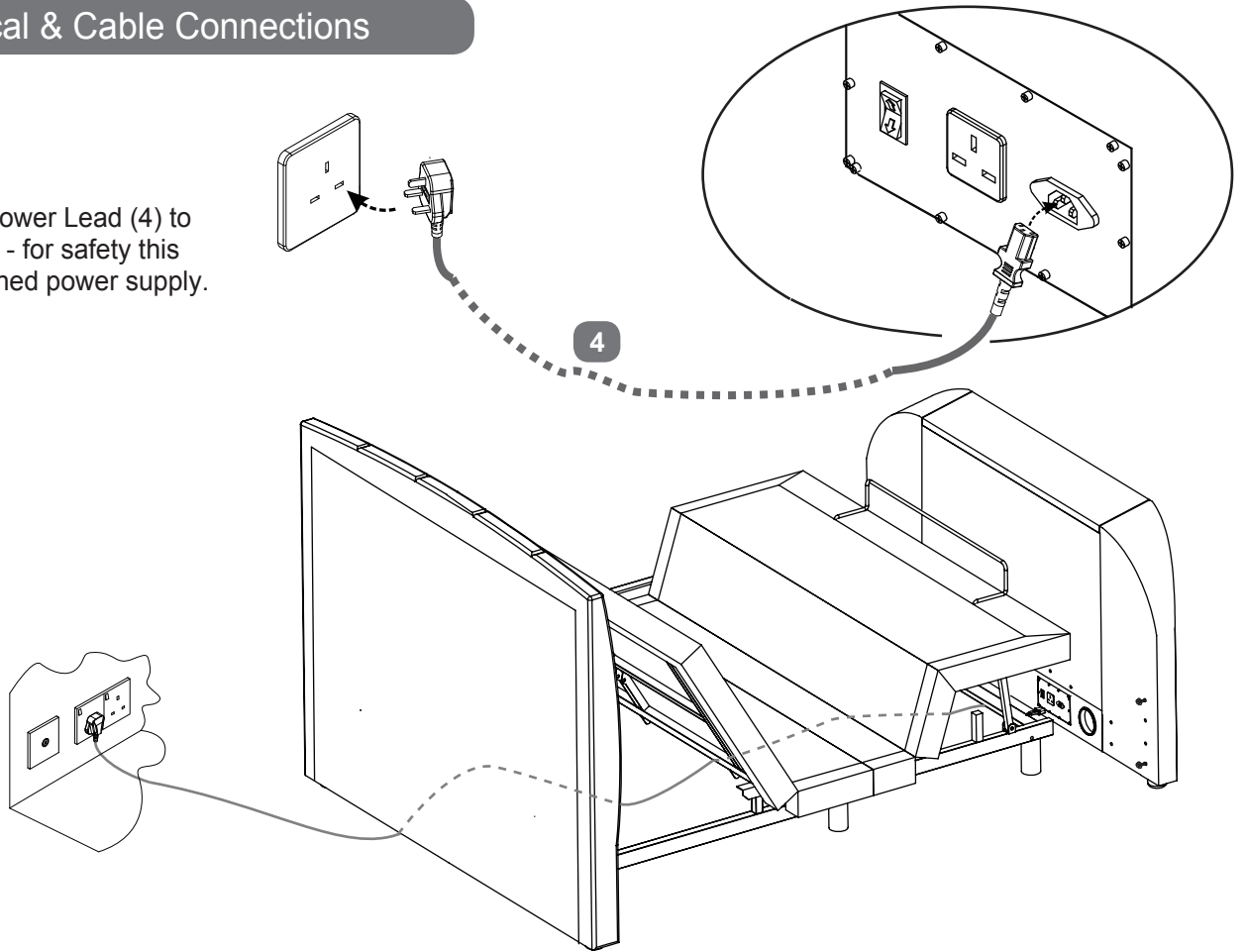

### Stage 7

Press the "UP" button to raise the TV lift.

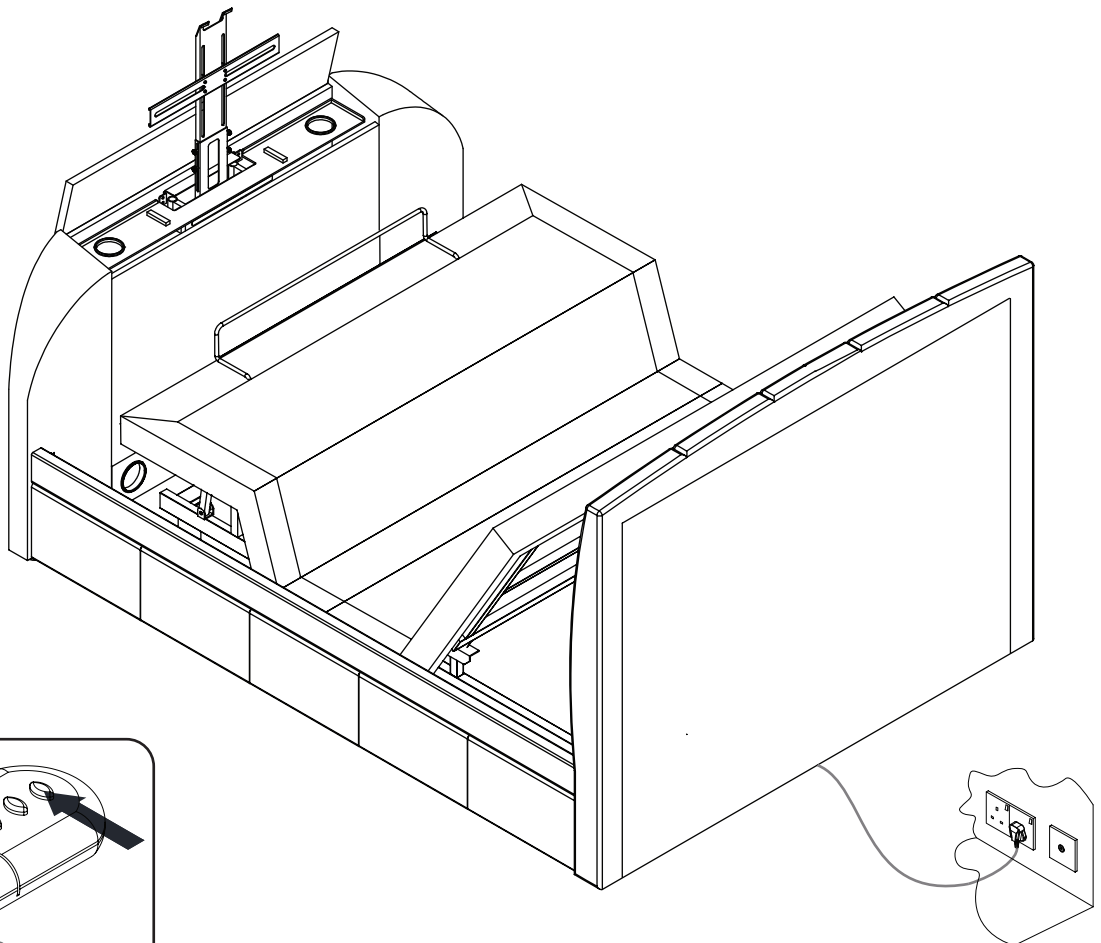
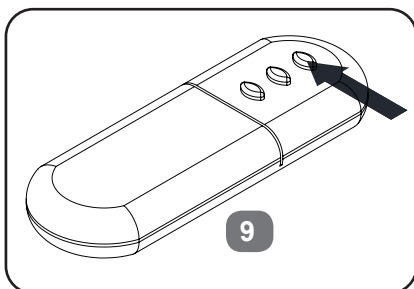

**TIP:**

BEFORE FITTING THE TV,  
PUSH CABLES THROUGH  
EACH DUCT FROM THE TOP.  
CHOOSE THE BEST SIDE TO  
USE DEPENDING ON WHERE  
THE CONNECTION PORTS  
ARE ON BACK OF YOUR TV.  
NEVER CROSS CABLES FROM  
ONE SIDE TO THE OTHER.

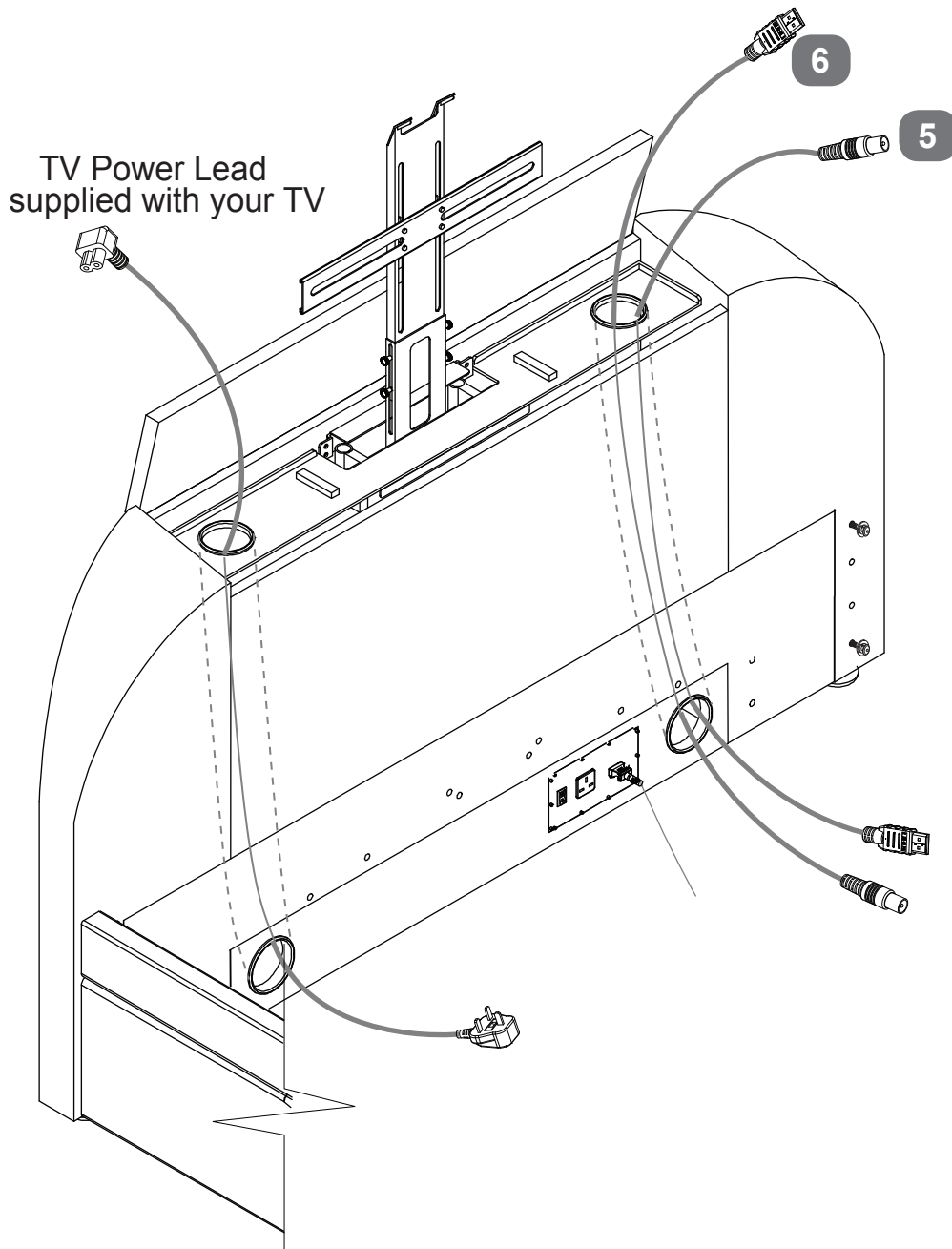

# TV Installation - Normal Vesa Fixing

Stage  
9

IF SCREWS ARE SUPPLIED WITH TV, PLEASE USE THOSE IN PREFERENCE

a x2 Screw-Washer sets (M8x25mm) Use 5mm Allen Key (D)

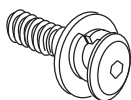

Counter-Sunk Screws (M6x12mm)

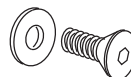

Counter-Sunk Screws (M4x12mm)

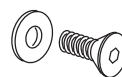

b x2 Allen Key (4mm)

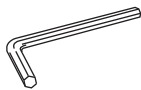

Allen Key (2.5mm)

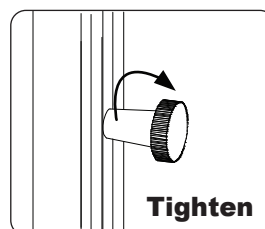
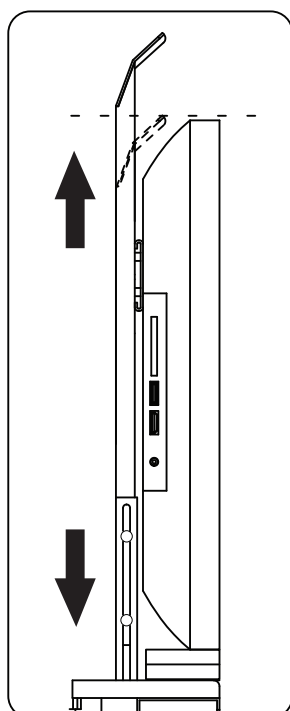
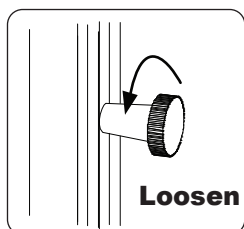
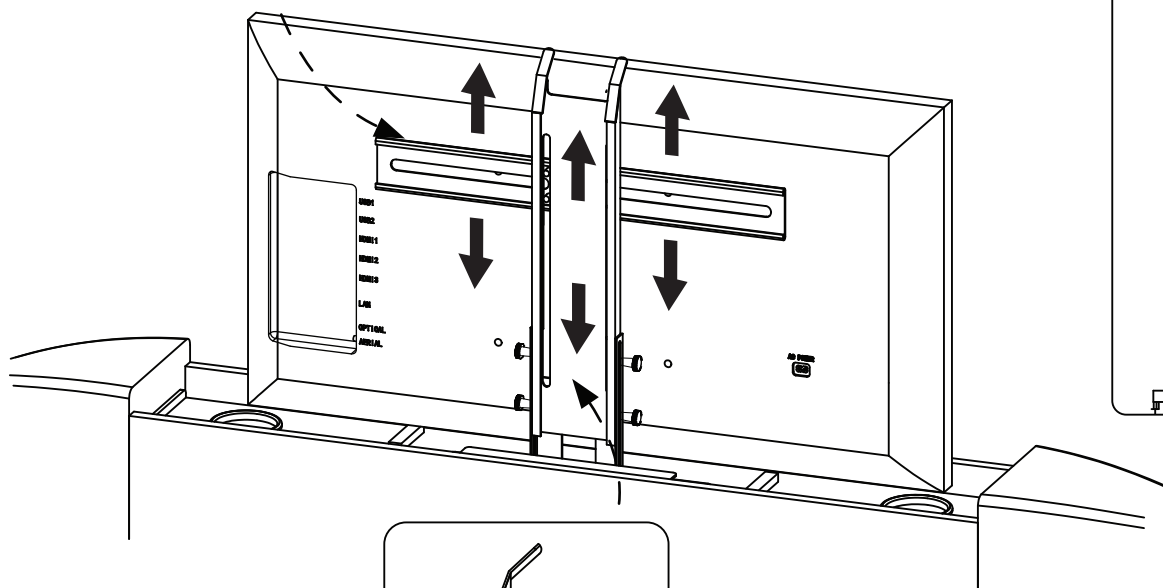
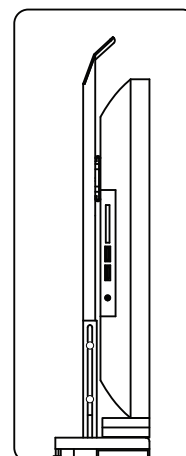
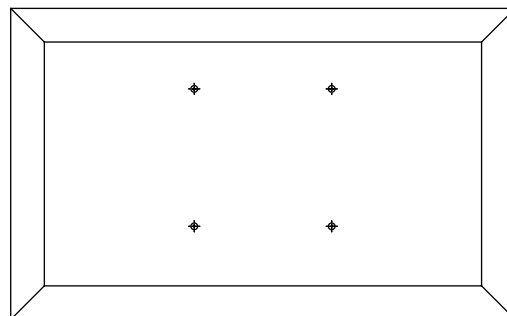
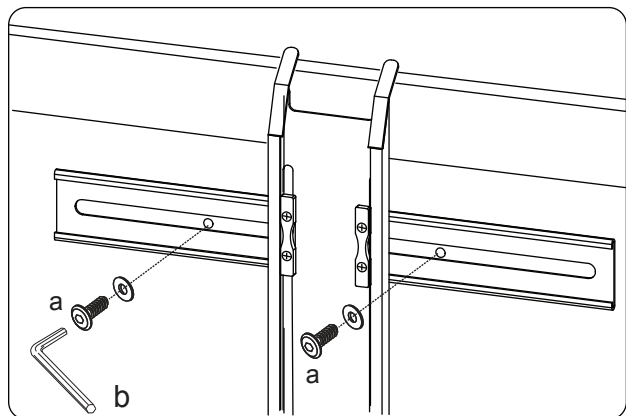
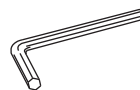

# TV Installation - Vesa 100x100

Stage  
10a

REMOVE CROSS-BRACKET  
AND FIX DIRECTLY TO BACK OF TV

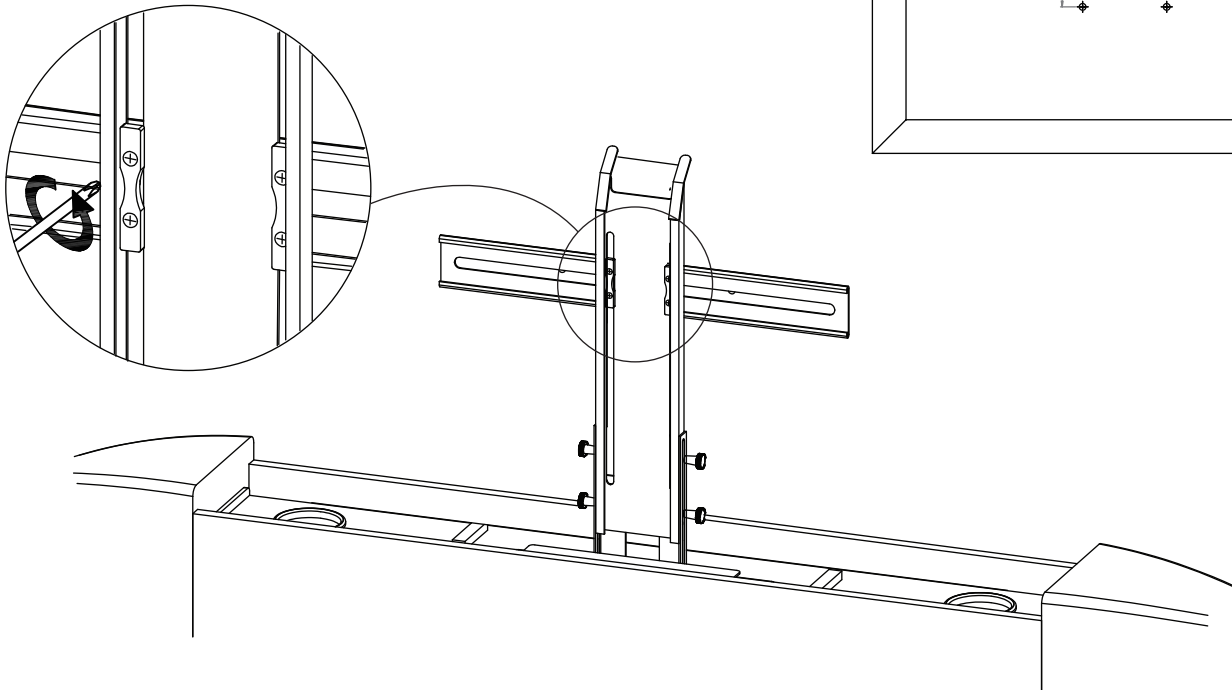
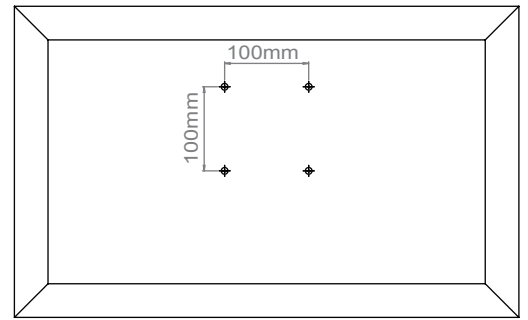

Stage  
10b

IF SCREWS ARE SUPPLIED WITH TV, PLEASE USE THOSE IN PREFERENCE

a x2  
Screw-Washer sets  
(M8x25mm) Use  
5mm Allen Key (D)

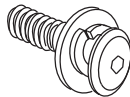

Counter-Sunk Screws  
(M6x12mm)

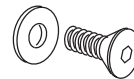

Counter-Sunk  
Screws (M4x12mm)

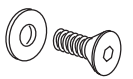

b x2  
Allen Key (4mm)

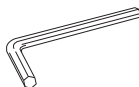

Allen Key (2.5mm)

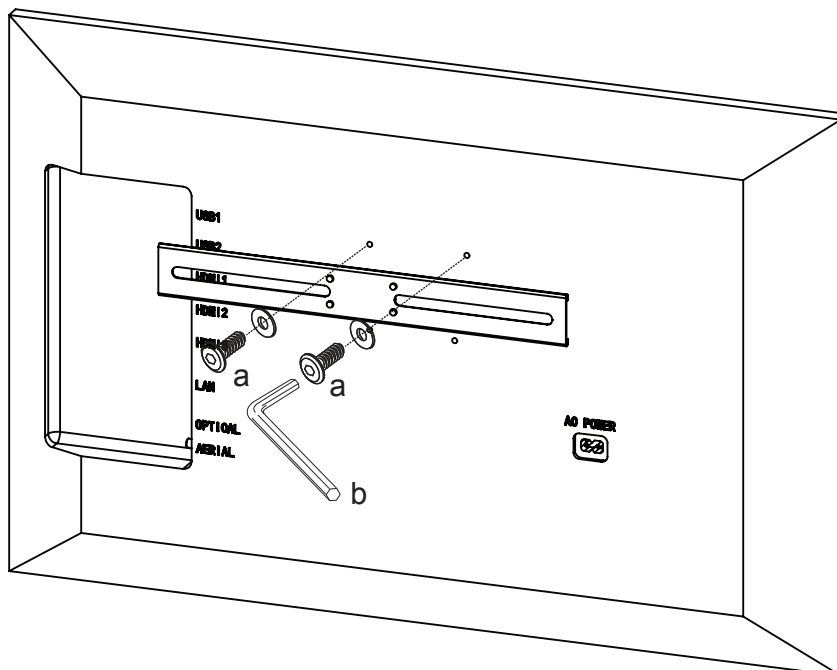
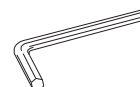



Stage  
10c

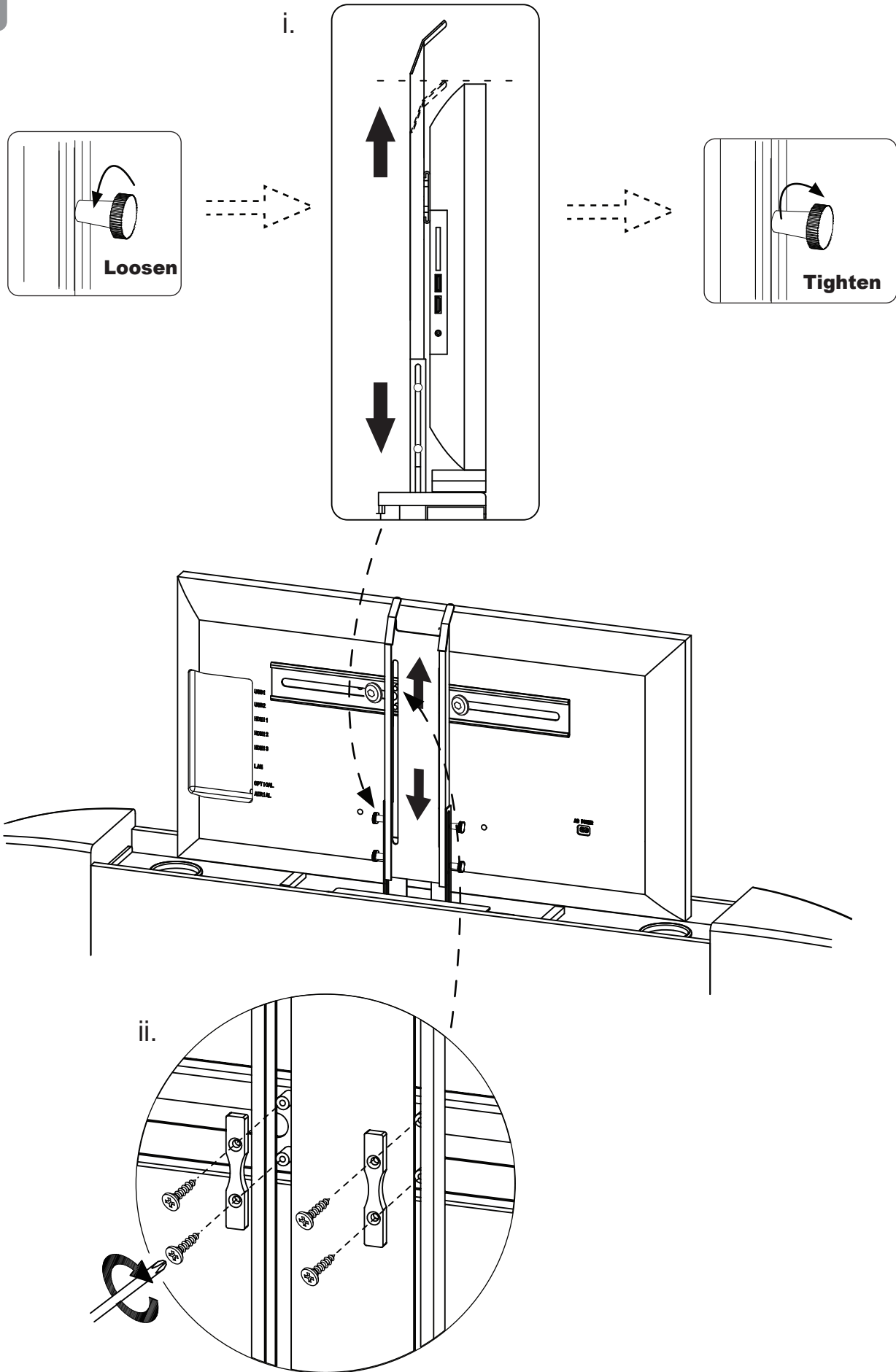

# Electrical & Cable Connections

Stage  
11

**Note: For illustration purposes only, TV connections may vary.**

TV Power Lead  
supplied with your TV

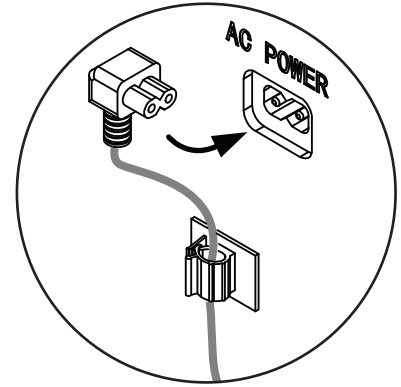

Keep wires tight - peel off cover from cable clips & adhere to back of TV.

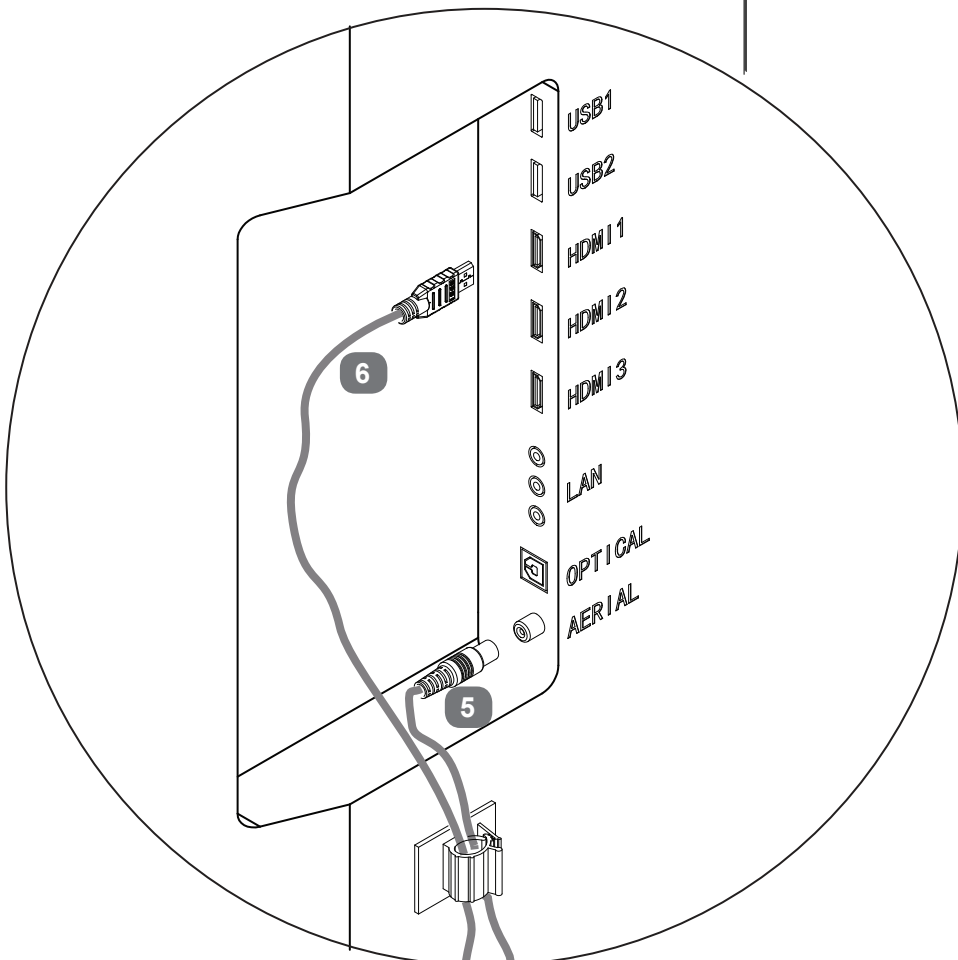
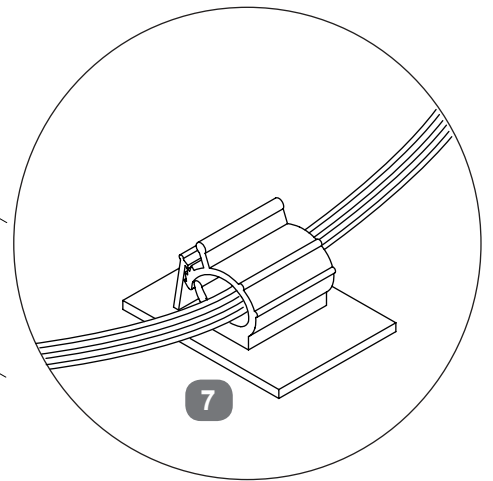

**PLUG IN - KEEP ALL CABLES TIGHT - USE CLIPS & TIES PROVIDED.**

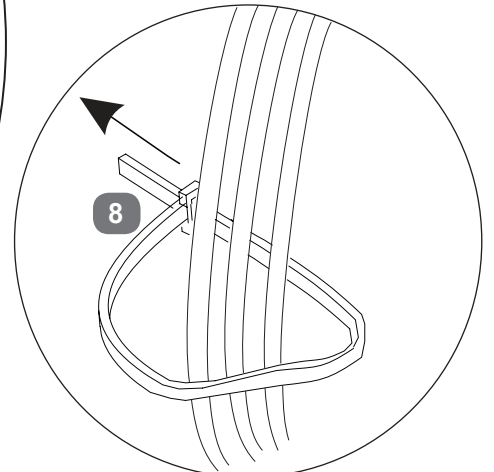

# Electrical & Cable Connections

Stage  
12

Press the "DOWN"  
button to lower the  
TV lift.

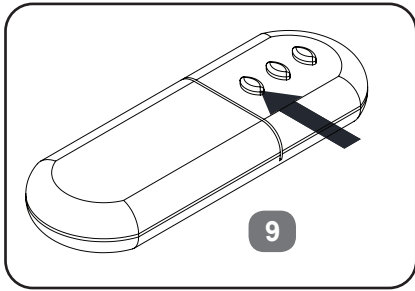

TV Power Lead  
supplied with your TV

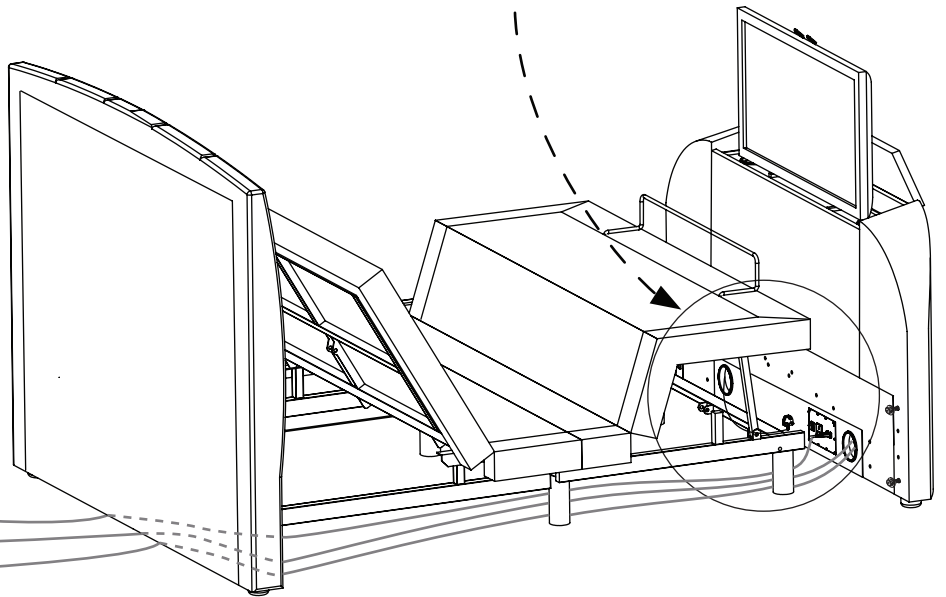
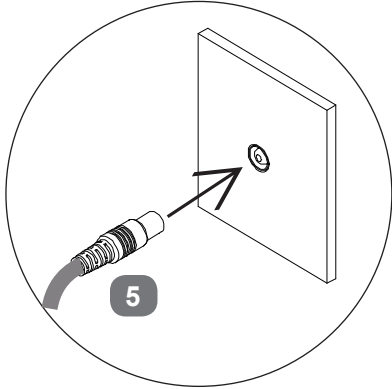
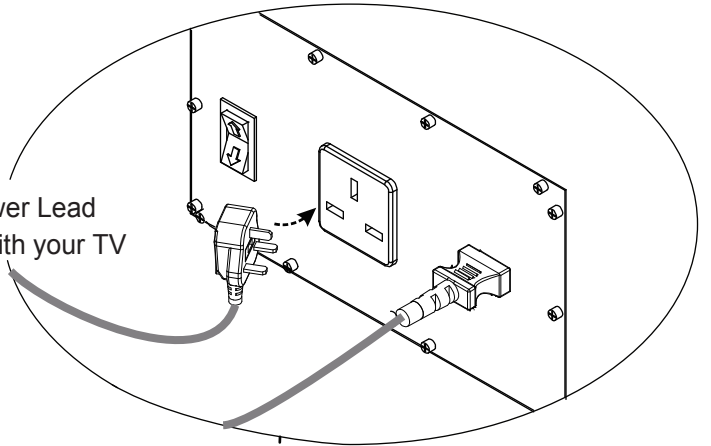

6

Stage  
13

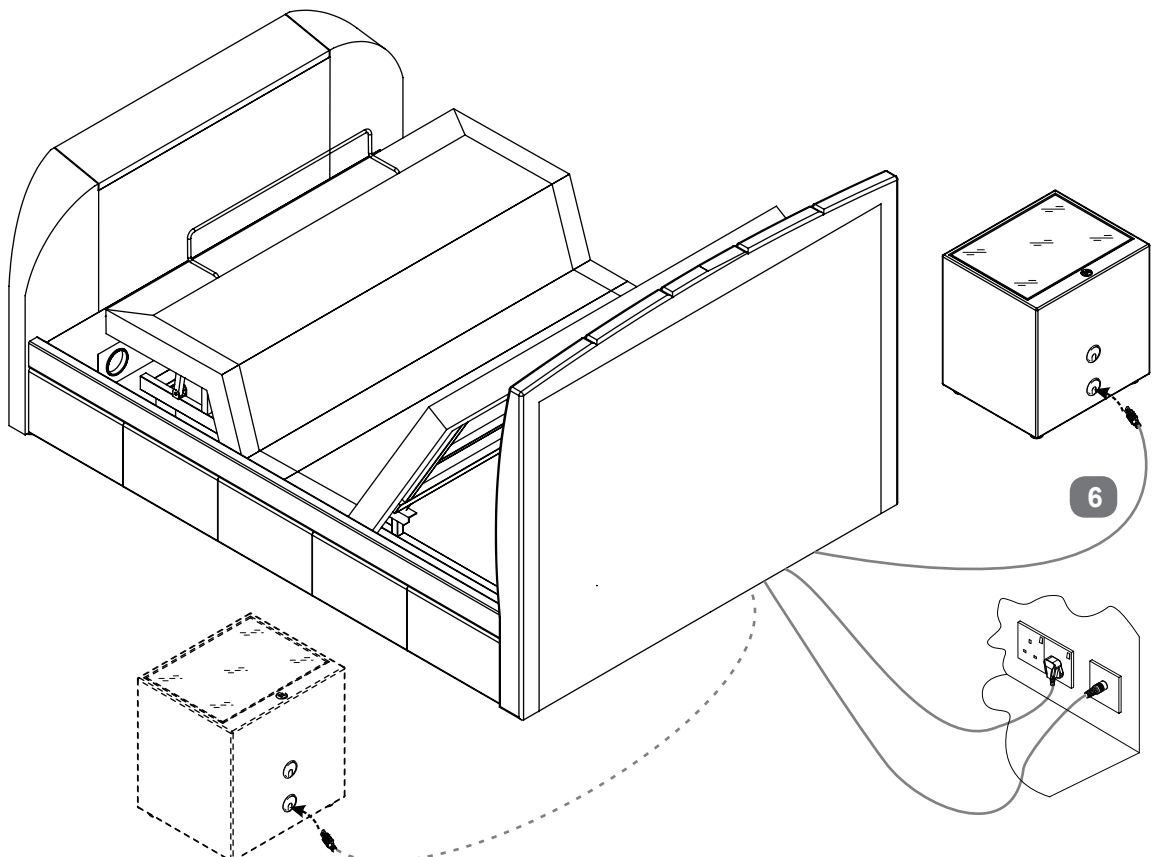

6

Make sure everything is working properly then fit second Side Rail (3)

Stage  
14

- A  x4    B  x4    C  x4    D  x1

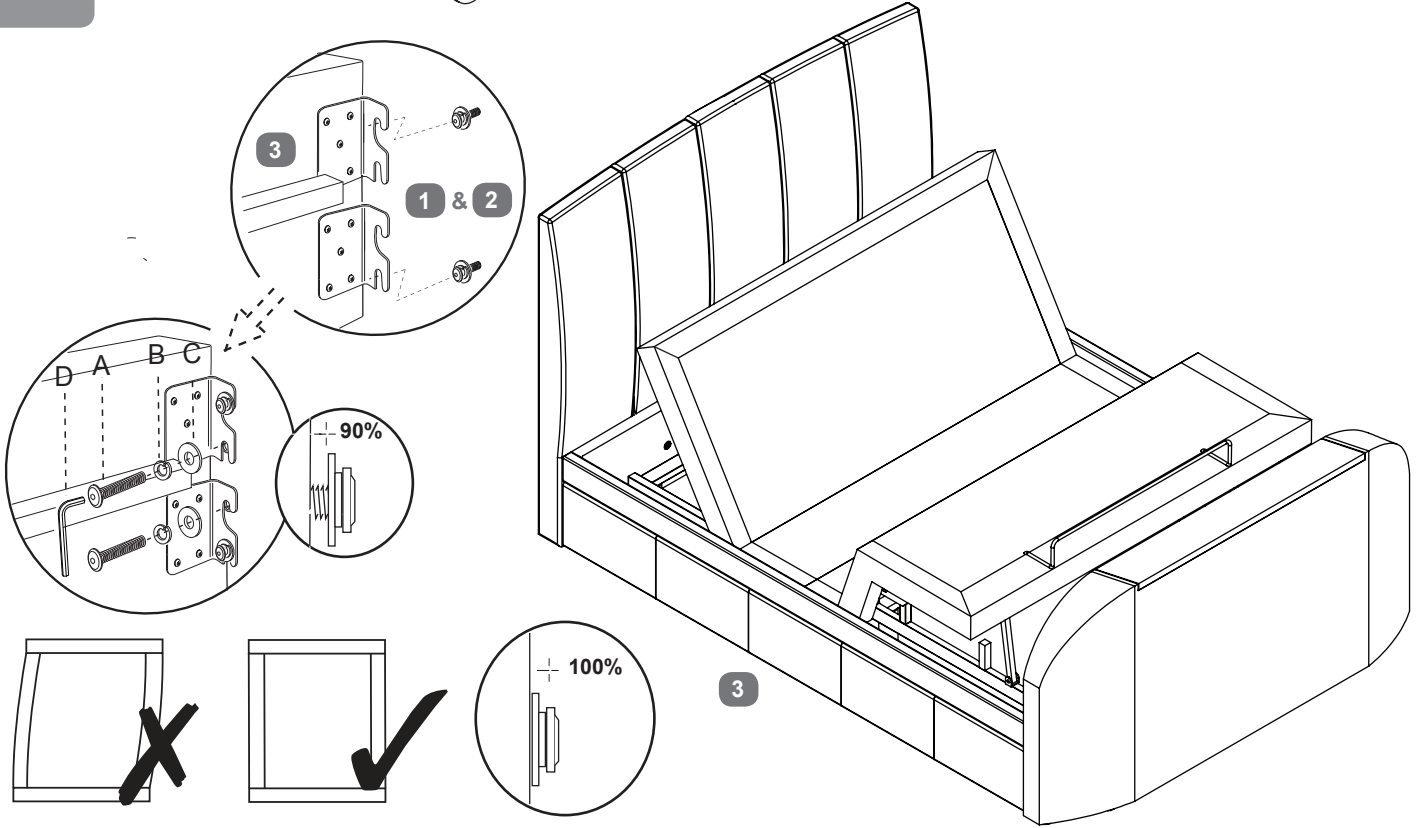

Stage  
15

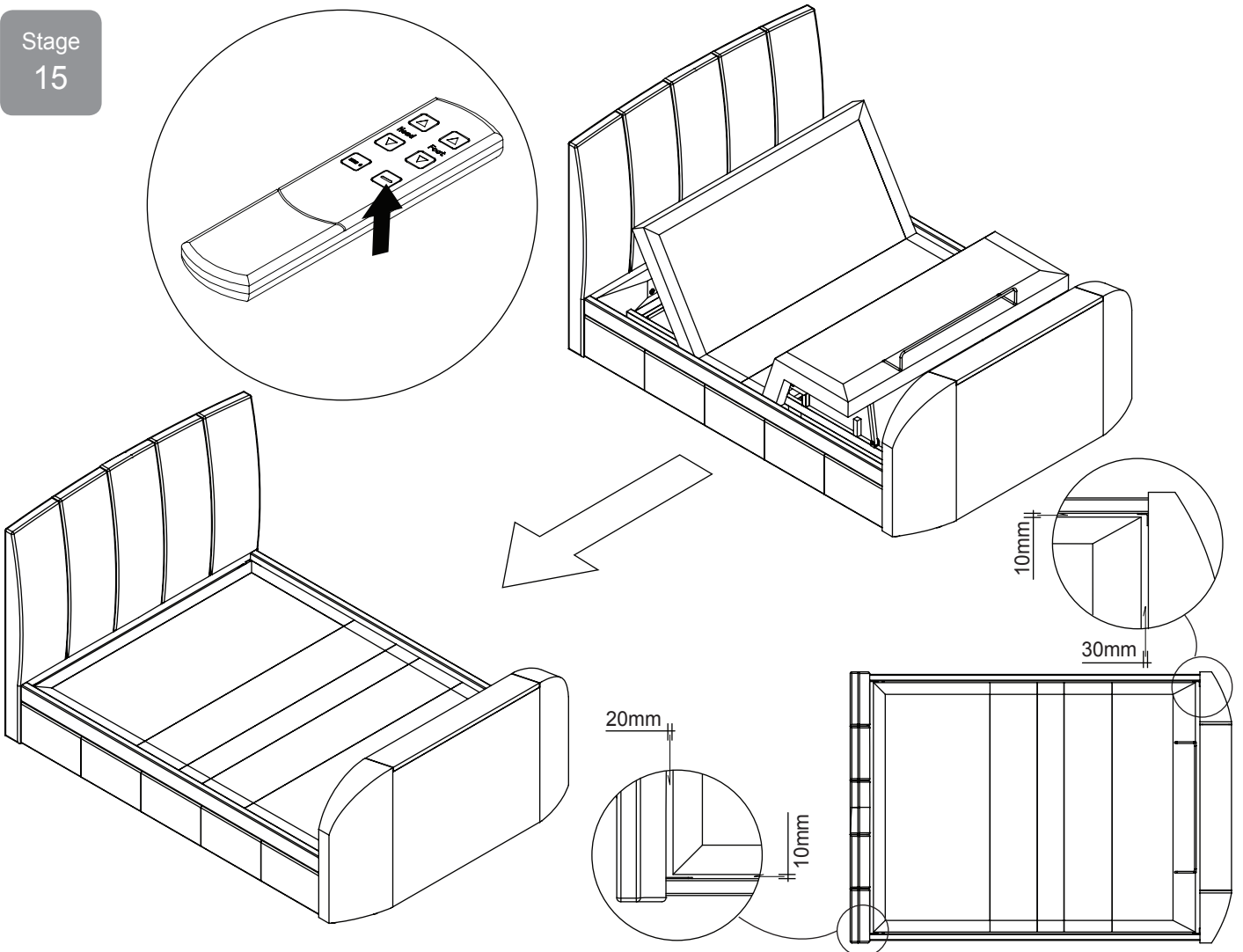



## GENERAL INFORMATION

It is very important not to place any vessel containing liquids, e.g. drinks or vase of flowers, on top of the TV footboard which may accidentally spill and enter the TV compartment as this could cause damage to the TV and/or the TV lifting equipment.

If this happens, please contact Customer Services - ring 0344 292 00 00.

Do not expose the bed to an undue level of heat - keep away from radiators.

Never allow anyone to sit on the foot end of the bed - keep children well away from moving parts.

To keep the bed clean, we recommend that it be wiped over with a slightly dampened cloth or if fabric use a light vacuum cleaner; disconnect power before cleaning.

Supplied with the TV bed is a remote control to operate the TV Lift and when you fit your own TV there is a remote control to operate that as well. Both these remotes use batteries - there may be batteries in the Sleepmotion remote control too, please check the user guide supplied with the bed.

There are strict controls for disposal of batteries - your local council can advise on how to safely dispose of them.

Never burn batteries on an open fire as they could explode.

## IMPORTANT POWER INFORMATION

It is essential that the Mains Power Lead (4) is connected to an earthed socket be it a wall socket or extension lead - otherwise there is risk of damage or even electric-shock.

The socket providing the power must be accessible at all times in case you need to switch off the power quickly.

During an electrical or lightening storm - disconnect the power completely as a precaution.

Always un-plug the power when going on holiday or when the bed is not used for an extended period.

If you have young children in the home always disconnect the power at the wall socket for extra safety.

Power outlets, extension leads or adapters must not be overloaded beyond their limit - this can result in fire or electric shock. Leads supplied with this bed, or other approved mains powered extension leads used to power the equipment, must not be placed where they can be walked on - this is dangerous and could lead to accidents.

Do not interfere with or modify any cables already fitted and do not add any extra media leads unless they are routed through the ducts as shown in Stage 8. All leads must be tightly connected to back of TV, never hanging loose.

Never touch moving parts or any part of the equipment - if something needs to be checked, disconnect the power first.

Do not insert anything into the footboard as this could seriously damage the TV and/or the TV lifting equipment and could, if done carelessly, cause serious damage or injury.

If the equipment doesn't operate normally or if there is an unusual noise, disconnect the power.

**IMPORTANT:** Care should be taken when connecting electrical items. If you are in any doubt about the connections please consult an approved electrician.

## TELEVISION INSTALLATION

Please follow the television installation instructions below.

Raise the TV Lift by pressing the Top button of the remote control.

Connect the Aerial & HDMI cable (5&6) by passing down the appropriate duct - see Stage 8.

Connect the TV to the mounting bracket as in Stage 9 or 10, as appropriate.

If necessary mounting bracket can easily be adjusted up or down to align with upper fixing holes on rear of TV.

Connect the TV Power Lead (supplied with TV) by passing plug down one of the ducts, plugging it into the adapter then into the TV power socket which is on the face of footboard - see Stage 12. This socket is only to be used for the TV as the supply is not constant.

If required, connect your own media cables through either of the ducts - connect your media equipment when ready.

Please use the cable clips & cable ties to make certain there are no loose wires to snag

The TV can now be operated following the TV Operation Guide supplied with your TV.

When finished viewing, lower the TV back into the footboard by pressing Down button of the remote control.

The TV will retract into the footboard automatically - power shall be turned off when TV reaches the bottom.

When the Up button is pressed - the TV Lifting Column rises and power to the TV turns back on automatically.

## TROUBLE SHOOTING

If your equipment does not operate please check all the power connections to the wall and to the socket in the footboard.

Make sure TV is switched on. (Note: TV will only work when it is in the up position).

If you cannot resolve an issue or still have a problem or need help, please contact Customer Services for advice.