



CARE OF YOUR GALLWAY SOFA BED

Do not discard any of the packaging until you have checked the product.

Outlined below are General Care Instructions that will help prolong the look and life of your sofa bed by preventing wear and damage.

**PLEASE NOTE: The Fabric on this product is Flame Retardant treated and therefore should be Specialist Upholstery cleaned only
Please note this product is designed for occasional overnight use only**

CLEAN REGULARLY:

- ✚ Remove dust by pre-brushing with a soft brush
- ✚ Gently Vacuum all areas

SUNLIGHT AND HEAT

- ✚ Direct sunlight or heat can cause fabrics to deteriorate or fade. Protect them by situating your furniture out of the way of prolonged direct sunlight or by drawing curtains and blinds when applicable.
- ✚ Avoid placing furniture too close to fires or radiators.
- ✚ Reduce potential damage by moving items around or changing position so that the same piece or area is not always exposed.

SAFETY WARNINGS



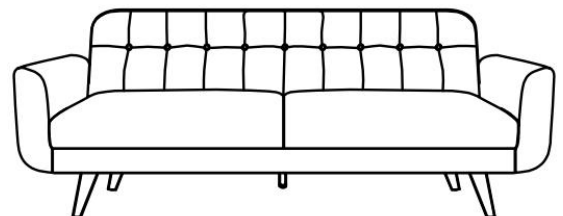

✚ **ENTRAPMENT WARNING: KEEP HANDS CLEAR WHEN ADJUSTING THE RATCHET MECHANISM TO AVOID FINGER ENTRAPMENT: DO NOT ALLOW CHILDREN TO ADJUST THE MECHANISM.**

- ✚ Never allow children to jump on the Sofa bed.
- ✚ Do not allow domestic pets to climb on the sofa bed or chew or claw it; oils and greases from animals will cause deterioration in the appearance of the fabric.
- ✚ Sharp objects such as buckles, toys and jewellery can easily snag on the fabric and produce tears and pulls in the fabric.
- ✚ Hot objects such as the heat from cups and mugs can permanently disfigure upholstery.



INSTRUCTIONS FOR FIXING LEGS TO GALLWAY SOFA BED

Parts List:

A		Armrest x 2	D		Bolts x 16
B		Legs x 4	E		Allen key x 1
C		Support leg x 1			



Please note that the legs of sofa (Part B and C) are put in with the two sides of “hidden” legs zipped into the back of the sofa. As per below shown:

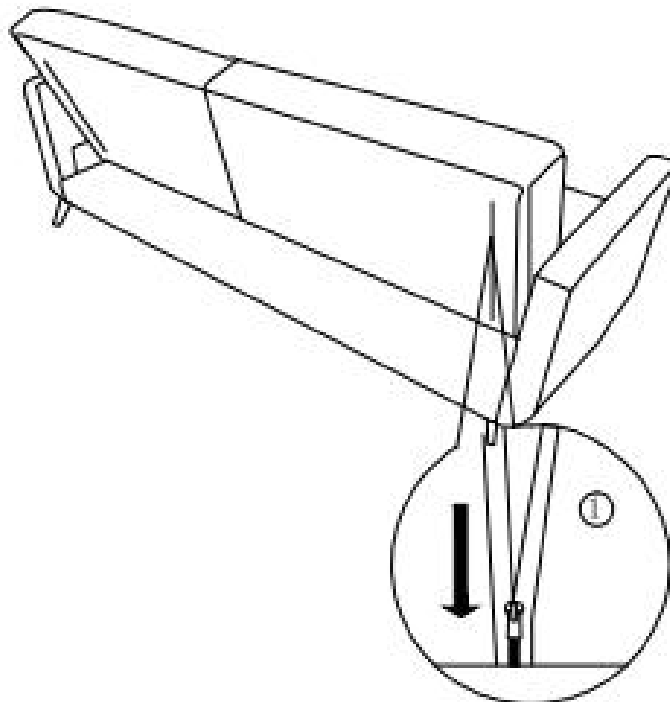

1) Unpack sofa bed and check the above items are present. If you have any parts missing contact Kyoto Futons Ltd (01778) 380555. sales@kyoto.co.uk

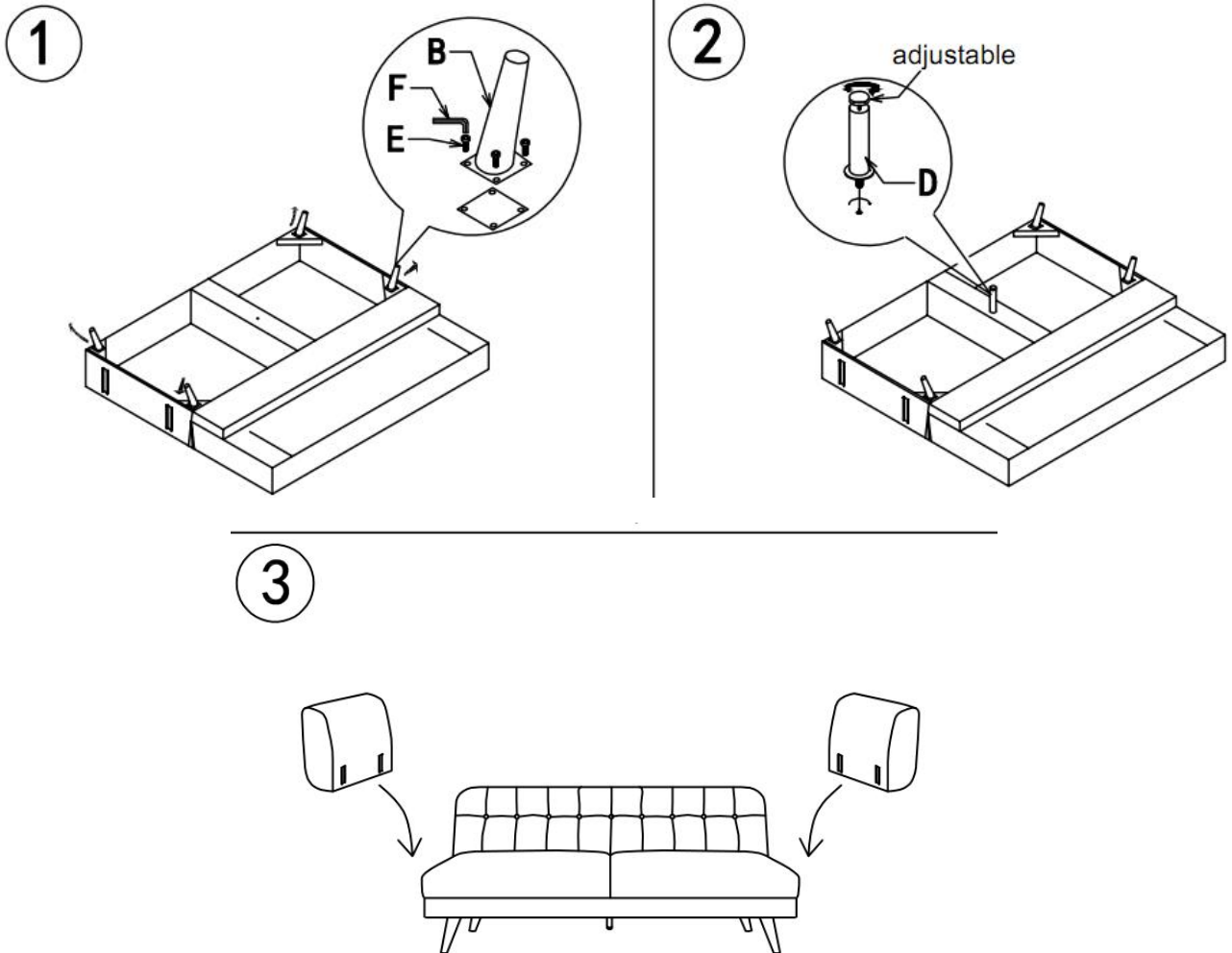

2) Place the sofa bed face down on a clean, flat surface.

3) Affix the legs as shown in the above diagram using the bolts and allen key supplied. Turn the sofa bed over and place on the legs. And the armrests should slot into place using the fixings already there.

Sofa Bed “Hidden” Legs

Please note there are “hidden” legs zipped into the back of the sofa bed to be used when in the bed position:

1) Draw the legs from the zipper pockets before converting from a sofa to the bed position.

Follow the instructions below to convert the sofa to the bed position.

2) To retract the legs: first convert from the bed position to the sofa (following the instructions below).

Retract the legs by pressing firmly on the button at the top of the leg (this will release the lock) and press toward the bed; zip close once retracted.

WARNING: TAKE CARE NOT TO TRAP YOUR FINGER WHEN CARRYING OUT THE ABOVE. DO NOT ALLOW CHILDREN TO PLAY WITH OR RETRACT THE LEGS.

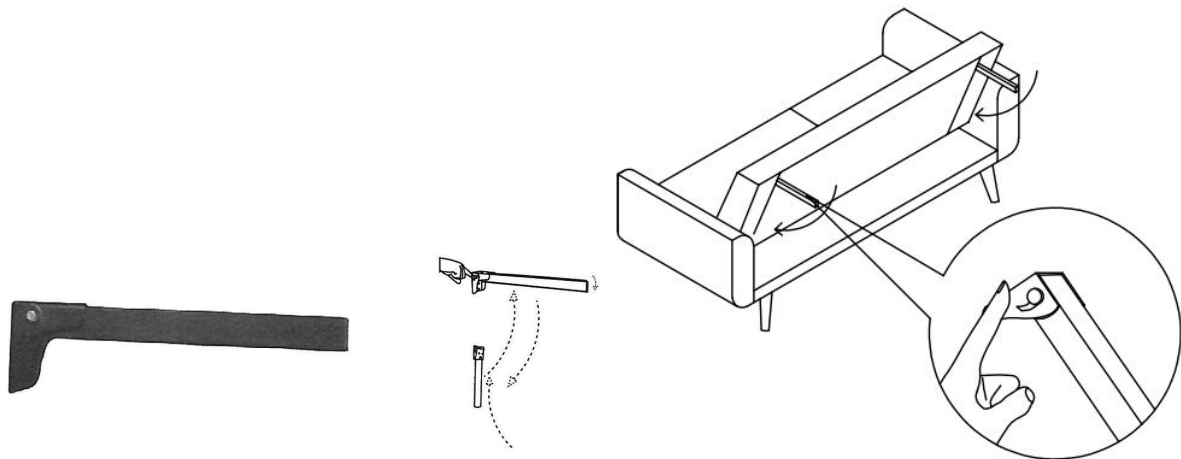

FROM SOFA TO BED: Hold the back of the sofa and tilt forward slowly until a click is heard, then lower back until the back is lying flat. Ensure that you push from the centre of the back section to avoid damaging the mechanism.

FROM BED TO SOFA: Lift the back section carefully until you hear one click for the recliner position or 2 clicks for the upright position. Ensure you lift from the centre of the back section to avoid damaging the mechanism.

Please ensure that when operating the sofa bed you always lift/push the back section from the centre to avoid damaging the mechanism.

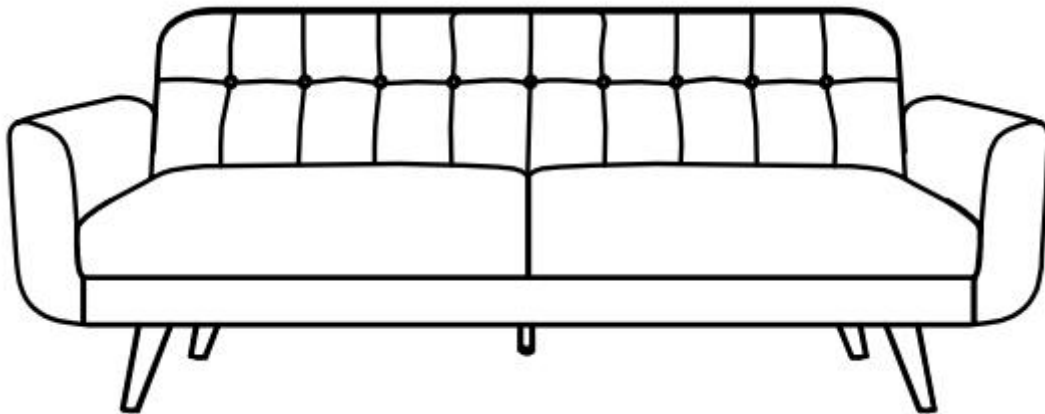

FABRIC CONTENT:

MAIN FABRIC 100% POLYESTER

OTHER FABRIC (VISIBLE):

NON-WOVEN FABRIC 100% POLYESTER