

PLEASE READ this sheet prior to assembly to familiarise yourself with the various stages of construction. Carefully open the pack supplied and check the contents against the parts and fittings check list.

Do not destroy any of the packaging until you are certain that you have all the necessary parts for the assembly.

Please ensure that the packaging is disposed of in a safe environmentally friendly way.

**CAUTION:** There are small components used in the construction of this unit. These loose items should be kept away from young children during assembly, to avoid the danger of choking.

**IMPORTANT: BEFORE STARTING TO ASSEMBLE THE BED - PLEASE READ THESE INSTRUCTIONS CAREFULLY**

### Parts Identification

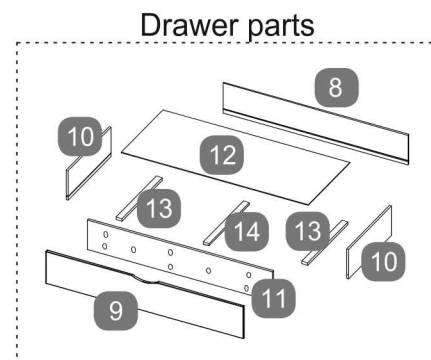
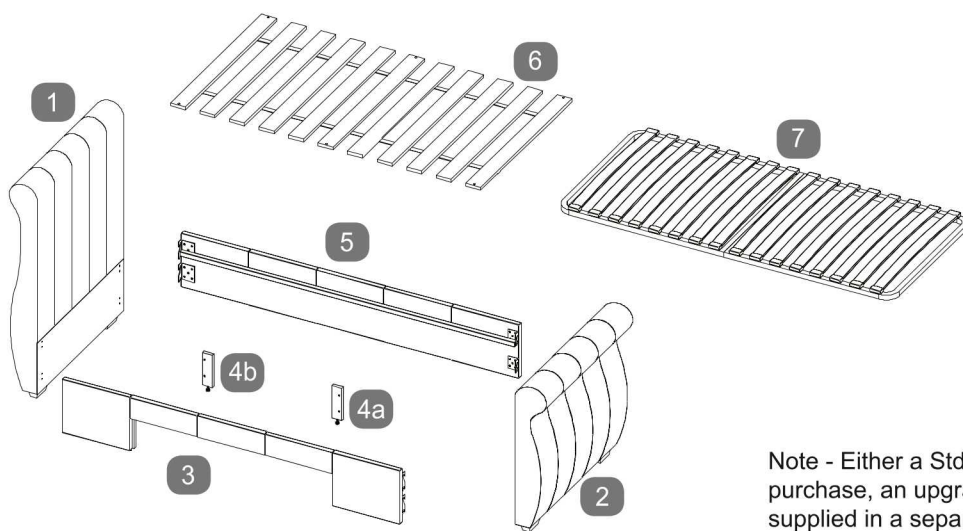

Note - Either a Std wooden Slat Set (6), or if chosen at time of purchase, an upgraded Sprung Slat Frame (7), shall be supplied in a separate box.

### Parts Checklist

Ref.	Description	Qty	Ref.	Description	Qty
1	Headboard	1	8	Drawer Back Panel	1
2	Footboard	1	9	Drawer Face Panel	1
3	Side Rail (For Drawer - fit to left or right side)	1	10	Drawer Side Panels	2
4a&4b	Adjustable Support Legs	1Pr	11	Drawer Front Panel	1
5	Side Rail (Solid)	1	12	Drawer Base Panel	1
6	Wooden Slat Set	1	13	Drawer Base Support Rails - Ends	2
			14	Drawer Base Support Rail - Centre	1
7	*Upgraded Sprung Slat Frame*	1			

\* Only supplied if upgraded sprung slat frame is chosen at time of purchase.

## Fittings Checklist

### HARDWARE NEEDED FOR BED ASSEMBLY (PACK A)

Code	Description	Qty	Code	Description	Qty
A	Bolts (M8x30mm) for fitting side panels (3&5) to headboard & footboard (1&2).	x16	D	Allen Key (for M8 bolt)	x1
B	Spring Washers (for M8 bolt)	x16	M	Bolts (M8x45mm) for fitting adjustable support legs (4) to side panel (3).	x4
C	Flat Washers (for M8 bolt)	x20			

### HARDWARE FOR FITTING WOOD SLATS OR UPGRADED SPRUNG SLAT FRAME (PACK B)

Code	Description	Qty	Code	Description	Qty
E	Bolts (M6x40mm) for fitting the wooden slat set (6) or the sprung slat frame (7) to side panels (3&5)	x6	H	Allen Key (for M6 bolt)	x1
F	Sleeve Nuts - M6	x6	V	Spring Washers (for M6 bolt)	x6
G	Flat Washers (for M6 bolt)	x6			

### HARDWARE NEEDED FOR DRAWER ASSEMBLY (PACK C)

Code	Description	Qty
J	Screws (5x50mm) for assembling drawer panels	x14
K	Screws (3.5x16mm) for fitting wheel (N) to wooden drawer support rails.	x20
L	Screws (4x30mm) for fitting drawer face panel (10)	x8
S	Plastic Barrel Nuts	x14

### WHEELS FOR DRAWER (PACK D)

Code	Description	Qty
N	Drawer Wheels	x5

## Additional Tools Required

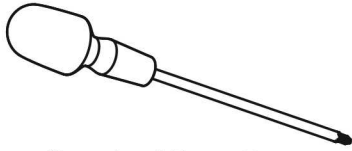

Cross-head Screwdriver

## Care & Maintenance

In the unlikely event of missing or damaged parts, please contact the customer service team on 0344 292 00 00. When calling this number, please quote the part code reference numbers shown in this leaflet when requesting spare or replacement parts.

## General Hints & Tips



Please retain your assembly instruction and tools provided for future use. Periodically check that all bolts are still tight.

This assembly requires two persons.



40 MINS

Approximate time to assemble this product

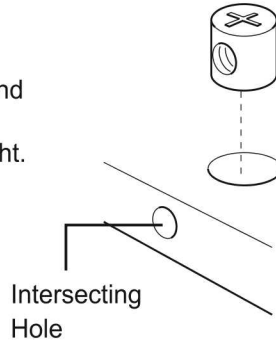

When they are supplied and are part of the assembly of this bed, ensure that the barrel nuts are fitted the correct way so the hole in the nut is facing towards the intersecting hole in the panel.

We recommend the bed is assembled in the room it shall be located in.

## Bed Assembly - Use Pack 'A'

Stage  
1

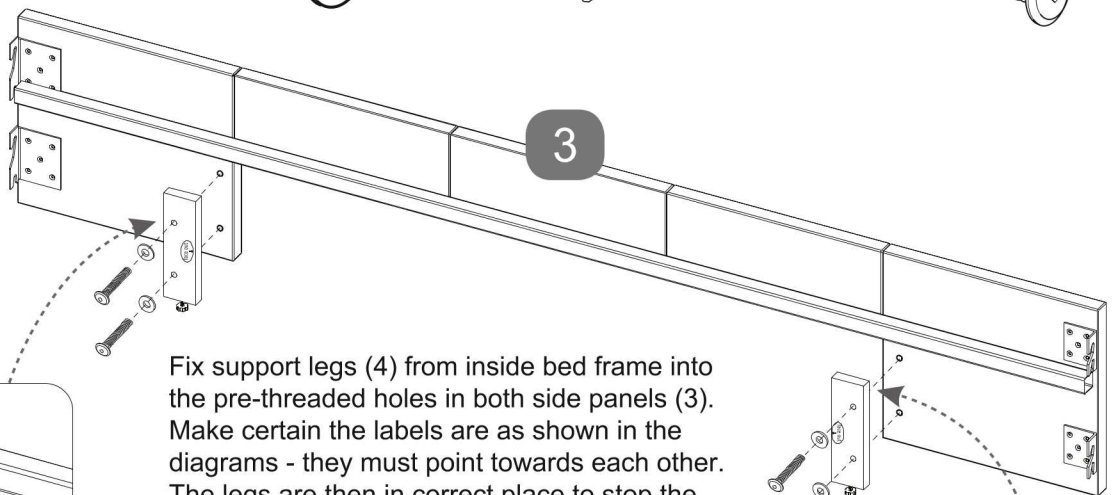

Fix support legs (4) from inside bed frame into the pre-threaded holes in both side panels (3). Make certain the labels are as shown in the diagrams - they must point towards each other. The legs are then in correct place to stop the drawer going under the bed.

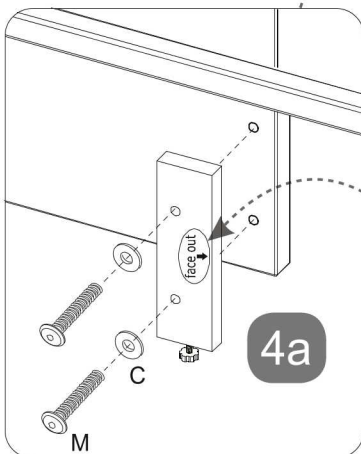

4a

face out

ARROWS ON LABELS POINT TOWARDS EACH OTHER

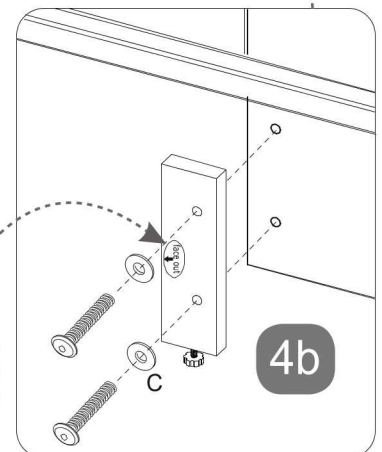

4b

face out

Adjustable Feet

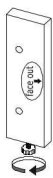





Carefully adjust feet so they just touch the floor keeping side panels level when bed is in use.

# Bed Assembly - Use Pack 'A'

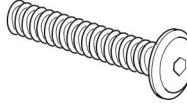
**NOTE THAT THE DRAWER CAN BE FITTED ON THE LEFT or THE RIGHT SIDE OF THE BED - CHOOSE WHICH SIDE YOU WANT THE DRAWER & FIT SIDE PANEL (3) IN THAT POSITION.**

Stage  
2

- A  x16
- B  x16
- C  x16
- D  x1

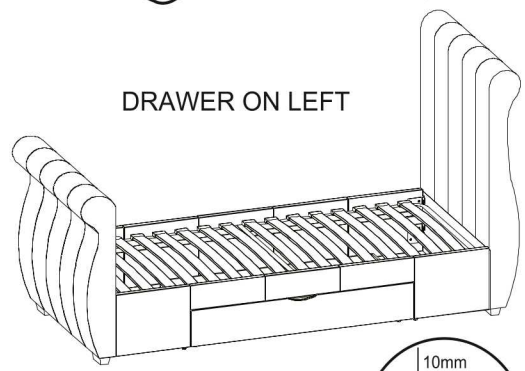
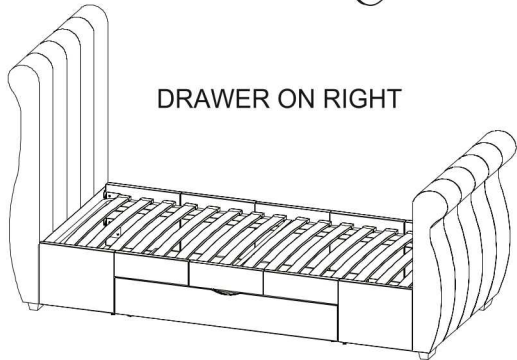

Loosely insert four bolts (A) with spring washers (B) & flat washers (C) into each side of headboard & footboard (1&2).

Note: Do not tighten fully but leave 10mm protruding as in the diagram.

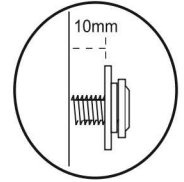

FIT BOLTS TO HEADBOARD & FOOTBOARD LIKE THIS.

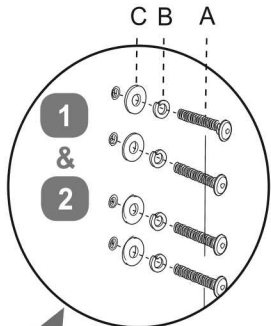

Fit the side panels locating the brackets behind the flat washers.

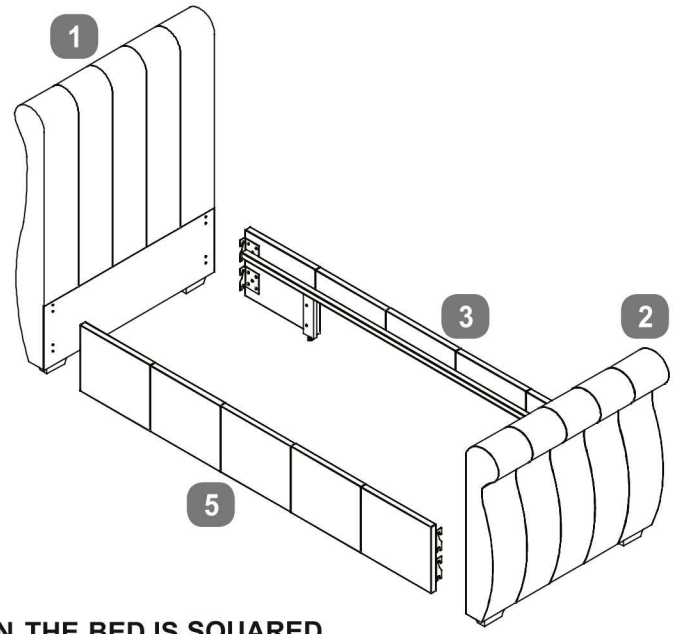
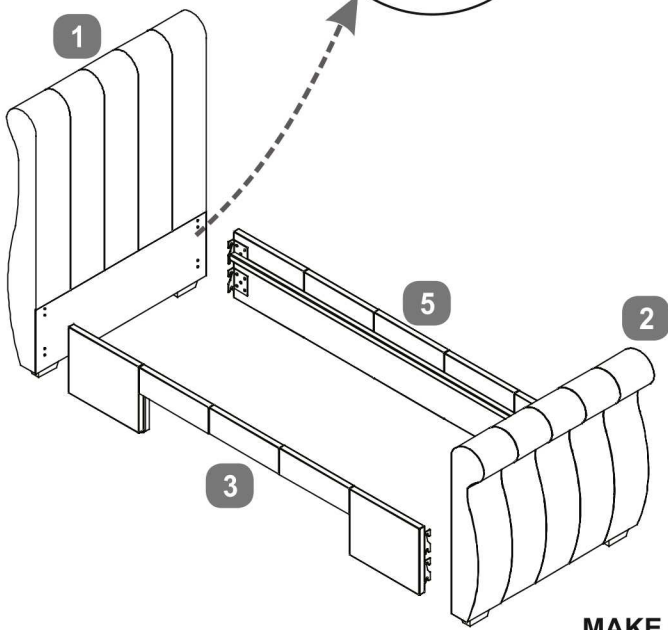
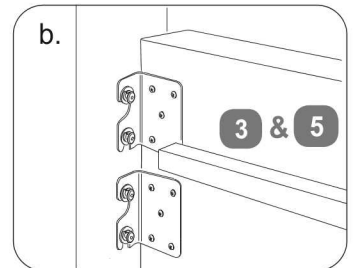
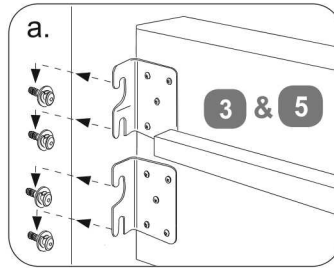

**MAKE CERTAIN THE BED IS SQUARED UP, AS SHOWN IN THE DIAGRAM.**

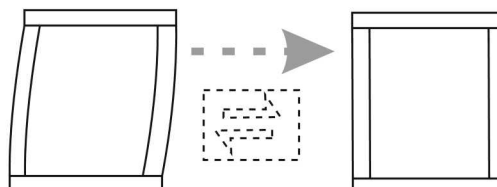

Once all four corners are located, make sure the bed is still square, then tighten all the bolts 100% using Allen key (D).

# Fitting Wooden Slat Set - Use Pack 'B'

Stage  
3a

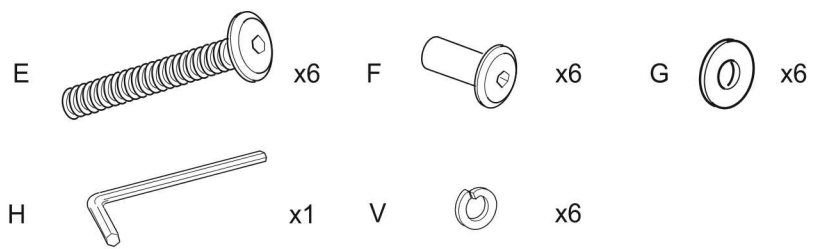

Carefully lay wooden slat set (6) on the metal supports on each side panel.

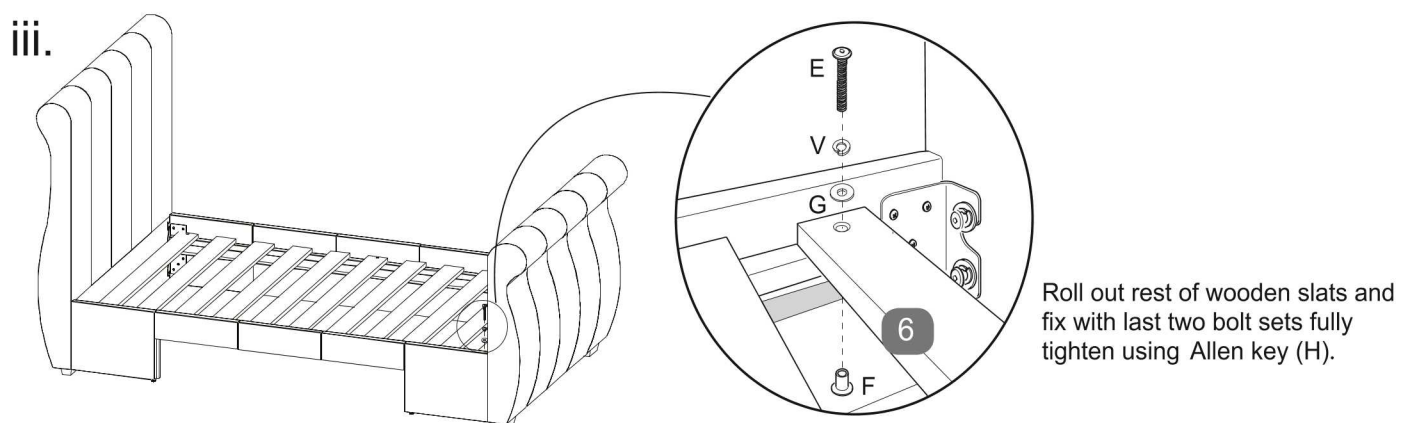
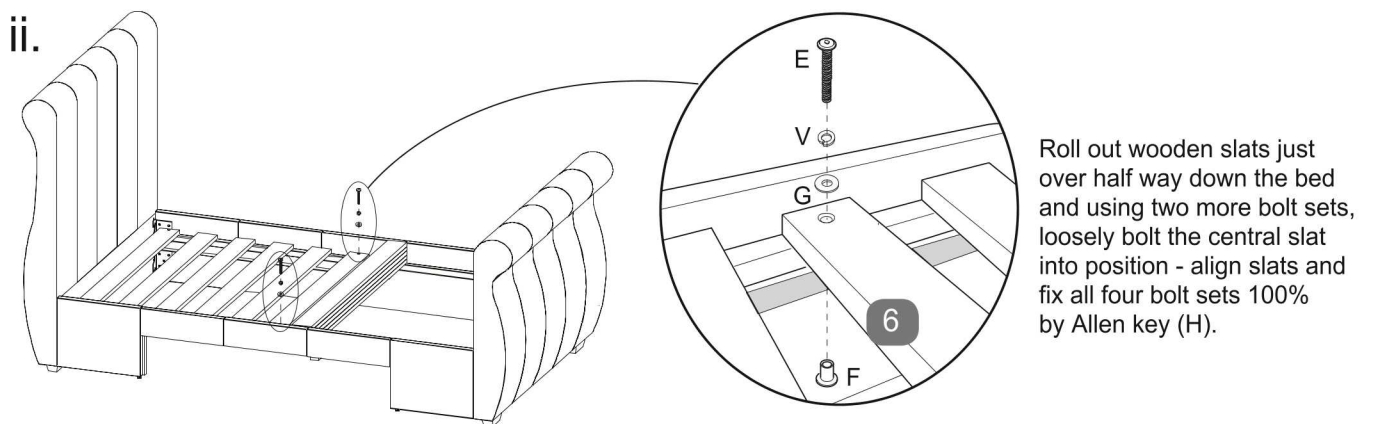
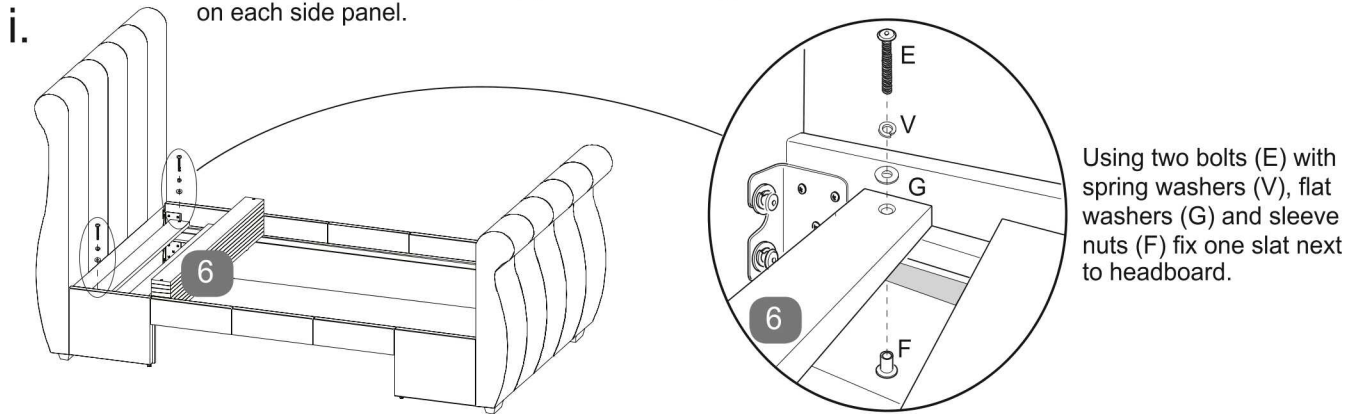

## Fitting Upgraded Sprung Slat Frame - Use Pack 'B'

Stage  
3b

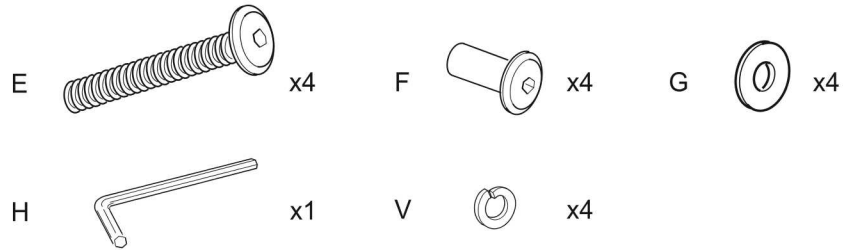

Open the sprung slat frame and lay face down on the working surface.

Carefully turn the slat frame over and position onto the metal slat supports on each side panel. Align the frame with the fixing holes at each end and secure using four sets of bolts (E), spring washers (V), flat washers (G) and sleeve-nuts (F). When all in place tighten using allen key (H).

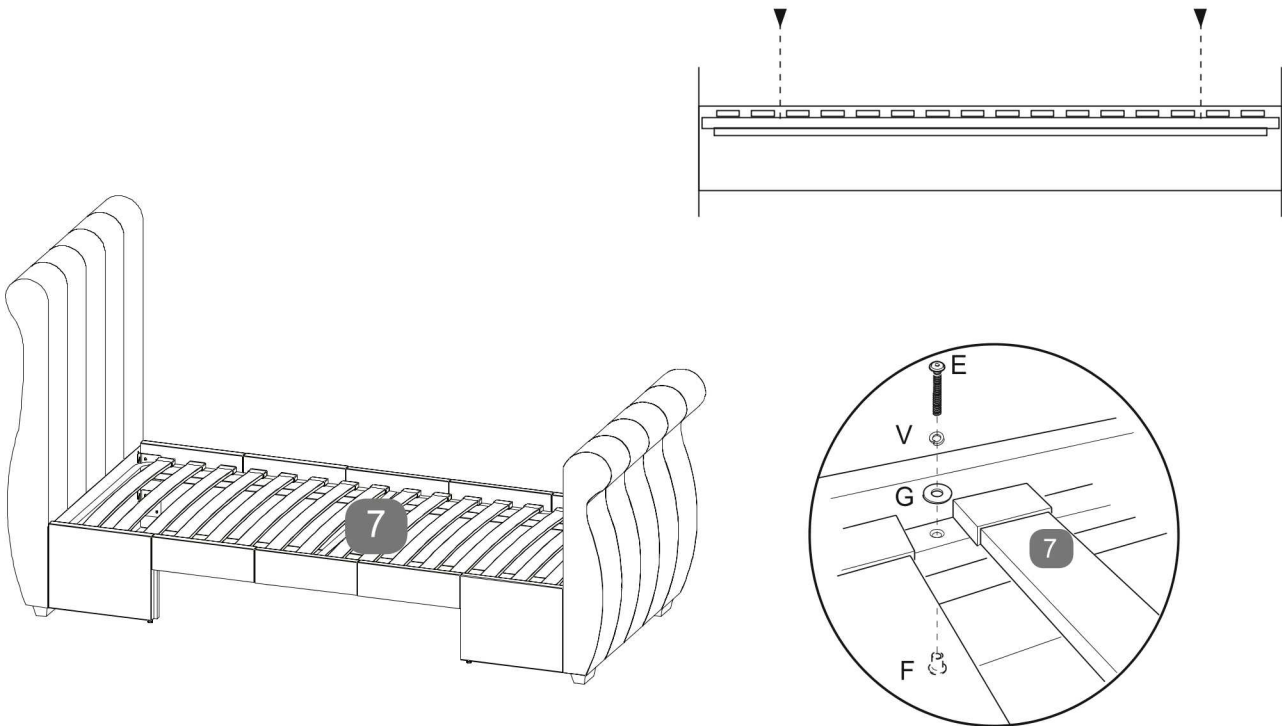

Finally, please check carefully that all bolts are fully tightened before the bed is used.

# Drawer Assembly - Use Pack 'C'

Stage  
4

i.

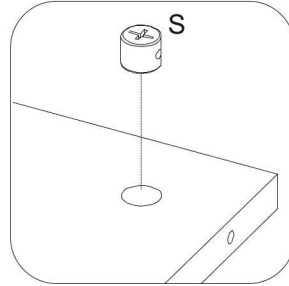
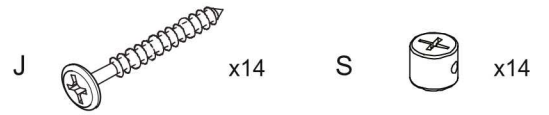
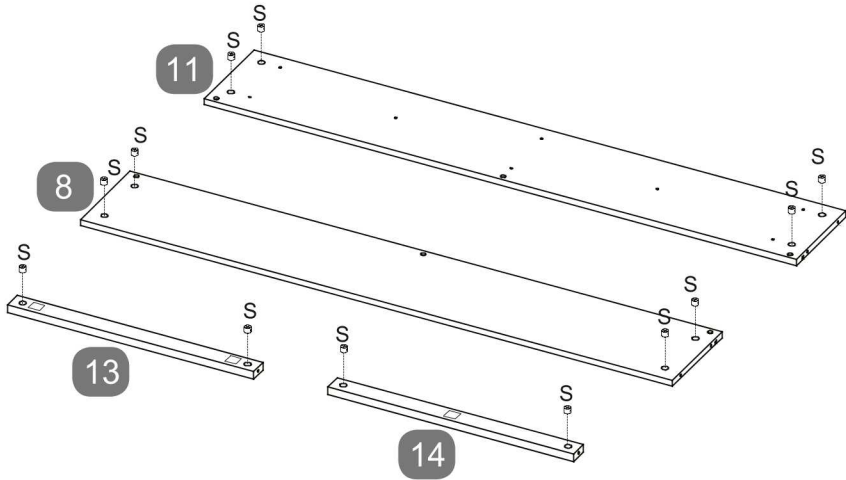

**IMPORTANT:**  
MAKE SURE WHEN FITTING THE NUTS THAT THE HOLE IS IN CORRECT ALIGNMENT WITH THE HOLE IN THE PANEL EDGE.

ii.

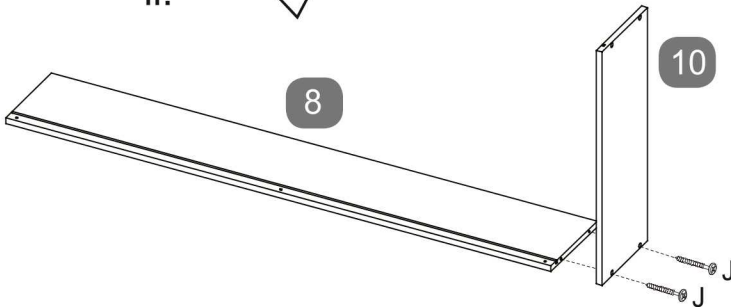

iii.

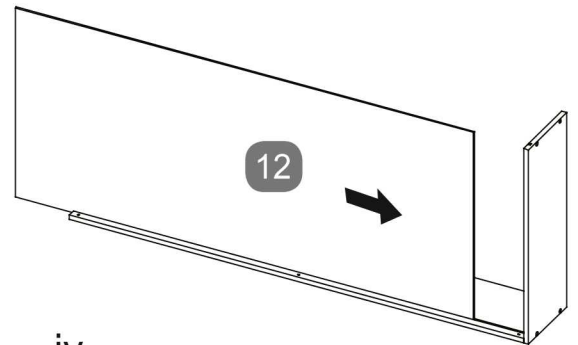

v.

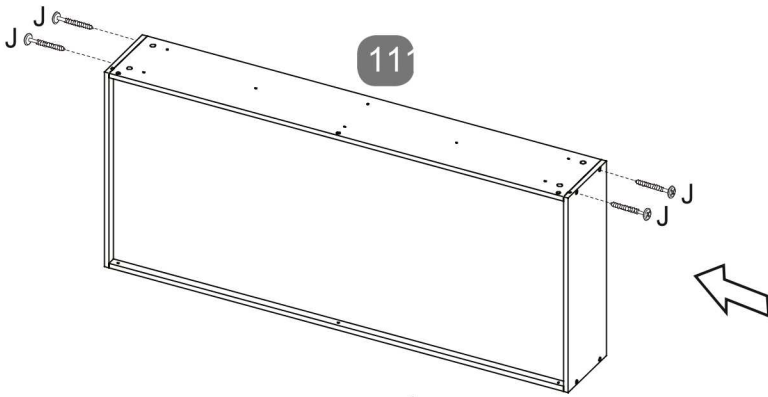

iv.

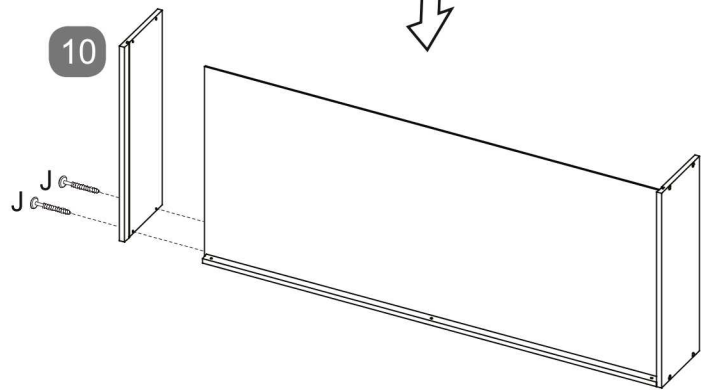

vi.

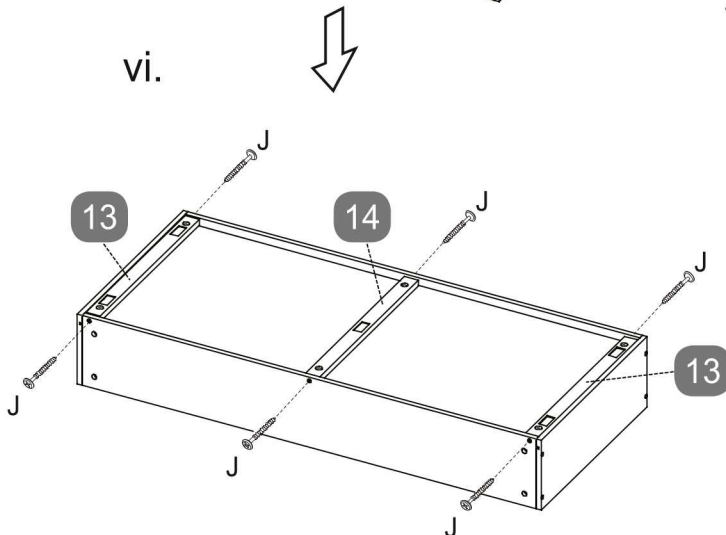

# Drawer Assembly - Use Pack 'C & D'

Stage  
5

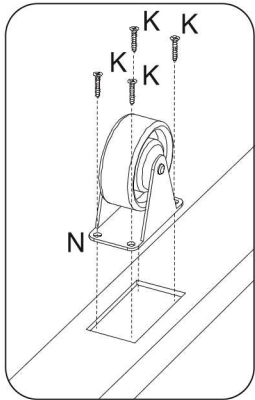
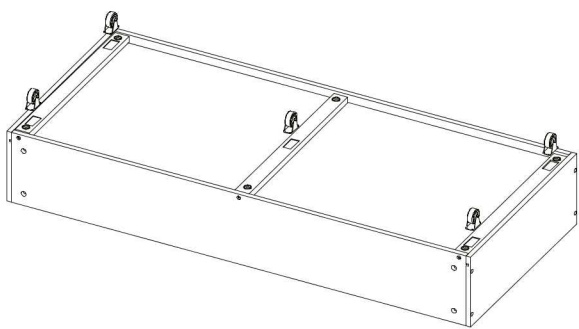

Fit the assembled drawer to rear of Drawer Face Panel (9). Carefully follow the guide lines on inside face of the rear side.

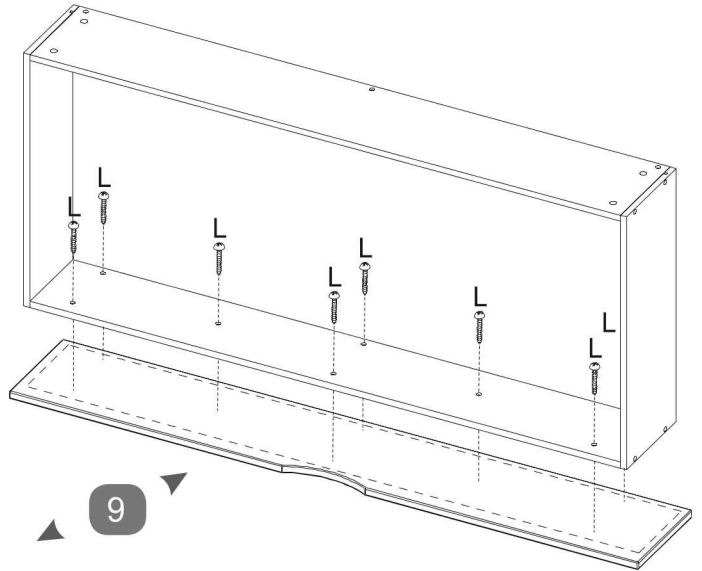

Stage  
6

SLIDE IN THE DRAWER

