

PLEASE READ this sheet prior to assembly to familiarise yourself with the various stages of construction. Carefully open the pack supplied and check the contents against the parts and fittings check list.

Do not destroy any of the packaging until you are certain that you have all the necessary parts for the assembly.

Please ensure that the packaging is disposed of in a safe environmentally friendly way.

CAUTION: There are small components used in the construction of this unit. These loose items should be kept away from young children during assembly, to avoid the danger of choking.

IMPORTANT: BEFORE STARTING TO ASSEMBLE THE BED - PLEASE READ THESE INSTRUCTIONS CAREFULLY

Parts Identification

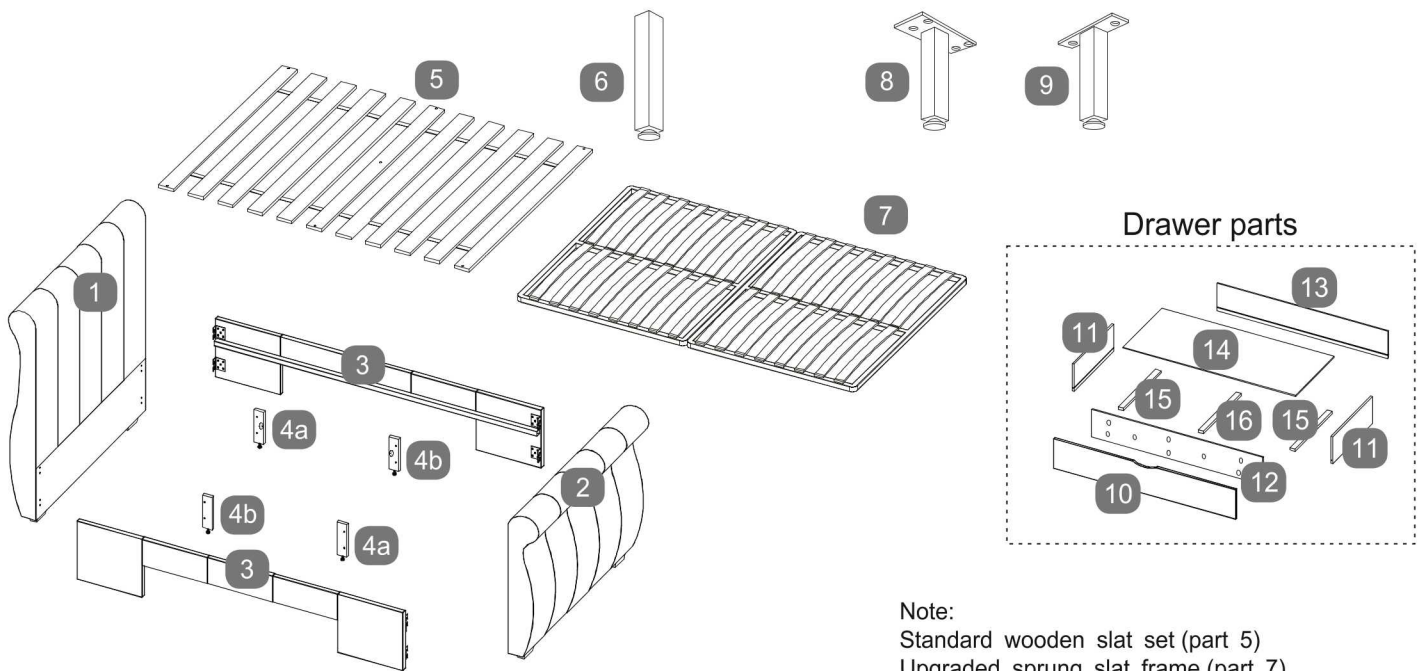

Note:
Standard wooden slat set (part 5)
Upgraded sprung slat frame (part 7)

Parts Checklist

Ref.	Description	Qty	Ref.	Description	Qty
1	Headboard	1	10	Drawer Face Panel	2
2	Footboard	1	11	Drawer Side Panel	4
3	Side Rail	2	12	Drawer Front Panel	2
4a&4b	Adjustable Support Leg	2Pr	13	Drawer Back Panel	2
5	Wooden Slat Set	1	14	Drawer Bottom Panel	2
6	Wooden Slat Set Support Leg	1	15	Drawer Bottom Support Rail - Ends	4
7	*Upgraded Sprung Slat Frame*	1	16	Drawer Bottom Support Rail - Centre	2
8	*Sprung Slat Frame Centre Support Leg*	1			
9	*Sprung Slat Frame Support Legs*	2			

* Only supplied if upgraded sprung slat frame is chosen.
Legs (8&9) are only supplied with the sprung system.

Fittings Checklist

HARDWARE NEEDED FOR BED ASSEMBLY (PACK A)

Code	Description	Qty	Code	Description	Qty
A	Bolts (M8x30mm) for fitting side panels (3) to headboard & footboard (1&2).	x16	D	Allen Key (for M8 bolt)	x1
B	Spring Washers (for M8 bolt)	x16	M	Bolts (M8x45mm) for fitting adjustable support legs (4) to side panels (3).	x8
C	Flat Washers (for M8 bolt)	x24			

HARDWARE FOR FITTING WOOD SLATS OR UPGRADED SPRUNG SLAT FRAME (PACK B)

Code	Description	Qty	Code	Description	Qty
E	Bolts (M6x40mm) for fitting the wooden slat set (5) or the sprung slat frame (7) to side panels (3)	x6	H	Allen Key (for M6 bolt)	x1
F	Sleeve Nuts - M6	x6	U	Screw for Slat Support Leg (6) - 5mm	x1
G	Flat Washers (for M6 bolt & 5mm screw)	x7	V	Spring Washers (for M6 bolt)	x6

EXTRA HARDWARE NEEDED WHEN FITTING UPGRADED SPRUNG SLAT FRAME

Note: The following fittings will be found in the box which contains the upgraded metal frame itself.

P	Bolts (M6x15mm) for fitting support legs (8&9) to the sprung slat frame (7)	x8	8	Sprung slat frame centre support leg	x1
9	Sprung slat frame support legs	x2			

HARDWARE NEEDED FOR DRAWER ASSEMBLY (PACK C)

Code	Description	Qty
J	Screws (3.5x50mm) for assembling drawer panels	x28
K	Screws (3.5x16mm) for fitting wheel (N) to wooden drawer support rails.	x40
L	Screws (4x30mm) for fitting drawer face panel (10)	x16
S	Plastic Barrel Nuts	x28

WHEELS FOR DRAWER (PACK D)

Code	Description	Qty
N	Drawer Wheels	x10

Additional Tools Required

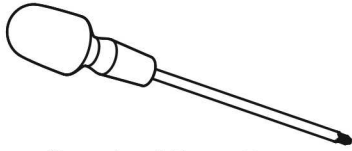

Cross-head Screwdriver

Care & Maintenance

In the unlikely event of missing parts, please contact the customer service team on 03442 92 00 00. When calling this number, please quote the part code reference numbers shown in this leaflet when requesting spare or replacement parts.

General Hints & Tips



Please retain your assembly instruction and tools provided for future use. Periodically check that all bolts are still tight.



When they are supplied and are part of the assembly of this bed, ensure that the barrel nuts are fitted the correct way so the hole in the nut is facing towards the intersecting hole in the panel.



This assembly requires two persons.



1 HOUR

Approximate time to assemble this product

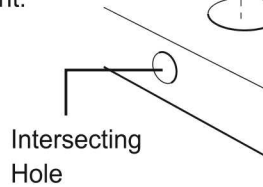

We recommend the bed is assembled in the room it shall be located in.

Bed Assembly - Use Pack 'A'

Stage
1

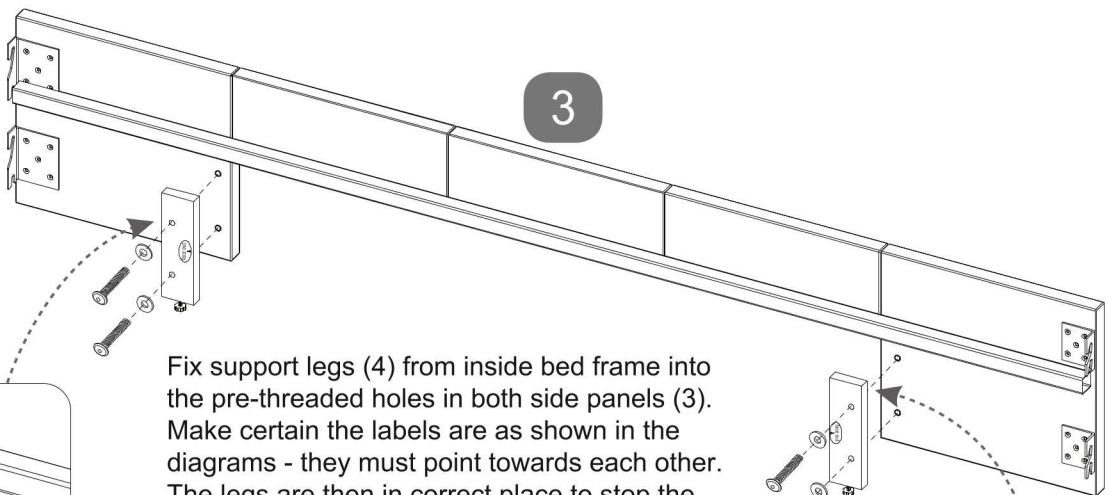
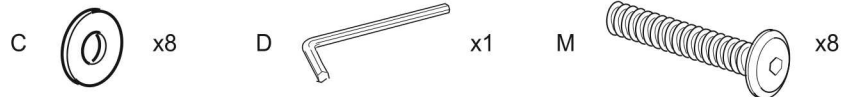

Fix support legs (4) from inside bed frame into the pre-threaded holes in both side panels (3). Make certain the labels are as shown in the diagrams - they must point towards each other. The legs are then in correct place to stop the drawer going under the bed.

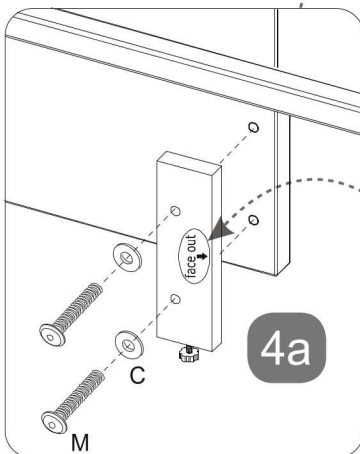

4a



ARROWS ON LABELS POINT TOWARDS EACH OTHER

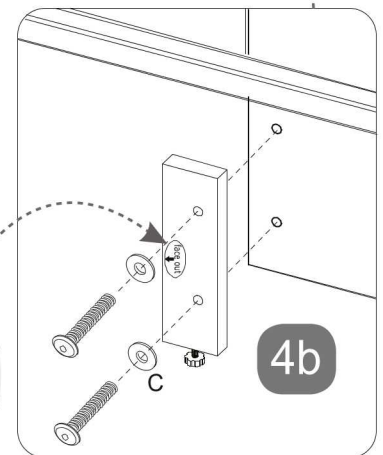

4b

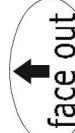

Adjustable Feet

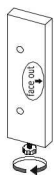

Carefully adjust feet so they just touch the floor keeping side panels level when bed is in use.

Bed Assembly - Use Pack 'A'

Stage
2

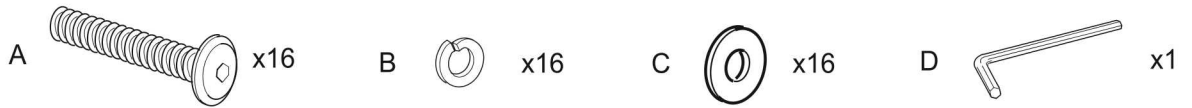

Loosely insert four bolts (A) with spring washers (B) & flat washers (C) into each side of headboard & footboard (1&2).

Note: Do not tighten fully but leave 10mm protruding as in the diagram

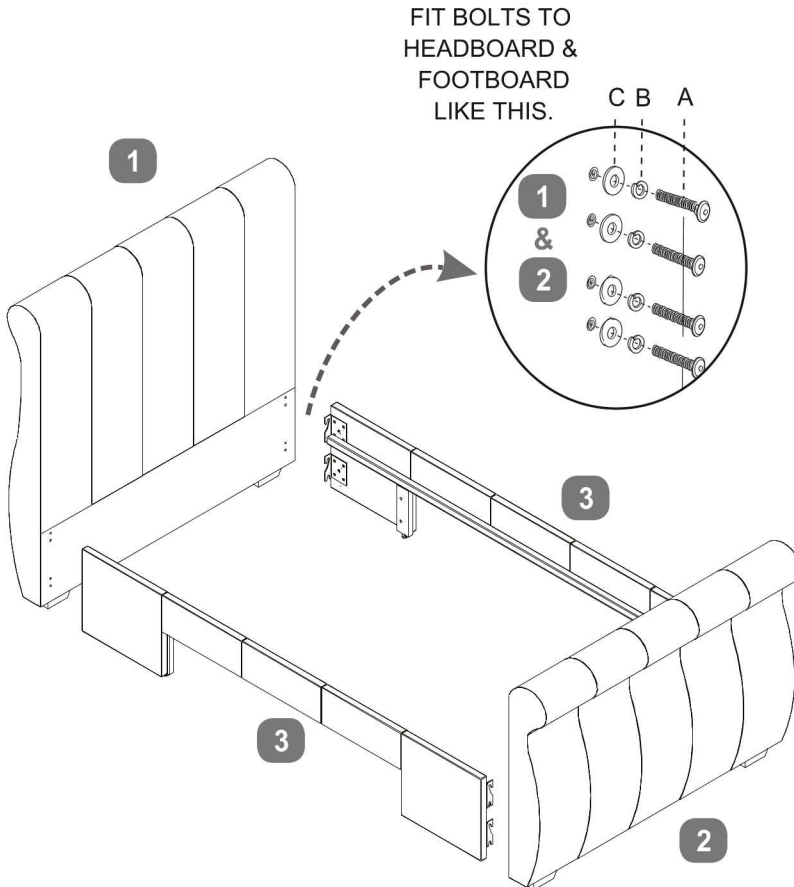
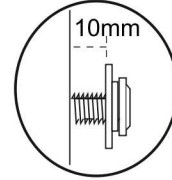

Fit the side panels locating the brackets behind the flat washers.

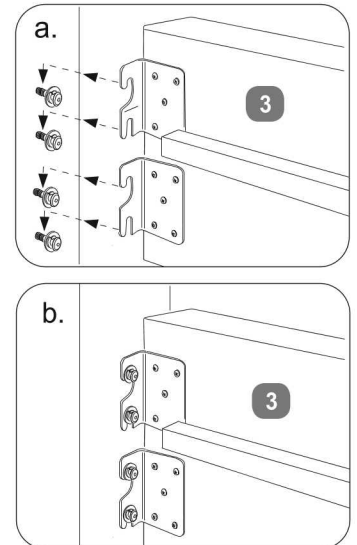

MAKE CERTAIN THE BED IS SQUARED UP, AS SHOWN IN THE DIAGRAM.

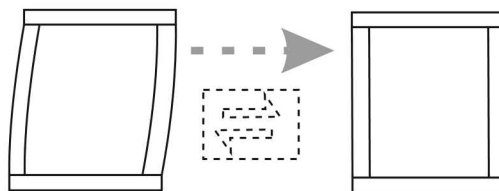

Once all four corners are located, make sure the bed is still square, then tighten all the bolts 100% using allen key (D).

Fitting Wooden Slats - Use Pack 'B'

Stage
3a

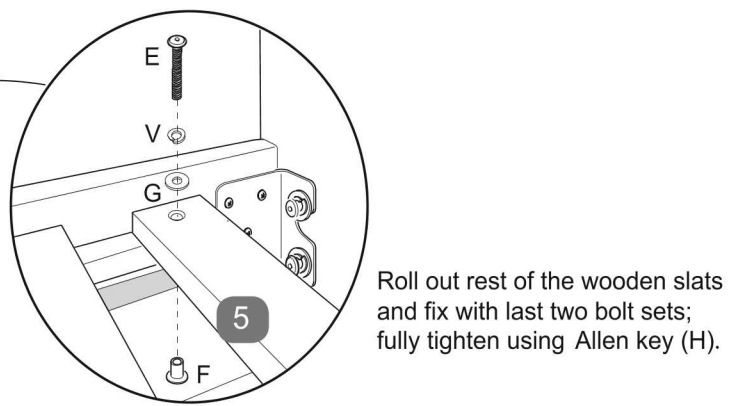
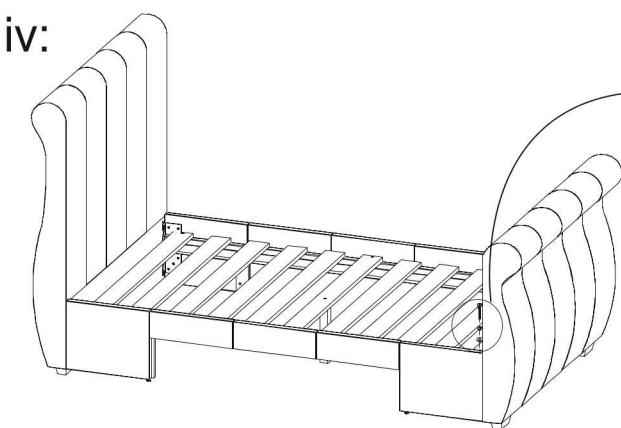
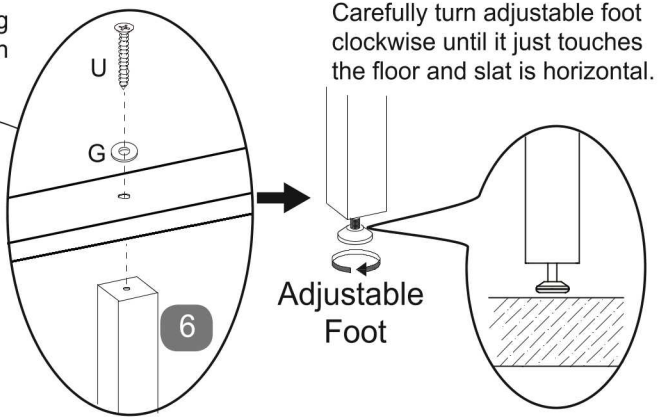
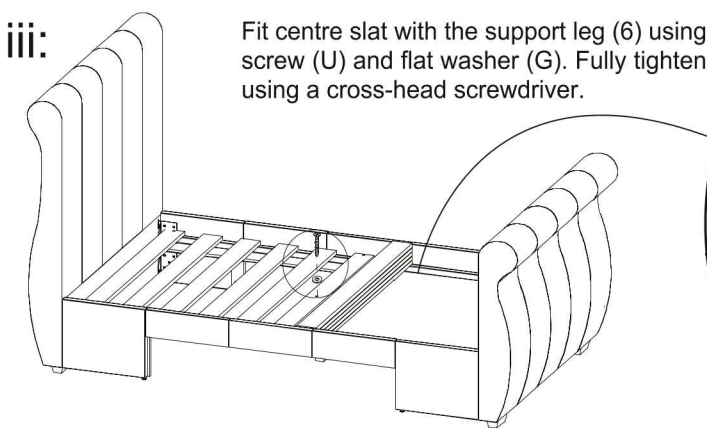
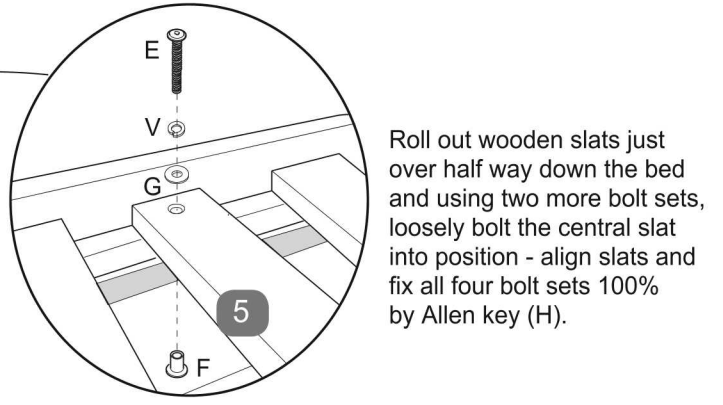
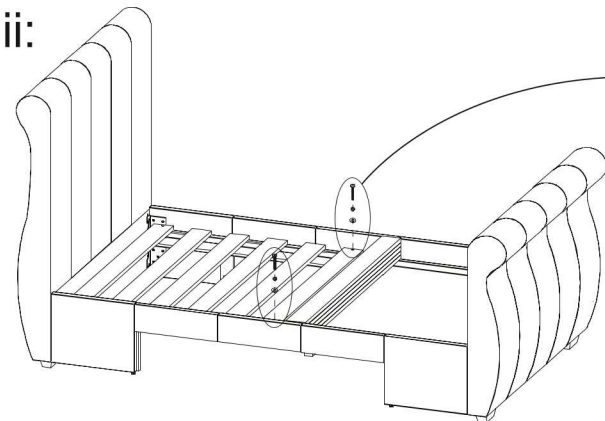
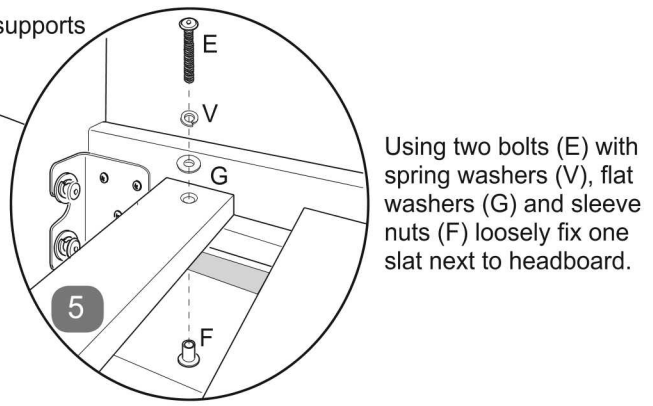
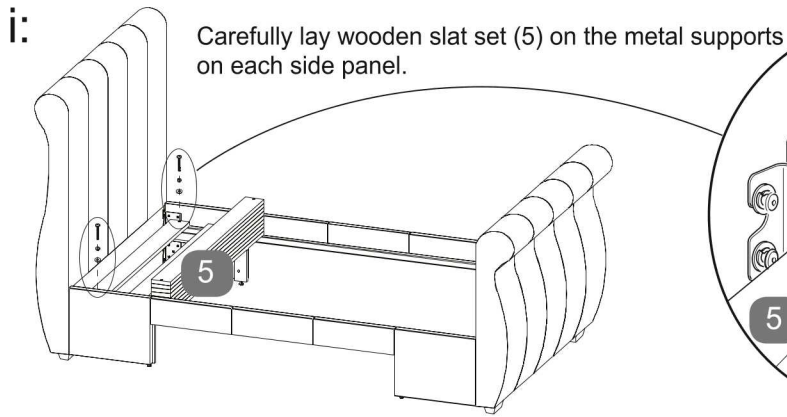
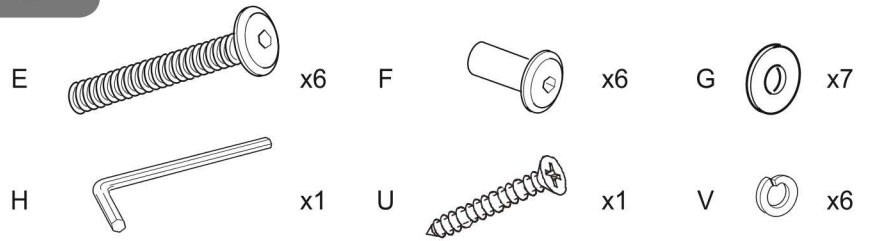

Fitting Upgraded Sprung Slat Frame - Use Pack 'B'

Stage
3b

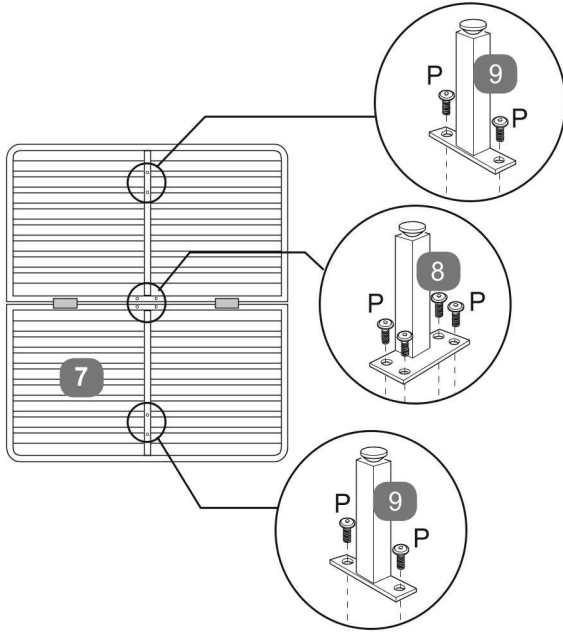
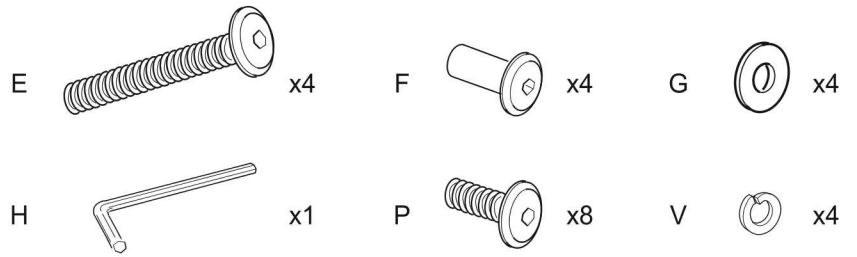

Open the sprung slat frame and lay face down on the working surface. Fit the support legs (8 & 9) to the positions shown, securing with the bolts (P). Fully tighten using Allen key (H).

Carefully turn the slat frame over and position onto the metal slat supports on each side panel. Align the frame with the fixing holes at each end and secure using four sets of bolts (E), spring washers (V), flat washers (G) and sleeve-nuts (F). When all in place tighten using Allen key (H).

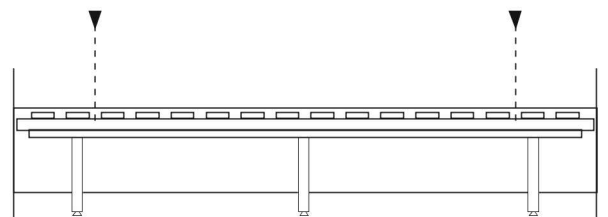
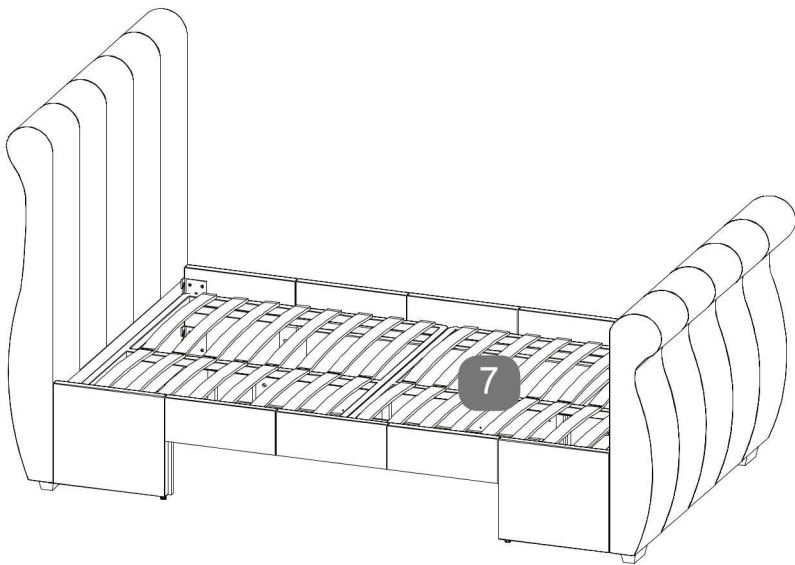
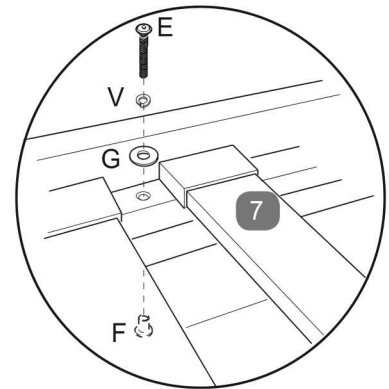

Finally, please check carefully that all bolts are fully tightened before the bed is used.

Drawer Assembly - Use Pack 'C'

Stage

4

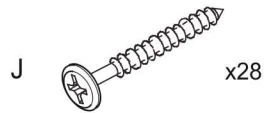

i:

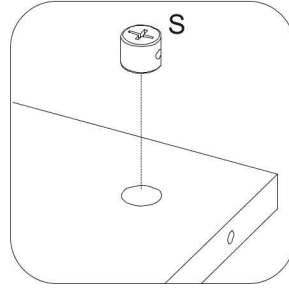
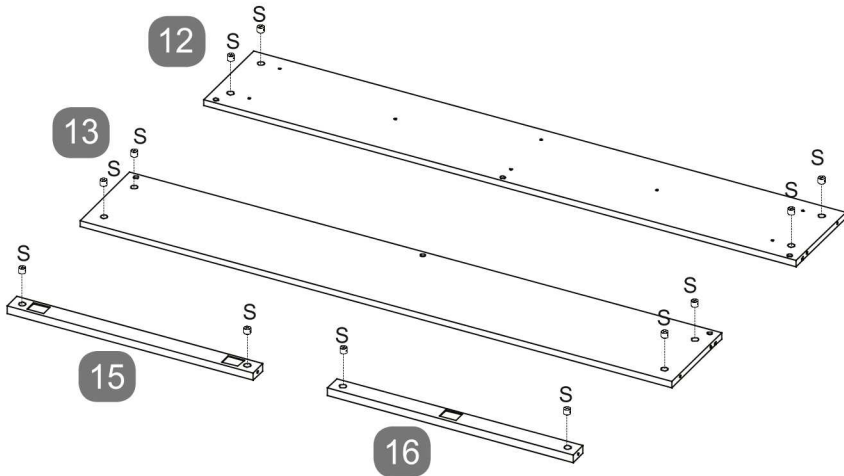

IMPORTANT:
MAKE SURE WHEN FITTING THE NUTS THAT THE HOLE IS IN CORRECT ALIGNMENT WITH THE HOLE IN THE PANEL EDGE.

ii:

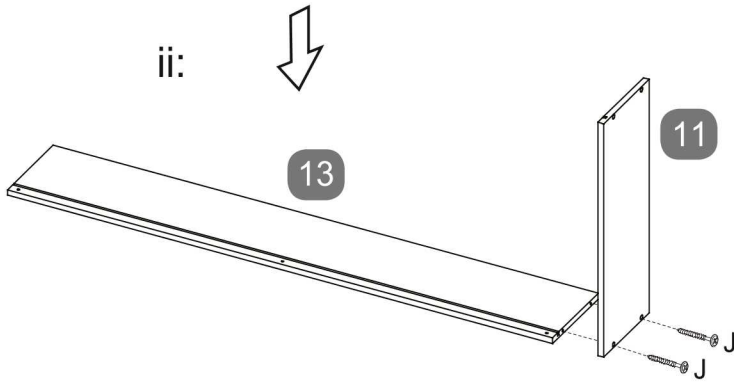

iii:

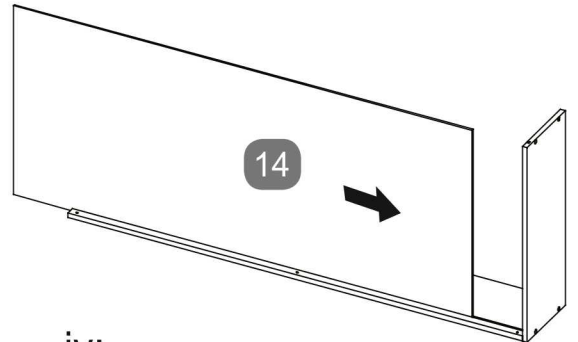

v:

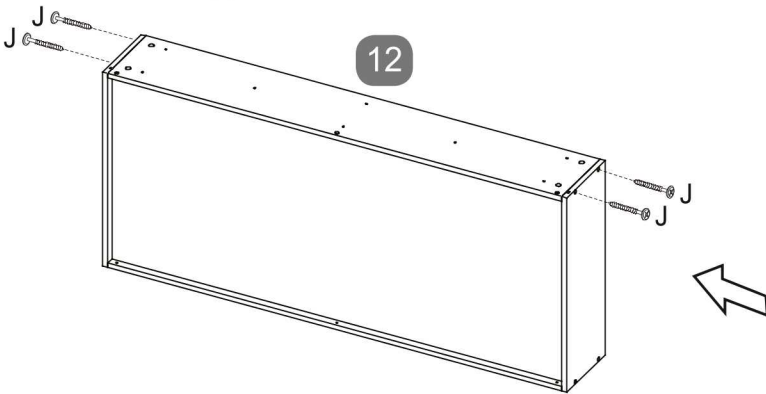

iv:

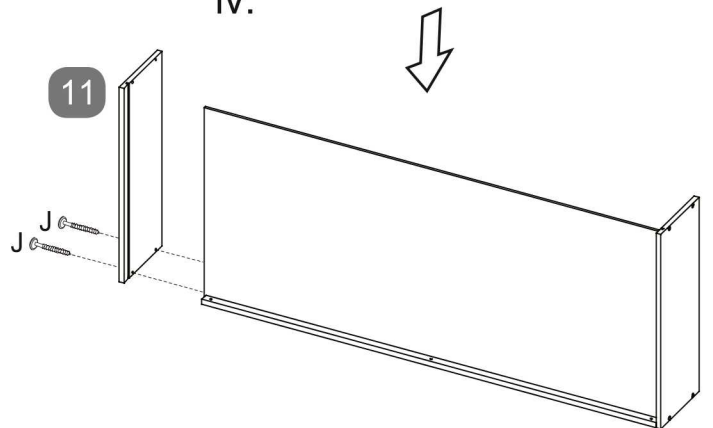

vi:

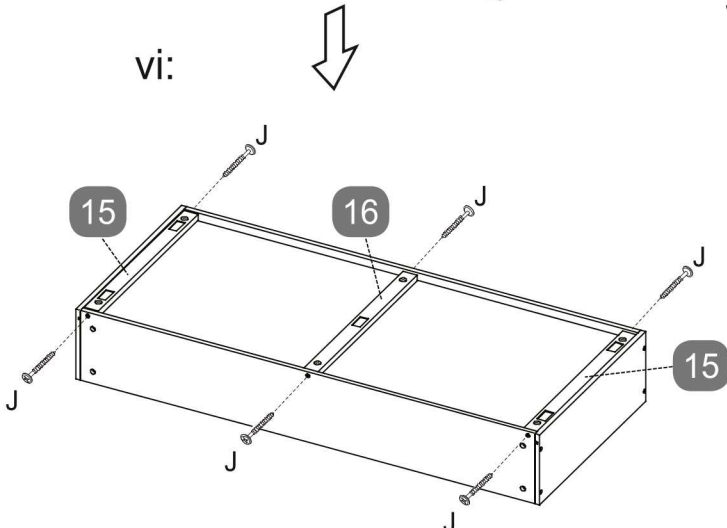

Drawer Assembly - Use Pack 'C & D'

Stage
5

- L  x16
- K  x40
- N  x10

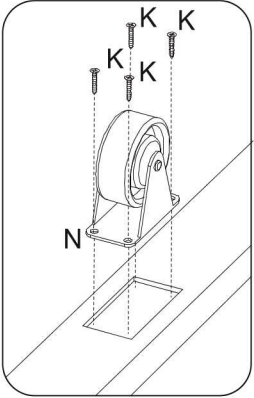
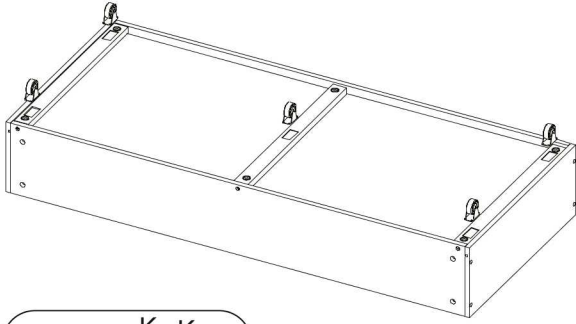

Fit the assembled drawer to rear of Drawer Face Panel (10). Carefully follow the guide lines marked on the rear of the panel.

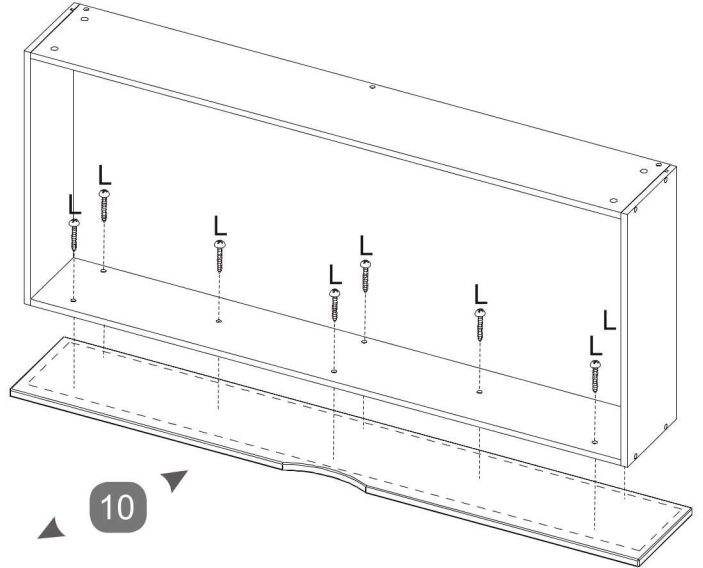

Stage
6

SLIDE IN THE DRAWERS

