



215-00945 (Solid slats)

Knox bed

215-00946 (Sprung slats)

Assembly Instructions

Minimum No. of people recommended to assemble this product:

2

Approx assembly time:

1/2
hours

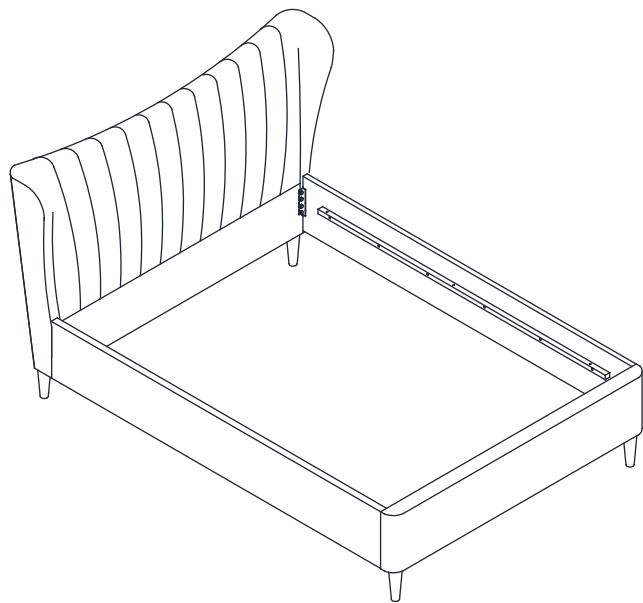

Before you Start, here are some helpful advices.

1. We suggest you spend a short time reading through this leaflet and then follow the simple step by step instructions.
2. If you follow the instructions carefully the end result should be worth the effort.
3. Do not discard any of the packaging until you have checked that you have all the parts and the pack of fittings.
4. Assemble this product on a carpet.
5. To ensure an easier assembly, we strongly advise that all fittings are only finger tightened during initial assembly. Only upon completion of the. Assembly should all fixing points be fully tightened.
6. We recommend a periodic check on all fixing points to make sure they remain fully tightened.
7. Keep glue and fittings out of children's reach.

In the unlikely event that this product has missing or damaged parts, please call 03442 920000 to obtain spares

PARTS

Fittings

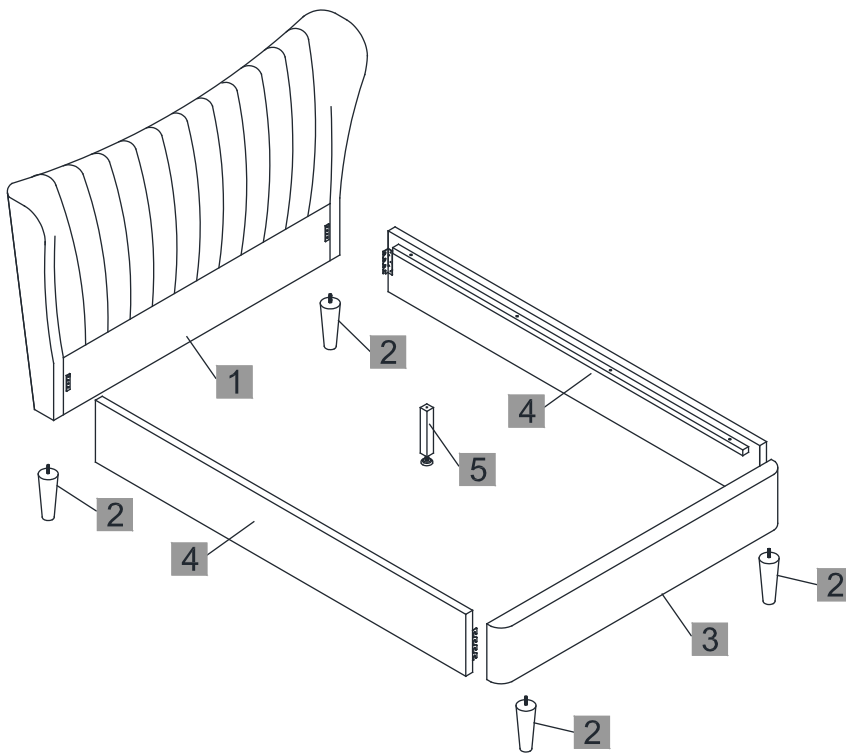

NO. PART LIST

QTY

(1)	HEADBOARD	1
(2)	FOOTBOARD	1
(3)	WOODEN FEET	4
(4)	SIDE RAILS	2
(5)	SUPPORT LEG	1

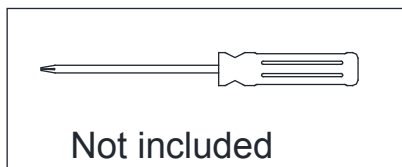

A

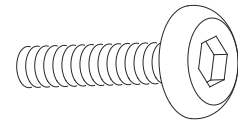

M6x35mmx6 pcs

B

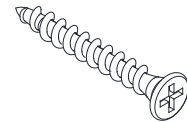

M3x35mmx1pc

C

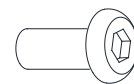

M6nut x6pcs

D



M6 Washer x6 pcs

E



M4Allen key x 2pcs

F



M5Allen key x 1pc

G

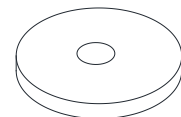

Plastic Washer x 4pcs

ASSEMBLY

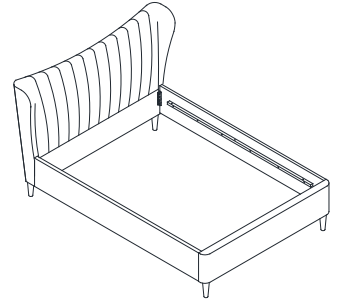

(1). Attach the Wooden Feet to the headboard and footboard by using Plastic Washer (G) .

(2). Loosen the pre-assembled bolts on the headboard and footboard with the Allen Key(F)

Note: Leave 10 mm protruding as in the diagram

STEP 1

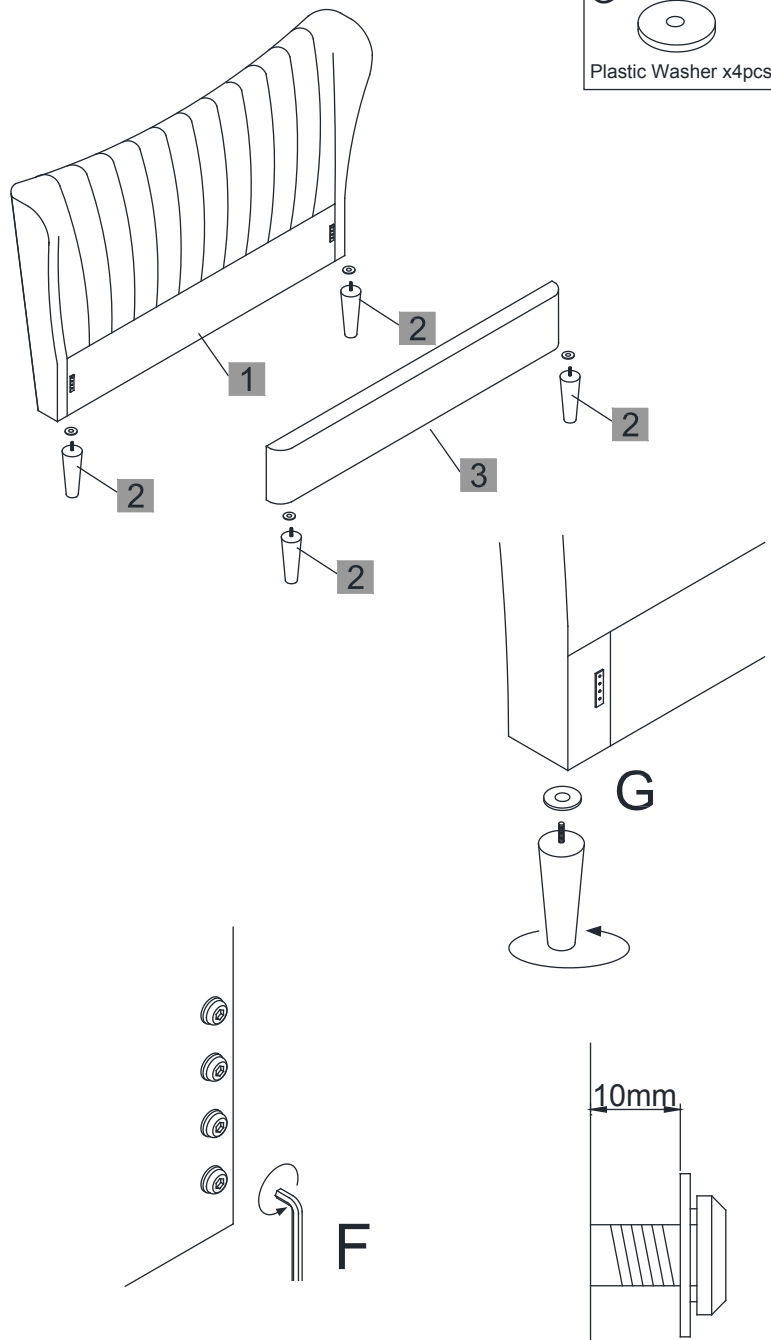

ASSEMBLY

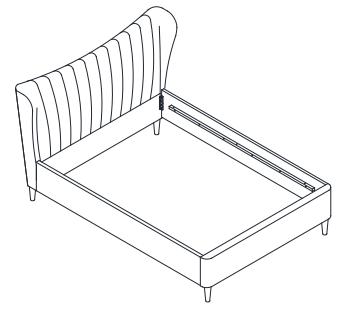

(1). Attach the side rails to the headboard and footboard.

STEP 2

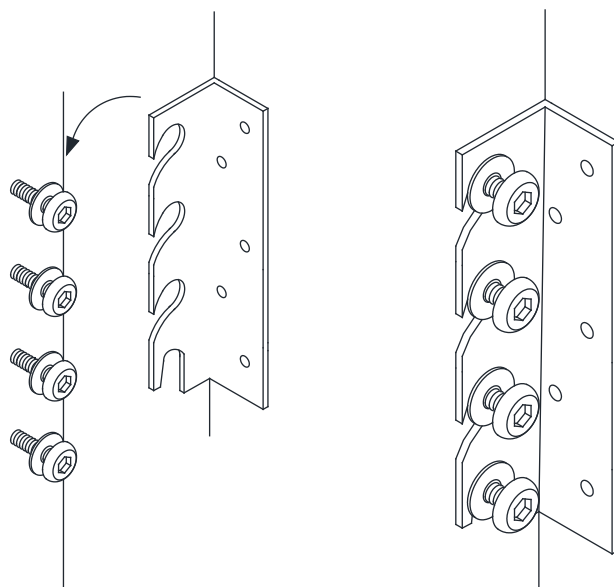
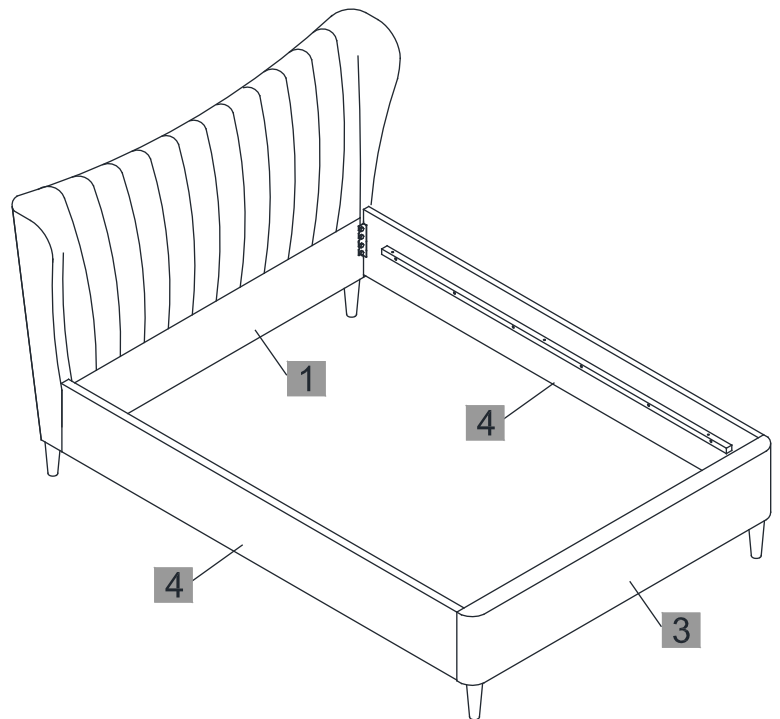

ASSEMBLY

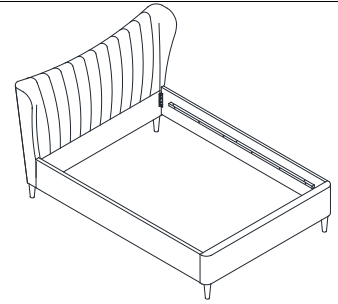

MAKE CERTAIN THE BED IS SQUARED UP .AS SHOWN ON THE RIGHT.

Once all four comers are located. make sure the bed is still square as in the sketch.then tighten all the bolts 100% using Allen key (F).

STEP 3

F



M5 Allen key × 1pcs

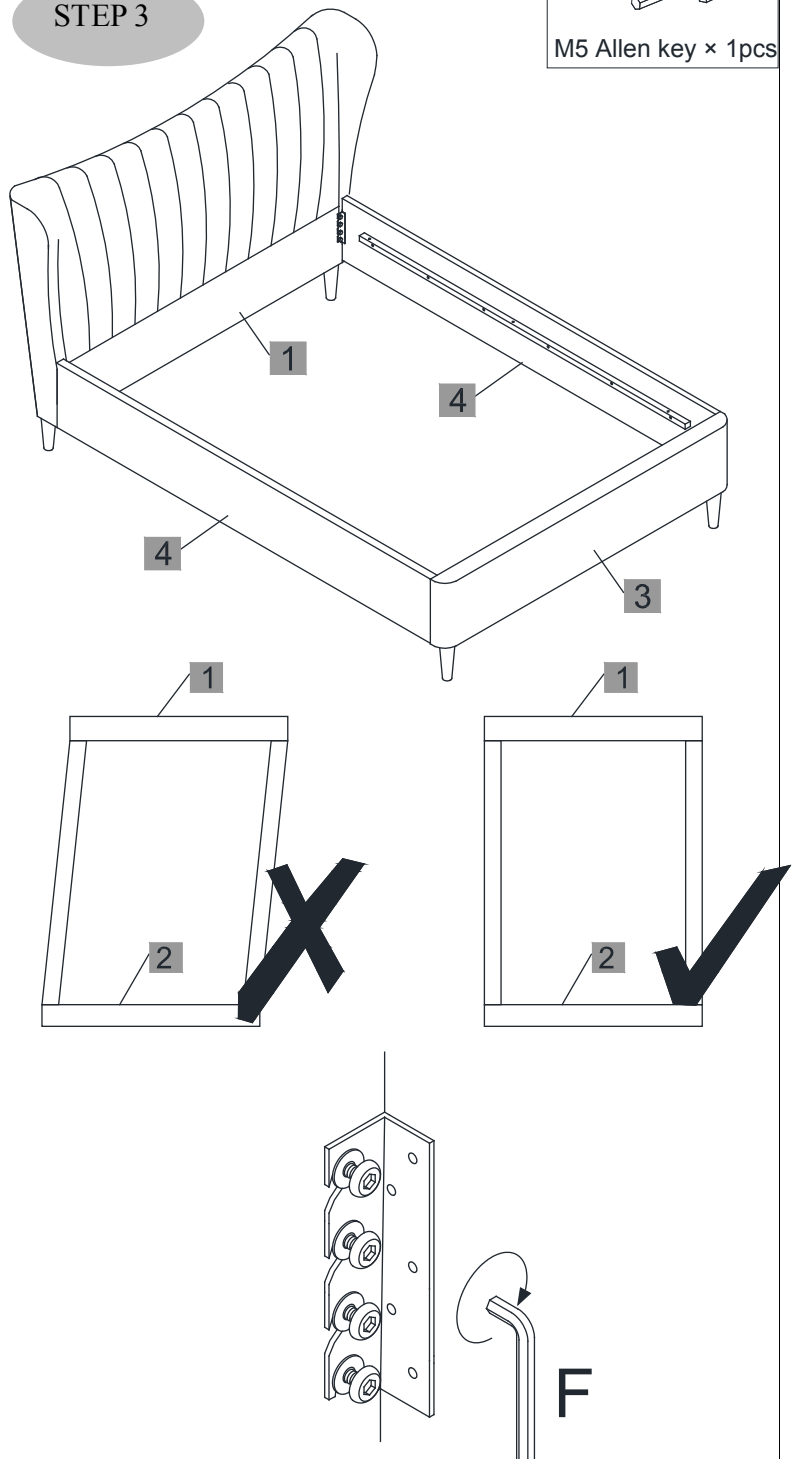

ASSEMBLY



^S **NOTE:** Slats not supplied shown for reference only.





Both slats on "step 3" and "step 4" can be assembled to the bedstead. You can make a choice between the two slats.

OPTION "A": DREAMS FIXED WOOD SLATS

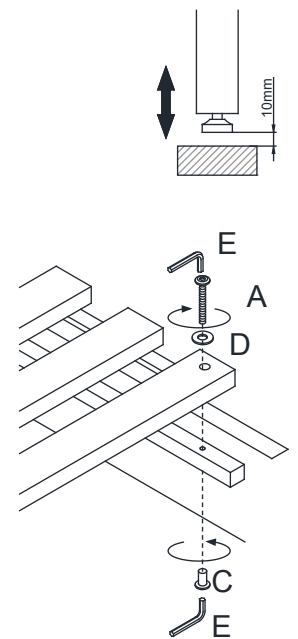
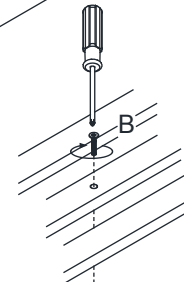
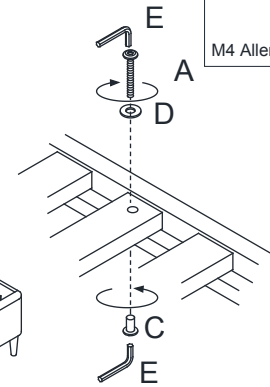
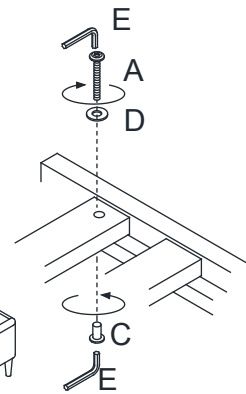
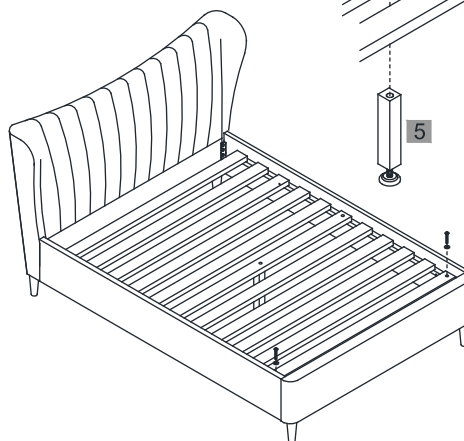
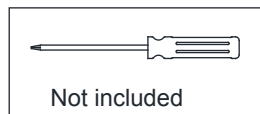
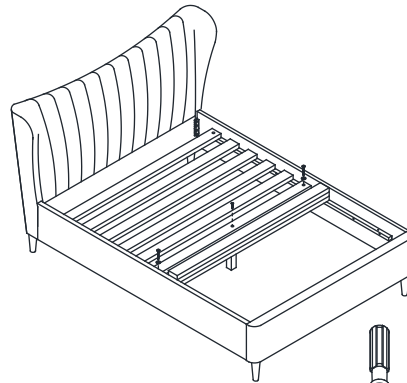
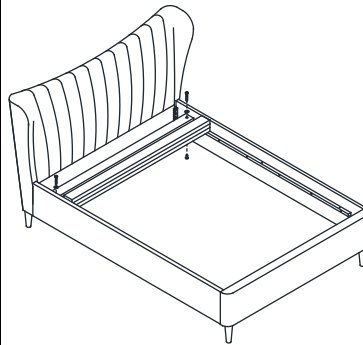
- (1) Carefully locate the slats onto the unit. Fix one end of slats.
- (2) Use bolt (A), Washer (D) and JCN nut (C) to fix the unit using Allen Key (E).
- (3) Use Tapping Screw (B) to fix the Support leg
- (4) Fix all other slats.
- (5) By hand insert adjustable feet into each support leg by turning clockwise.

STEP 4



- A**  M6 x 35 mm x 6 pcs
- B**  M3 x 35 mm x 1 pc
- C**  M6 nut x 6 pcs
- D**  M6 Washer x6pcs
- E**  M4 Allen key x 2 pcs

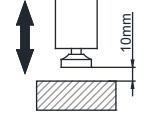

ASSEMBLY

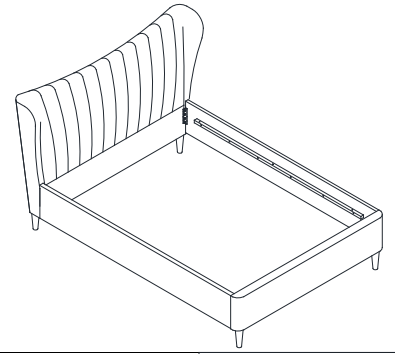

OPTION "B": DREAMS SPRUNG SLATS

1) Use the bolt to fix support leg onto the slat frame. Please note that these bolts are to be found inside the slat frame box.

2) Carefully locate the slats onto the unit.

3) Use bolt (A), Washer (D) and JCN nut (C) to fix the unit using Allen Key (E)

STEP 5

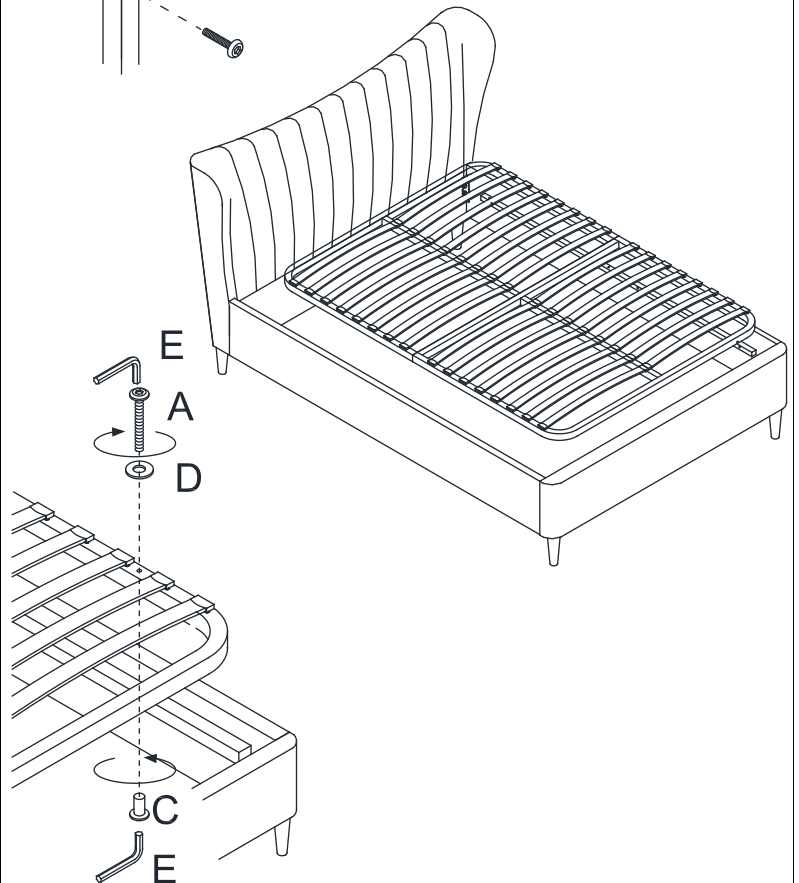
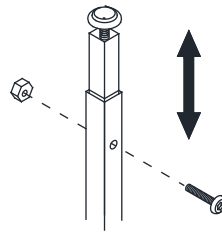
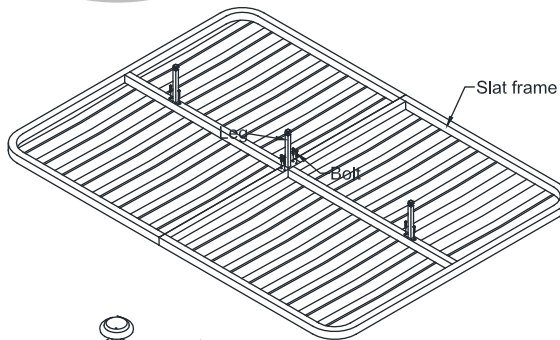

A



M6 × 35 mm × 6 pcs

C



M6 nut × 6 pcs

D



M6 Washer x6pcs

E



M4 Allen key × 2 pcs