

2099COMB

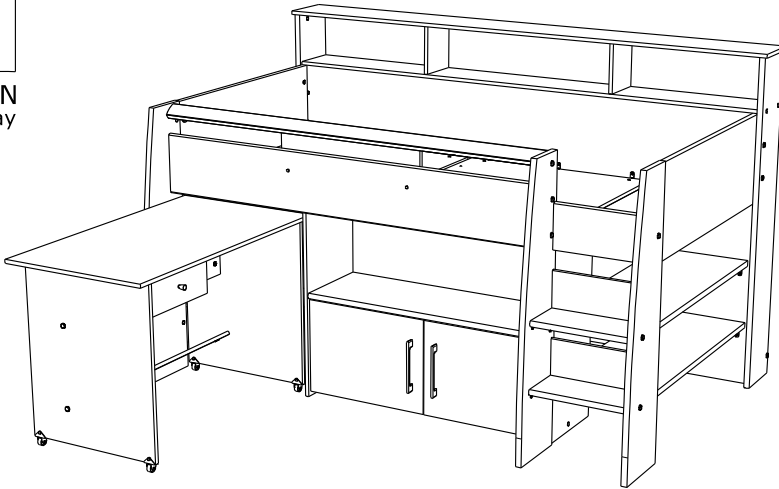

PARISOT S.A.S. , 70800 ST LOUP SUR SEMOUSE -FRANCE-



- FR** LE COUCHAGE EN HAUTEUR NE CONVIENT PAS AUX ENFANTS DE MOINS DE 6 ANS
EN THE TOP BUNK IS NOT RECOMMENDED FOR CHILDREN UNDER 6
DE HOCHBETTEN SIND NICHT FÜR KINDER UNTER 6 JAHREN GEEIGNET
ES NO SE RECOMIENDA ACOSTAR A NIÑOS MENORES DE 6 AÑOS EN ALTO
PT AS CAMAS EM ALTURA NÃO SÃO APROPRIADAS PARA CRIANÇAS COM MENOS DE 6 ANOS
IT IL PIANO SUPERIORE DEI LETTI A CASTELLO NON È ADATTO AI BAMBINI DI ETÀ INFERIORE AI 6 ANNI
NL HOOGSLAPERS ZIJN NIET GESCHIKT VOOR KINDEREN ONDER DE 6 JAAR
CZ LEŽENÍ VE VÝŠCE NENÍ VHODNÉ PRO DĚTI DO 6 LET
HU A FELSŐ FEKVŐHELY NEM ALKALMAS 6 ÉVEN ALULI GYERMEK SZÁMÁRA.
PL SPANIE NA GÓRZE NIE JEST DOZWOLONE DLA DZIECI PONIŻEJ 6 ROKU ŻYCIA
RO PATUL ÎNALT NU ESTE RECOMANDAT PENTRU COPIII MAI MICI DE 6 ANI
RU СОН НА ВЕРХНЕМ ЯРУСЕ НЕ РАЗРЕШАЕТСЯ ДЕТЯМ ДО 6 ЛЕТ
SK V HORNEJ ČASTI NESMÚ SPAŤ DETI MLADŠIE AKO 6 ROKOV
TR 6 YAŞINDAN KÜÇÜK ÇOCUKLARIN ÜST TARAFTA YATMASI UYGUN DEĞİLDİR
 النوم في السرير العلوي لا يناسب الأطفال الذين تقل أعمارهم عن 6 أعوام.



FR Remerciements :

Nous vous remercions d'avoir choisi un meuble créé et fabriqué par le Groupe Pariset et espérons qu'il vous donnera entière satisfaction.

EN Thanks:

Thank you for choosing furniture designed and manufactured by the Pariset Group. We hope you are totally satisfied with your purchase.

DE Danksagung:

Wir danken Ihnen für den Kauf eines Frankreich von der Pariset-Gruppe entworfenen und hergestellten Möbelstücks und hoffen, dass Sie es zu Ihrer vollkommenen Zufriedenheit finden werden.

ES Agradecimientos:

Les damos las gracias por haber elegido un mueble diseñado y fabricado por el Groupe Pariset y esperamos que sea de su total agrado.

PT Agradecimentos:

Obrigado por ter escolhido um móvel concebido e fabricado pelo Grupo Pariset, esperando que seja do seu inteiro agrado.

IT Ringraziamenti:

Grazie per avere scelto un mobile progettato e fabbricato dal Gruppo Pariset. Speriamo soddisfatti appieno le vostre esigenze.

NL Bedankje:

Wij bedanken u voor de aankoop van een door de Groep Pariset ontworpen en vervaardigd meubel en hopen dat u er veel plezier aan zult beleven.

CZ Poděkování:

Děkujeme, že jste si vybrali nábytek navržený a vyrobený společností Pariset Group. Doufáme, že budete svým nákupem naprosto spokojeni.

HU Köszönet:

Köszönjük, hogy a Pariset Groupe által létrehozott és gyártott bútort választott, reméljük, hogy elégedett lesz a termékkel.

PL Podziękowania:

Dziękujemy za wybór mebli stworzonych i wyprodukowanych przez Grupę Pariset. Mamy nadzieję, że będziecie Państwo w pełni zadowoleni z zakupu.

RO Mulțumiri:

Vă mulțumim că ați ales un articol de mobilier conceput și fabricat de Grupul Pariset și sperăm că veți fi pe deplin satisfăcuți de acesta.

RU Благодарность:

Мы благодарим вас за то, что вы выбрали мебель, созданную и произведенную Групп Паризо, и надеемся, что вы будете полностью удовлетворены нашей продукцией.

SK Pod'akovanie:

Ďakujeme, že ste si vybrali nábytok navrhnutý a vyrobený spoločnosťou Pariset Group. Dúfame, že budete svojim nákupom absolútne spokojní.

TR Teşekkür ederiz:

Pariset Group tarafından tasarlanan ve üretilen bu mobilyayı seçtiğiniz için teşekkür ederiz. Ürünümüzden memnun kalmanızı ümit ederiz.

AR : شكر

نشكركم لاختياركم هذه القطعة من الأثاث من تصميم وتصنيع مجموعة باريزو Pariset ونتمنى أن تنال رضائكم.

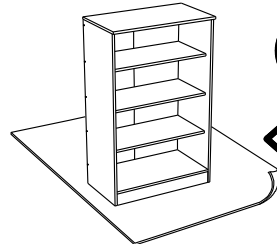
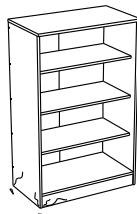
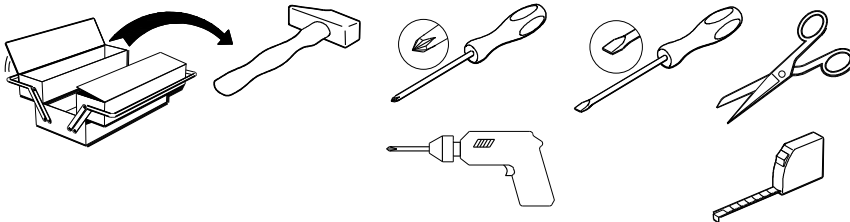

contact@pariset.com

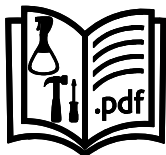

www.pariset.com

FR - NOTICE D'EMPLOI

IMPORTANT – LIRE ATTENTIVEMENT – A CONSERVER POUR RÉFÉRENCE ULTÉRIEURE

1. Utiliser les outils indiqués sur la notice de montage et suivre les instructions d'assemblage.
2. Il convient que tous les dispositifs d'assemblage soient toujours convenablement serrés et régulièrement vérifiés, ainsi que resserrés si nécessaire.
3. Le positionnement et le moyen d'accès au lit sont indiqués sur la notice de montage.
4. Respecter l'épaisseur maximale du matelas, voir le marquage sur la notice de montage.
5. Taille du matelas recommandé 1980 mm x 880 mm x 150 mm maximum.
6. Il convient de ne pas utiliser le lit surélevé lorsqu'une partie de la structure manque ou est cassée.
7. **AVERTISSEMENT:** Les lits surélevés ne conviennent pas aux enfants de moins de 6 ans, en raison des risques de blessures dues aux chutes.
8. Attention aux articles tels que des cordes, des ficelles, des cordons, des harnais et des ceintures attachés ou accrochés sur un lit superposé ou surélevé afin d'éviter aux enfants de s'étrangler.
9. **AVERTISSEMENT** «Les enfant peuvent se retrouver piégés entre le lit et le mur. Pour éviter le risque de blessure grave la distance entre la barrière de sécurité supérieure et le mur ne doit pas excéder 75 mm ou doit être d'au moins 230 mm»
10. Conforme à la norme européenne EN747-1 et EN747-2 de 2012.
11. Ne jamais laisser des enfants sans un minimum de surveillance.
12. Aucun jeu brutal ne doit être permis dans et sous le lit haut.
13. Il est interdit d'avoir plus d'une personne dans le lit haut.
14. Ne pas permettre aux enfants de se basculer ou de sauter sur ou sous le lit.
15. Utiliser toujours l'échelle pour monter ou descendre du lit haut.
16. Ne pas remplacer les pièces originales par des substitutions. Obtenir les pièces de rechange du magasin ou du fabricant.
17. L'utilisation d'une veilleuse de nuit peut procurer plus de sécurité à l'enfant couchant dans le lit haut.

EN - DIRECTIONS FOR USE

IMPORTANT – PLEASE READ CAREFULLY – KEEP FOR FUTURE REFERENCE

1. Use the tools indicated on the assembly leaflet and follow the instructions.
2. All assembly components must always be tightened properly. Check regularly and retighten if necessary.
3. The positioning and means of access to the bed are indicated on the assembly leaflet.
4. Do not exceed the maximum mattress thickness. Refer to the marking on the assembly leaflet.
5. Maximum recommended mattress size: 1980 mm x 880 mm x 150 mm
6. The high sleeper must not be used if a part of the structure is missing or broken.
7. **WARNING:** High sleepers are not suited to children below the age of 6 years due to the risk of injury in the event of a fall.
8. Do not attach or suspend items such as ropes, strings, cords, harnesses and belts on a bunk-bed or high sleeper to avoid the possibility of strangulation.
9. **WARNING:** Children may become trapped between the bed and the wall. To avoid the risk of serious injury, the distance between the top safety barrier and the wall must not exceed 75 mm or must be at least 230 mm.
10. Compliant with European Standard EN747-1 and EN747-2 of 2012.
11. Never leave children without a minimum of supervision.
12. Children must not be allowed to play roughly on or under the top bunk.
13. It is forbidden to have more than one person in the top bunk.
14. Do not allow children to swing or jump on or under the bed.
15. Always use the ladder to climb up to and down from the top bunk.
16. Do not replace original parts with substitutes. Spare parts must be obtained from the store or manufacturer.
17. Use of a night-light will improve safety for a child sleeping in the top bunk.

DE - GEBRAUCHSANWEISUNG

WICHTIG – AUFMERKSAM LESEN UND AUFBEWAHREN

1. Die in der Montage Anleitung angeführten Werkzeuge benutzen, die Montagehinweise beachten.
2. Alle Elemente müssen korrekt verbunden und angezogen (notfalls nachziehen) sein und regelmäßig überprüft werden.
3. Die Position und der Zugang zum Bett sind in der Montageanleitung aufgeführt.
4. Die maximale Stärke der Matratze einhalten, siehe die Markierungen in der Montageanleitung.
5. Empfohlene Abmessungen der zu Matratze 1980 mm x 880 mm x 150 mm maximal
6. Das Etagenbett darf nicht benutzt werden wenn die Struktur oder ein Teil der Struktur fehlt oder beschädigt ist.
7. **WARNUNG:** Die Etagenbetten sind nicht für Kinder unter 6 Jahren geeignet (Verletzungs- –und Unfallgefahr)
8. Vorsicht ist weiterhin geboten mit am Etagenbett befestigten Seilen, Kordeln, Bändern, oder Sicherheitsgeschirr, hier besteht Strangulierungsgefahr für Kinder.
9. **WARNUNG** « Kinder können sich zwischen dem Bett und der Wand eingeklemmt finden. Um Unfälle zu vermeiden, darf der Abstand zwischen der oberen Sicherheitsleiste und der Wand nicht mehr als 75 mm betragen oder muß wenigstens 230 mm betragen.
10. Entsprechend der europäischen Norm EN747-1 und EN747-2 von 2012.
11. Kinder niemals ohne ein Minimum von Aufsicht lassen.
12. Brutale Spiele dürfen in oder auf dem oberen Bett nicht zugelassen werden.
13. Im oberen Bett darf nur eine Person schlafen.
14. Die Kinder dürfen nicht auf das Bett springen oder schaukeln.
15. Nur die Leiter zum Hinaufsteigen und Herabsteigen des oberen Bettes benutzen.
16. Nur Originalteile bei Reparaturen verwenden. Die Austauschteile nur im Fachhandel oder beim Hersteller einkaufen.
17. Die Benutzung einer kleinen Lampe kann dem Kind im oberen Bett ein Sicherheitsgefühl verleihen.

ES - INSTRUCCIONES DE USO

IMPORTANTE – LEA ATENTAMENTE – CONSÉRVELAS PARA POSTERIORES CONSULTAS

1. Utilizar las herramientas indicadas en las instrucciones de montaje y seguir éstas últimas.
2. Es conveniente que todos los dispositivos de ensamblaje estén siempre adecuadamente apretados y periódicamente verificados, y vueltos a apretar si fuera necesario.
3. El posicionamiento y el medio de acceso a la cama vienen indicados en las instrucciones.
4. Respetar el grosor máximo del colchón, ver el marcado en las instrucciones de montaje.
5. Dimensiones del colchón recomendado 1980 mm x 880 mm x 150 mm máximo.
6. Será conveniente no utilizar la cama sobre elevada si una parte de la estructura faltara o estuviera rota
7. **ADVERTENCIA:** Las camas sobre elevadas no son aptas para los niños menores de 6 años, pues se pueden lesionar a causa de las caídas
8. Cuidado con los artículos tales como cuerdas, cordeles, arneses y cinturones atados o colgados en una cama superpuesta o sobre elevada para evitar que los niños se estrangulen.
9. **ADVERTENCIA** “los niños pueden verse pillados entre la cama y la pared. Para evitar el riesgo de lesiones graves, la distancia entre la barrera de seguridad superior y la pared no debe sobrepasar los 75 mm o debe ser de al menos 230 mm”
10. Conforme a la norma europea EN747-1 y EN747-2 de 2012.
11. No dejar nunca los niños sin un mínimo de vigilancia.
12. No se debe permitir ningún juego violento en la cama de arriba ni debajo de ésta.
13. Está prohibido que haya más de una persona en la cama de arriba.
14. No permitir a los niños voltearse o saltar encima o debajo de la cama.
15. Utilizar siempre la escalera para subir y bajar de la cama de arriba.
16. No sustituir las piezas originales por sustituciones. Pedir las piezas de repuesto dirigiéndose a la tienda o al fabricante.
17. La utilización de una lamparilla de noche puede proporcionar más seguridad al niño que se acuesta en la cama de arriba.

PT - INSTRUÇÕES

IMPORTANTE – LER ATENTAMENTE – GUARDAR PARA REFERÊNCIA POSTERIOR

1. Utilizar as ferramentas indicadas no folheto de montagem e seguir as instruções de montagem.
2. Todos os dispositivos de montagem devem estar correctamente apertados e verificados regularmente, se necessário apertar novamente.
3. O posicionamento e o meio de acesso à cama estão indicados no folheto de montagem.
4. Respeitar a espessura máxima do colchão, ver as especificações no folheto de montagem.
5. Tamanho do colchão recomendado 1980 mm x 880 mm x 150 mm no máximo.
6. Não deve utilizar a cama alta quando falta uma parte da estrutura ou quando esta está quebrada
7. AVISO: As camas altas não são adequadas para crianças com menos de 6 anos, devido aos riscos de ferimentos causados pelas quedas
8. Ter cuidado com os artigos tais como as cordas, fios, atacadores, arreios e cintos fixados ou atados numa cama alta ou beliche por forma a prevenir o risco de estrangulamento.
9. AVISO «As crianças podem ficar bloqueadas entre a cama e a parede. Para prevenir o risco de ferimentos graves, a distância entre a barreira de segurança superior e a parede não deve exceder 75 mm ou deve ser de pelo menos 230 mm»
10. Conforme à norma europeia EN747-1 e EN747-2 de 2012.
11. Nunca deixar as crianças sem vigilância
12. Nenhum jogo brutal deve ser permitido em cima e debaixo da cama alta.
13. É proibido haver mais de que uma pessoa na cama alta.
14. Não deixar as crianças empurrar-se ou saltar em cima ou debaixo da cama.
15. Utilizar sempre a escada para subir ou descer da cama alta.
16. Não substituir as peças de origem por outras peças. Obter as peças sobresselentes na loja ou no fabricante.
17. A utilização de um candeeiro pode trazer mais segurança à criança que dorme na cama alta.

IT - ISTRUZIONI PER L'USO

IMPORTANTE – LEGGERE ATTENTAMENTE – CONSERVARE PER FUTURA CONSULTAZIONE

1. Utilizzare gli utensili indicati sull'avviso di montaggio e seguire le istruzioni per l'assemblaggio.
2. È necessario che tutti i dispositivi di assemblaggio siano sempre opportunamente stretti e regolarmente controllati, nonché stretti nuovamente, se necessario.
3. La collocazione e il mezzo di accesso al letto sono indicati sull'avviso di montaggio.
4. Rispettare lo spessore massimo del materasso, facendo attenzione alla marchiatura sull'avviso di montaggio.
5. Misura consigliata di materasso 1980 mm x 880 mm x 150 mm massimo.
6. Si sconsiglia l'uso del lettino sopraelevato se una parte della struttura manca o è rotta.
7. AVVERTENZA: I lettini sopraelevati non sono adatti a bambini di età inferiore ai 6 anni, per i rischi di lesioni dovuti a cadute.
8. Attenzione agli articoli quali corde, spaghi, cordoni, imbracature o cinture fissate o appese a un letto sovrapposto o sopraelevato, per evitare che i bambini possano strangolarsi.
9. AVVERTENZA: "I bambini possono trovarsi intrappolati tra il letto ed il muro. Per evitare il rischio di gravi lesioni, la distanza tra la barriera di sicurezza superiore e il muro non deve superare i 75 mm o deve essere almeno di 230 mm".
10. Conforme alla norma europea EN747-1 e EN747-2 de 2012.
11. Non lasciare mai i bambini senza un minimo di sorveglianza.
12. Non permettere alcun gioco violento sul letto alto e al di sotto di esso.
13. È vietata la presenza di più di una persona sul letto in alto.
14. Non lasciare che i bambini si dondolino o che saltino sul letto o sotto di esso.
15. Per salire sul letto in alto o per scendere da esso, servirsi sempre della scaletta.
16. Non sostituire i componenti originali con parti non originali. Procurarsi i componenti di ricambio presso il magazzino o presso il produttore.
17. L'utilizzo di una luce notturna può offrire maggiore sicurezza al bambino che dorme sul letto in alto.

NL - GEBRUIKSAANWIJZING

BELANGRIJK – AANDACHTIG LEZEN – BEWAREN VOOR LATERE NASLAG

1. Gebruik het op de montagehandleiding aangegeven gereedschap en volg de assemblage-instructies.
2. Alle bevestigingsmiddelen van de assemblage moeten behoorlijk zijn vastgedraaid, regelmatig worden gecontroleerd en zonodig opnieuw worden aangehaald.
3. De plaatsing en de wijze van toegang tot het bed zijn op de montagehandleiding aangegeven.
4. Houd u aan de maximale matrasdikte, zie de markering op de montagehandleiding.
5. Aanbevolen matrasdikte: maximum 1980 mm x 880 mm x 150 mm .
6. Het hoge bed moet niet gebruikt worden, wanneer een deel van de structuur ontbreekt of kapot is.
7. WAARSCHUWING: Hoge bedden zijn niet geschikt voor kinderen onder de 6 jaar, vanwege het gevaar van verwondingen door vallen.
8. Wees voorzichtig met dingen als koorden, touwtjes, snoeren, tuigjes en gordels die vastgemaakt zijn aan een hoog bed, om te voorkomen dat kinderen gekeeld worden en stikken.
9. WAARSCHUWING «Kinderen kunnen klem raken tussen het bed en de muur. Om ernstige verwondingen te voorkomen, moet de afstand tussen de bovenste veiligheidsstang en de muur niet meer zijn dan 75 mm of minstens 230 mm»
10. Voldoet aan de Europese norm EN747-1 en EN747-2 van 2012.
11. Laat kinderen nooit alleen zonder minimale bewaking
12. Verbied woeste spellen in en onder een verhoogd bed.
13. Er mag zich maar één persoon tegelijk in het hoge bed bevinden.
14. Laat kinderen niet wippen of springen in of onder het hoge bed.
15. Gebruik altijd de ladder om in en uit het hoge bed te klimmen.
16. Vervang de originele stukken niet door namaak. Betrek de vervangende onderdelen van uw leverancier of van de fabrikant.
17. Het gebruik van een nachtlampje kan kinderen in een verhoogd bed een veilig gevoel geven.

CZ - Pokyny k používání

DŮLEŽITÉ - ČTĚTE POZORNĚ - USCHOVEJTE PRO BUDOUCÍ VYUŽITÍ

1. Používejte nástroje uvedené v návodu k montáži a dodržujte montážní pokyny.
2. Je vhodné, aby byly všechny montážní prvky vždy řádně utaženy a pravidelně kontrolovány a podle potřeby znovu utahovány.
3. Umístění a způsob přístupu k lůžku jsou uvedeny v montážním návodu.
4. Dodržujte maximální tloušťku matrace, viz značení na montážním pokynu.
5. Doporučený rozměr matrace je maximálně 1980 x 880 x 150.
6. Doporučujeme nepoužívat lůžko ve vyvýšené poloze, pokud je některá část konstrukce odstraněna nebo poškozena.
7. VÝSTRAHA : Vyvýšená lůžka nejsou vhodná pro děti ve věku do 6 let, a to z důvodu hrozících poranění při pádu.
8. Pozor na předměty, jako jsou lanka, nitě, kabely, popruhy a pásy připojené nebo umístěné na horním nebo vyvýšeném lůžku, aby nedošlo k poranění dětí.
9. VÝSTRAHA: „Může dojít k uvíznutí dětí mezi lůžkem a stěnou. Chcete-li předejít riziku vážného zranění, zajistěte maximální vzdálenost mezi horní bezpečnostní clonou a stěnou 75 mm nebo nejméně 230 mm“
10. Odpovídá evropské normě EN747-1 EN747-2 de 2012.
11. Nikdy nenechávejte děti bez minimálního dohledu.
12. V horním lůžku nebo pod ním je zakázána jakákoli brutální hra.
13. Na horním lůžku smí být pouze jedna osoba.
14. Nepovolte dětem, aby se houपालy nebo skákaly na lůžko nebo pod ně.
15. Pro výstup a sestup používejte jen žebřík.
16. Nevyměňujte originální díly za náhražky. Vyžádejte si náhradní díly z obchodu nebo od výrobce.
17. Používání dětské chůvičky může zajistit větší bezpečí dítěte, které spí na horním lůžku.

HU - Használati utasítás

FONTOS – OLVASSA EL FIGYELMESEN – ŐRIZZE MEG KÉSŐBBI MEGTEKINTÉS CÉLJÁRA

1. Az összeszerelési útmutatóban jelzett szerszámokat használja, és kövesse az összeállítási utasításokat.
2. Célszerű az összeállítás minden szerelékét mindig megfelelően meghúzni és rendszeresen ellenőrizni, valamint szükség esetén sor keríteni az újrahúzásukra.
3. Az ágy elhelyezését és megközelítésének módját az összeszerelési útmutató jelzi.
4. Tartsa tiszteletben a maximális matracvastagságot – ld. az összeszerelési mutatón található jelzést.
5. Az ajánlott matracméret legfeljebb 1980 x 880 x 150 mm.
6. A magasított ágyat nem célszerű használni, ha a szerkezet valamelyik része hiányzik vagy törött.
7. **FIGYELMEZTETÉS:** A magasított ágy 6 év alatti gyermekek nem használhatják, az esésből származó sérülések kockázata miatt.
8. Ügyeljen az olyan, az emeletes vagy magasított ágyhoz kötött vagy kapcsolt elemekre, mint a zsinórok, zsinogok, kötelek, hámok és övek, hogy elejét vegye a gyermekek megfulladásának.
9. **FIGYELMEZTETÉS:** „A gyermekek beszorulhatnak az ágy és a fal közé. A súlyos sérülés kockázatának elkerülésére a felső biztonsági korlát és a fal közötti távolság nem haladhatja meg a 75 mm-t vagy nagyobb kell, hogy legyen 230 mm-nél.”
10. Megfelel a 2012-es EN747-1 EN747-2. számú európai normának.
11. A gyermekeket soha ne hagyja teljesen felügyelet nélkül.
12. Semmilyen heves játékot nem szabad megengedni a felső ágyban és alatta.
13. A felső ágyban tilos egynél több személynek tartózkodnia.
14. Ne engedje meg a gyermekeknek, hogy az ágyra vagy az ágy alatt lökdösődjenek vagy ugráljanak.
15. A felső ágyba való feljutáshoz és az onnan való lejutáshoz mindig a létrát használja.
16. Az eredeti alkatrészeket ne cserélje helyettesítő alkatrészekre. A cserealkatrészeket az üzletből vagy a gyártótól szerezze be.
17. Az éjszakai jelzőfény használata nagyobb biztonságot nyújthat a felső ágyban fekvő gyermeknek.

PL - Instrukcja obsługi

WAŻNE – PRZECZYTAĆ UWAŻNIE – ZACHOWAĆ DO PÓZNIJSZEGO SKORZYSTANIA

1. Używać narzędzi podanych w instrukcji montażu i stosować się do sposobu montażu podanego w instrukcji.
2. Wszystkie mocowania muszą być odpowiednio dokręcone, regularnie sprawdzane, a w razie potrzeby ponownie dokręcane.
3. Lokalizacja dostępu i jego sposób są podane w instrukcji montażu.
4. Przestrzegać minimalnej grubości materaca – patrz znakowanie w instrukcji montażu.
5. Zalecane maksymalne wymiary materaca: 1980 × 880 × 150 mm.
6. Nie należy używać łózka piętrowego, gdy brakuje jakiegokolwiek elementu konstrukcji lub jest on złamany.
7. **OSTRZEŻENIE:** Łóżka piętrowe nie nadają się dla dzieci w wieku poniżej 6 lat, ponieważ zagrażają obrażeniami wywołanymi upadkami.
8. Należy zwracać uwagę na przedmioty takie jak liny, sznurki, linki, uprząże i paski zamocowane do łózka piętrowego — mogą one doprowadzić do uduszenia się dziecka.
9. **OSTRZEŻENIE:** „Dzieci mogą wpaść między łóżko i ścianę. Aby uniknąć ryzyka poważnych obrażeń, odległość górnej bariery ochronnej od ściany nie powinna przekraczać 75 mm lub powinna wynosić co najmniej 230 mm.”
10. Wyrób zgodny z normą europejską EN747-1 EN747-2 z roku 2012.
11. Nigdy nie pozostawiać dzieci bez minimalnego nadzoru.
12. Na łóżku górnym niedozwolone są żadne gwałtowne zabawy.
13. Na łóżku górnym może przebywać tylko jedna osoba.
14. Nie pozwalaj dzieciom na kołysanie się ani skakanie na łóżko i z łózka.
15. Do wchodzenia na łóżko górne i schodzenia zeń zawsze używać drabinki.
16. Nie wymieniać części oryginalnych na zamienniki. Oryginalne części zamienne można nabyć w sklepie lub u producenta.
17. Lampka nocna może zapewnić większe bezpieczeństwo dziecku śpiącemu w łóżku górnym.

RO - Instrucțiuni de utilizare

IMPORTANT – CITIȚI CU ATENȚIE – PĂSTRAȚI INSTRUCȚIUNILE PENTRU O CONSULTARE ULTERIOARĂ

1. Utilizați uneltele indicate în instrucțiunile de montare și respectați instrucțiunile de asamblare.
2. Este indicat ca toate dispozitivele de asamblare să fie întotdeauna strânse în mod corespunzător și verificate cu regularitate, precum și să fie strânse din nou, dacă este necesar.
3. Poziționarea și mijlocul de acces la pat sunt indicate în instrucțiunile de montare.
4. Respectați grosimea maximă a saltelei, ținând cont de marcajul din instrucțiunile de montaj.
5. Dimensiunea recomandată a saltelei trebuie să fie de maxim 1980 x 880 x 150.
6. Este indicat să nu utilizați patul supraetajat atunci când o parte din structură lipsește sau s-a rupt.
7. **AVERTISMENT:** Paturile supraetajate nu sunt adecvate pentru copii cu vârsta sub 6 ani, din cauza riscurilor de vătămare datorată căderilor.
8. Atenție la articole precum corzi, sfori, cordoane, hamuri și centuri atașate sau agățate de un pat suprapus sau supraetajat, pentru a evita pericolul de strangulare a copiilor.
9. **AVERTISMENT:** „Copiii pot rămâne prinși între pat și perete. Pentru a evita riscul de rănire gravă, distanța dintre bariera de securitate superioară și perete nu trebuie să depășească 75 mm sau trebuie să fie de cel puțin 230 mm.”
10. Conform cu standardul european EN747-1 EN747-2 din 2012.
11. Nu lăsați niciodată copiii nesupravegheați la un nivel minim.
12. Niciun joc brutal nu trebuie permis în și sub patul de sus.
13. Este interzis să stea mai multe persoane în patul de sus.
14. Nu permiteți copiilor să se leagne sau să sară pe sau sub pat.
15. Utilizați întotdeauna scara pentru a urca sau coborî din patul de sus.
16. Nu înlocuiți piesele originale cu alte piese. Obțineți piesele de schimb de la magazin sau de la producător.
17. Utilizarea unei veioze de noapte poate oferi un grad sporit de siguranță copilului care doarme în patul de sus.

RU - Инструкция по использованию

ВАЖНО – ЧИТАТЬ ВНИМАТЕЛЬНО – СОХРАНИТЬ ДЛЯ ПОСЛЕДУЮЩЕГО ОЗНАКОМЛЕНИЯ

1. Используйте инструменты, приведенные в руководстве по монтажу, и следуйте инструкциям по сборке
2. Все сборные части всегда должны быть должным образом затянуты и подлежат проверке на регулярной основе, также при необходимости следует производить дополнительную затяжку.
3. Местоположение и способ доступа к кровати указаны в руководстве по монтажу.
4. Соблюдайте максимальную толщину матраса, см. маркировку в руководстве по монтажу.
5. Рекомендованный размер матраса – не более 1980 x 880 x 150
6. Не следует использовать одноярусную приподнятую кровать, если часть конструкции сломана или повреждена
7. **ПРЕДУПРЕЖДЕНИЕ:** Одноярусные приподнятые кровати не подходят детям до 6 лет в связи с угрозой травм при падении
8. Обратите внимание на такие детали, как веревки, шнуры, застежки, пояса и ремни, привязанные или прикрепленные к двухъярусной или одноярусной кровати.
9. **ПРЕДУПРЕЖДЕНИЕ:** «Дети могут оказаться зажатыми между кроватью и стеной. Во избежание риска серьезных травм, расстояние между верхним защитным барьером и стеной не должно превышать 75 мм или должно составлять как минимум 230 мм».
10. Соответствует европейской норме EN747-1 EN747-2 от 2012 г.
11. Никогда не оставляйте детей без надзора.
12. Никакие активные игры не могут быть разрешены на верхнем ярусе кровати и под ним.
13. Запрещено нахождение более одного лица на верхнем ярусе кровати.
14. Не разрешайте детям раскачиваться или прыгать на кровати, или под ней.
15. Всегда используйте лестницу, чтобы подняться на верхний ярус кровати, или спуститься с него.
16. Не заменяйте оригинальные детали неоригинальными. Заказывайте запасные детали в магазине или у производителя.
17. Использование ночного светильника может обеспечить больше безопасности для ребенка, спящего на верхнем ярусе кровати.

SK - Pokyny týkajúce sa použitia

DÔLEŽITÉ – PREČÍTAJTE SI POZORNE – USCHOVAJTE PRE PRÍPAD POTREBY

1. Použite nástroje uvedené v montážnom návode a postupujte podľa montážnych pokynov.
2. Všetky montážne prvky musia byť vždy náležite utiahnuté a je nutné ich pravidelne kontrolovať a v prípade potreby utiahnuť.
3. Poloha jednotlivých dielov a umiestnenie prístupu na posteľ sú uvedené v montážnom návode.
4. Dodržiavajte maximálnu hrúbku matracu – pozrite si údaje uvedené v montážnom návode.
5. Odporúčaná maximálna hrúbka matracu je 1 980 x 880 x 150 mm.
6. Zvýšenú posteľ nepoužívajte, ak chýba časť jej konštrukcie alebo ak je niektorý diel zlomený.
7. UPOZORNENIE: Zvýšené postele nie sú vhodné pre deti mladšie ako 6 rokov kvôli riziku poranenia spôsobeného pádom.
8. Pozor na predmety, ako sú laná, špagáty, šnúry, postroje a remene upevnené alebo zavesené na poschodovej resp. zvýšenej posteli, keďže pre deti predstavujú nebezpečenstvo uskrtenia.
9. UPOZORNENIE: „Deti sa môžu zakliesniť do medzery medzi konštrukciou postele a stenou. Aby ste predišli riziku vážneho poranenia, vzdialenosť medzi hornou bezpečnostnou zábranou a stenou nesmie byť väčšia ako 75 mm alebo musí byť aspoň 230 mm.“
10. Výrobok spĺňa požiadavky európskej normy EN747-1 EN747-2 z roku 2012.
11. Deti nikdy nenechávajte úplne bez dozoru.
12. V žiadnom prípade nedovoľte, aby sa deti hrubým spôsobom hrali v hornej posteli alebo pod hornou posteľou.
13. V hornej posteli nesmie byť viac ako jedna osoba.
14. Nedovoľte deťom, aby sa hojdali na posteli, alebo aby skákali na posteľ resp. pod posteľ.
15. Na vychádzanie a schádzanie do/z hornej postele používajte vždy rebrík.
16. Nikdy nevymieňajte originálne diely za náhrady. Originálne náhradné diely si môžete zakúpiť v obchode alebo u výrobcu.
17. Používanie nočného svetielka môže dieťaťu spiacemu v hornej posteli poskytnúť pocit väčšieho bezpečia.

TR - Kullanım talimatları

ÖNEMLİ – DİKKATLE OKUYUN – DAHA SONRAKİ KULLANIMLAR İÇİN SAKLAYIN

1. Montaj kılavuzunda belirtilen aletleri kullanın ve montaj talimatlarına uyun.
2. Montaj düzeneklerinin her zaman uygun şekilde sıkılmış, düzenli olarak kontrol edilmiş ve gerekiyorsa yeniden sıkılmış olması uygun olacaktır.
3. Yatağın konumu ve yatağa erişim yolu montaj kılavuzunda belirtilmiştir.
4. Somyanın maksimum kalınlığına uyunuz, montaj kılavuzundaki işarete bakınız.
5. Tavsiye edilen somya boyutu maksimum 1980 x 880 x 150'dir.
6. Yapının bir kısmı eksikse veya kırılmışsa tekli ranzanın kullanılmaması uygun olacaktır.
7. UYARI – Tekli ranzalar, düşme nedeniyle oluşabilecek yaralanmalar sebebiyle 6 yaşından küçük çocuklar için uygun değildir.
8. Çocukların boğulmasını önlemek amacıyla, tekli veya ikili ranzaya bağlı veya yataktan sallanan ip, sicim, kordon, kayış, kemer gibi malzemelere dikkat edin.
9. UYARI – “Çocuklar yatakla duvar arasına sıkışabilir. Ciddi yaralanma riskinin önüne geçmek amacıyla üst güvenlik bariyeri ile duvar arasındaki mesafe 75 mm'yi geçmemeli veya 230 mm'den az olmamalıdır.”
10. 2012 yılına ait EN747-1 EN747-2 Avrupa normuna uygundur.
11. Çocukları asla gözetimsiz bırakmayın.
12. Üst yatakta ve altında şiddetli oyunlara izin verilmemelidir.
13. Üst yatakta birden fazla kişinin bulunması yasaktır.
14. Çocuklarınızın yatakta veya yatak altında yuvarlanmalarına veya yatağa atmalarına izin vermeyin.
15. Üst yatağa çıkarken veya yataktan inerken daima merdiveni kullanın.
16. Orijinal parçaları asla benzerleriyle değiştirmeyin. Mağaza veya üreticiden yedek parçaları tedarik edin.
17. Gece lambası kullanımı, üst yatakta uyuyan çocuk için daha fazla güvenlik sağlayabilir.

AR - تعليمات الاستخدام

هام- يجب قراءتها باهتمام- والاحتفاظ بها للرجوع إليها لاحقا

- 1- استخدم الأدوات المحددة في نشرة التركيب والتزم باتباع تعليمات التجميع.
- 2- يفضل الاحتفاظ بجميع معدات التجميع مربوطة جيدا مع فحصها بشكل دوري، وإعادة ربطها مرة أخرى إذا لزم الأمر.
- 3- طريقة ضبط موضع السرير وكيفية الوصول للسرير موضحان في نشرة التركيب.
- 4- يجب الالتزام بالتخانة القصوى للمرتبة والنظر للعلامة الموضحة في نشرة التركيب.
- 5- الأبعاد المثالية للمرتبة 1980 x 880 x 150 كحد أقصى.
- 6- يفضل عدم استخدام السرير العلوي إذا كان جزء من الهيكل مفقودا أو مكسورا.
- 7- الأسرة المرفوعة لا تناسب الأطفال الذي يقل عمرهم عن ستة أعوام، نظرا لما قد يصيبهم من كسور نتيجة السقوط والارتطام.
- 8- يجب الحذر من بعض الأشياء مثل الحبال والخيوط والأسلاك والأطواق والأحزمة المشبوكة أو المعلقة على سرير تم رفعه أو تعليته وذلك لتجنب اختناق الأطفال.
- 9- تحذير "يمكن للأطفال أن يجسوا بين السرير والحائط. وتجنب خطر الإصابة البالغة، يجب ألا تزيد المسافة بين حاجز الأمان العلوي وبين الحائط عن 75 مم أو أن تكون على الأقل 230 مم".
- 10- يتوافق مع المعيار الأوروبي EN747-1-2 EN747 لعام 2012.
- 11- لا تدع الأطفال وحدهم أبدا بدون حد أدنى من الإشراف.
- 12- لا يسمح باللعب بأي لعبة غليظة داخل السرير العالي أو تحت منه.
- 13- يحظر تماما نوم أكثر من شخص واحد على السرير العلوي.
- 14- لا يسمح للأطفال أن يتدافعوا أو أن يقفزوا فوق أو تحت السرير.
- 15- يجب دائما استخدام السلالم للصعود أو النزول من السرير العلوي.
- 16- لا تستبدل أبدا الأجزاء الأصلية بأخرى تحل محلها. ويمكن الحصول على قطع الغيار من المتجر أو من المصنع.
- 17- استخدام مصباح صغير أثناء النوم قد يجلب للطفل المزيد من الشعور بالأمان أثناء النوم في السرير العلوي.

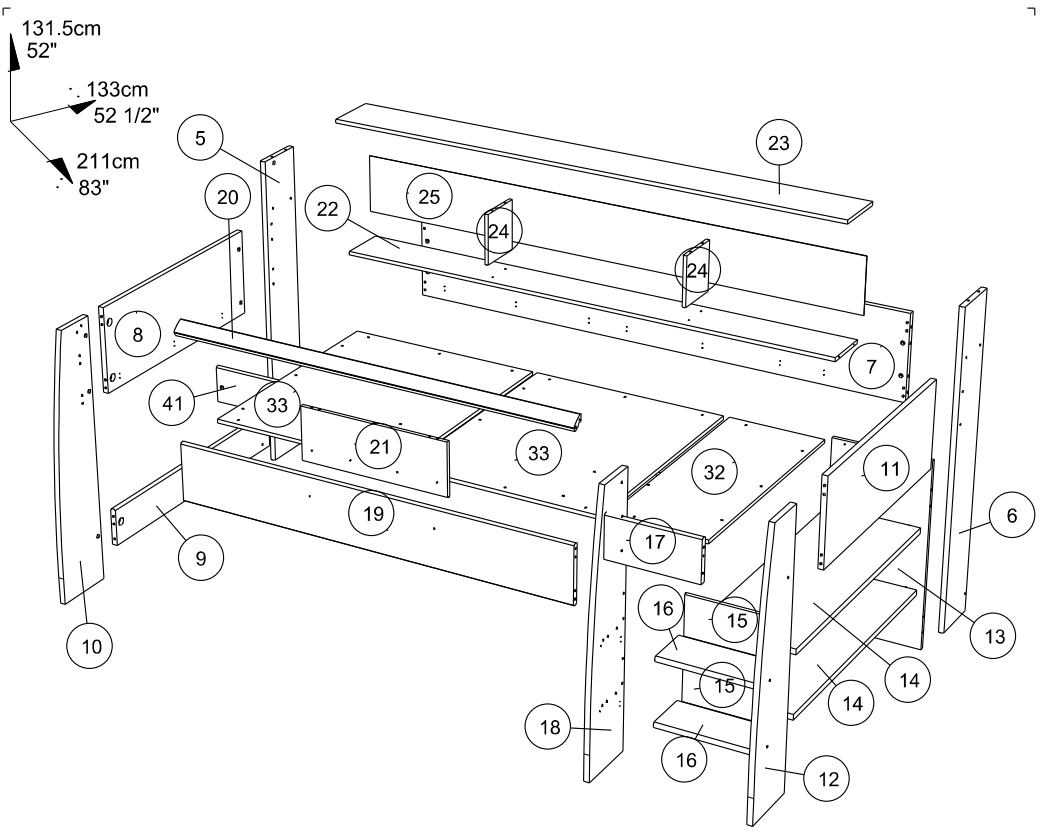

		inch	
		7 15/16	7 1/4
		14 3/8	6 5/16
		14 3/8	6 3/4
		14 3/8	6 3/4
		23 7/16	8 3/8
		30 1/16	15 7/16
		35 7/16	13 11/16
		35 7/16	13 11/16
		36 3/8	15 1/16
		37 1/4	30 13/16
		40 13/16	14 3/8
		40 7/8	6
		42 11/16	9 1/2
		42 11/16	9 1/2
		42 11/16	9 1/2
		51 3/16	8 1/8
		51 3/16	8 1/8
		63 1/2	2 5/16
		63 1/2	9 5/16
		80 1/2	6 1/8
		80 1/2	7 7/16
		80 1/2	13 3/4
		83	8 3/8
		82 1/16	9
mm			
		202	184
		365	160
		365	171
		365	171
		595	212
		763	392
		900	347
		900	347
		924	382
		946	782
		1037	365
		1038	153
		1085	242
		1085	242
		1085	242
		1300	206
		1300	206
		1613	58
		1613	236
		2044	155
		2044	189
		2044	350
		2108	212
		2084	228
		inch	
		7 15/16	7 1/4
		14 3/8	6 5/16
		14 3/8	6 3/4
		14 3/8	6 3/4
		23 7/16	8 3/8
		30 1/16	15 7/16
		35 7/16	13 11/16
		35 7/16	13 11/16
		36 3/8	15 1/16
		37 1/4	30 13/16
		40 13/16	14 3/8
		40 7/8	6
		42 11/16	9 1/2
		42 11/16	9 1/2
		42 11/16	9 1/2
		51 3/16	8 1/8
		51 3/16	8 1/8
		63 1/2	2 5/16
		63 1/2	9 5/16
		80 1/2	6 1/8
		80 1/2	7 7/16
		80 1/2	13 3/4
		83	8 3/8
		82 1/16	9
		mm	
		202	184
		365	160
		365	171
		365	171
		595	212
		763	392
		900	347
		900	347
		924	382
		946	782
		1037	365
		1038	153
		1085	242
		1085	242
		1085	242
		1300	206
		1300	206
		1613	58
		1613	236
		2044	155
		2044	189
		2044	350
		2108	212
		2084	228
		inch	
		7 15/16	7 1/4
		14 3/8	6 5/16
		14 3/8	6 3/4
		14 3/8	6 3/4
		23 7/16	8 3/8
		30 1/16	15 7/16
		35 7/16	13 11/16
		35 7/16	13 11/16
		36 3/8	15 1/16
		37 1/4	30 13/16
		40 13/16	14 3/8
		40 7/8	6
		42 11/16	9 1/2
		42 11/16	9 1/2
		42 11/16	9 1/2
		51 3/16	8 1/8
		51 3/16	8 1/8
		63 1/2	2 5/16
		63 1/2	9 5/16
		80 1/2	6 1/8
		80 1/2	7 7/16
		80 1/2	13 3/4
		83	8 3/8
		82 1/16	9
		mm	
		202	184
		365	160
		365	171
		365	171
		595	212
		763	392
		900	347
		900	347
		924	382
		946	782
		1037	365
		1038	153
		1085	242
		1085	242
		1085	242
		1300	206
		1300	206
		1613	58
		1613	236
		2044	155
		2044	189
		2044	350
		2108	212
		2084	228

		mm			inch		
34	x 2	497	368	15	19 9/16	14 1/2	9/16
29	x 1	757	326	15	29 13/16	12 13/16	9/16
30	x 1	757	350	15	29 13/16	13 3/4	9/16
27	x 1	1001	155	15	39 7/16	6 1/8	9/16
28	x 1	1001	322	15	39 7/16	12 11/16	9/16
26	x 1	1001	324	22	39 7/16	12 3/4	7/8
31	x 1	1017	730	3	40 1/16	28 3/4	1/8

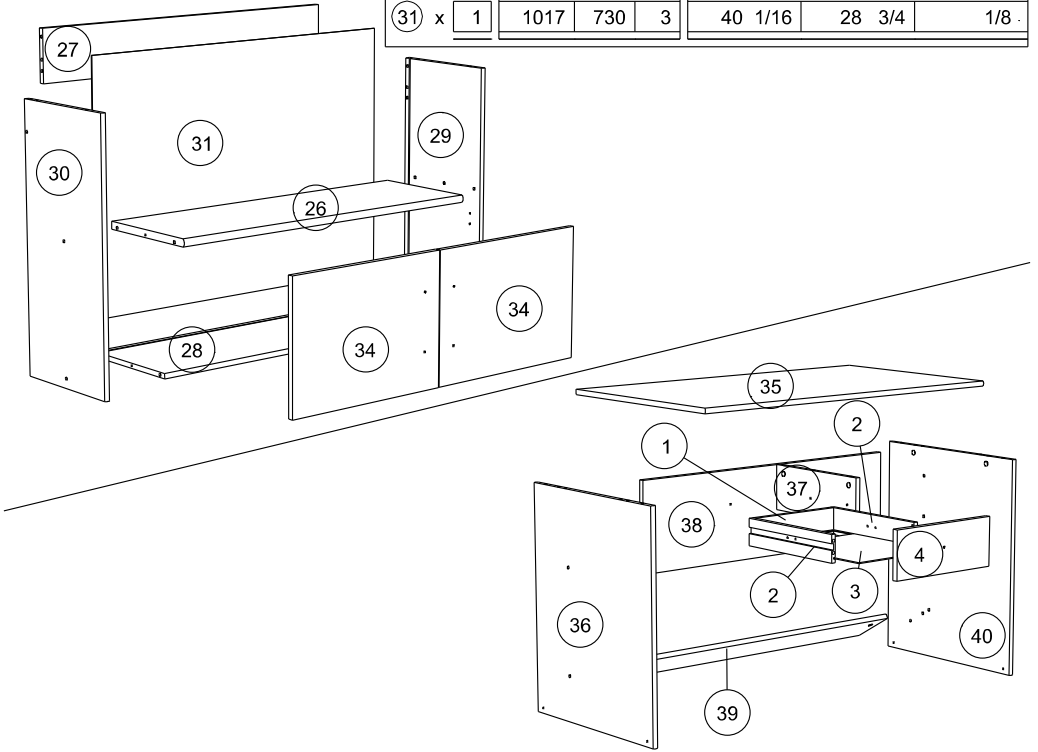

		mm			inch		
4	x 1	322	130	15	12 11/16	5 1/8	9/16
37	x 1	350	134	15	13 3/4	5 1/4	9/16
36	x 1	658	546	15	25 7/8	21 1/2	9/16
40	x 1	658	546	15	25 7/8	21 1/2	9/16
39	x 1	902	150	15	35 1/2	5 7/8	9/16
38	x 1	902	269	15	35 1/2	10 9/16	9/16
35	x 1	1030	592	15	40 9/16	23 5/16	9/16
2	x 2	335	75	13	13 3/16	2 15/16	1/2
1	x 1	276	75	13	10 7/8	2 15/16	1/2
3	x 1	334	286	3	13 1/8	11 1/4	1/8

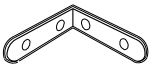

LN x 28



EP x 2



VW x 5



BML x 26

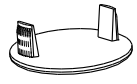

ADP x 5

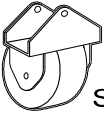

SD x 4



AKG x 4



Ai x 14

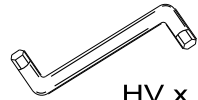

HV x 1



BAG x 4



NZ x 1



WA x 6

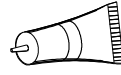

CF x 4

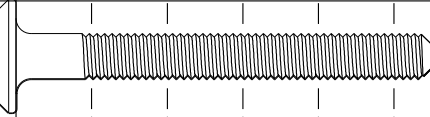
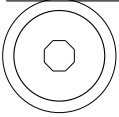
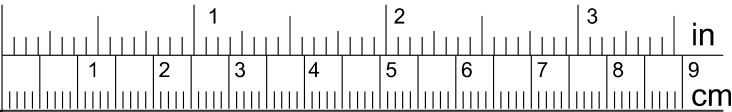

BLZ x 28

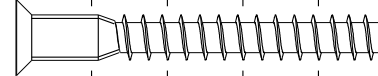

HW x 16

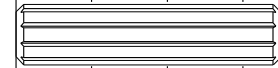

AP x 46



ADM x 40



ADU x 4

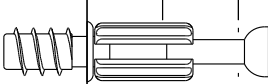

BSD x 14

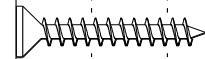
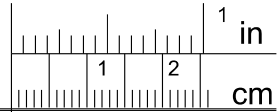

VJ x 8

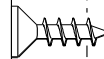

VG x 16

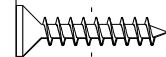

WJ x 64



VR x 26



BOU x1



POi x2

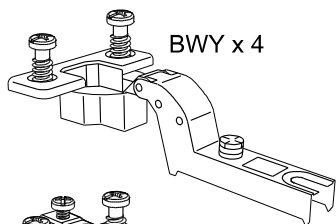
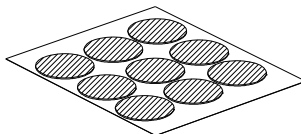

BWY x 4

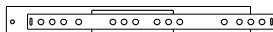

Ci x2

BRC x2

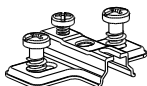

BWU x4

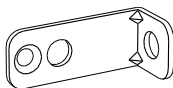

BLL x 2

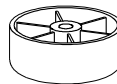

BXC x 1



AHX x 33

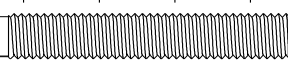
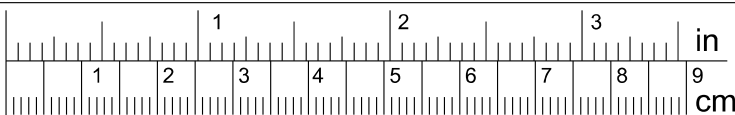

VV x 5



APU x 2



WZ x 7

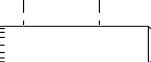
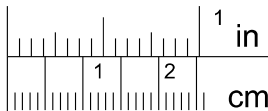

PP x 2

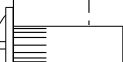

AKJ x 24

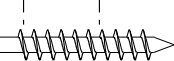

WH x 9

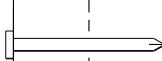

YB x 22

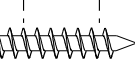

XN x 1

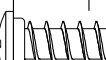

VB x 4



ANK x 4

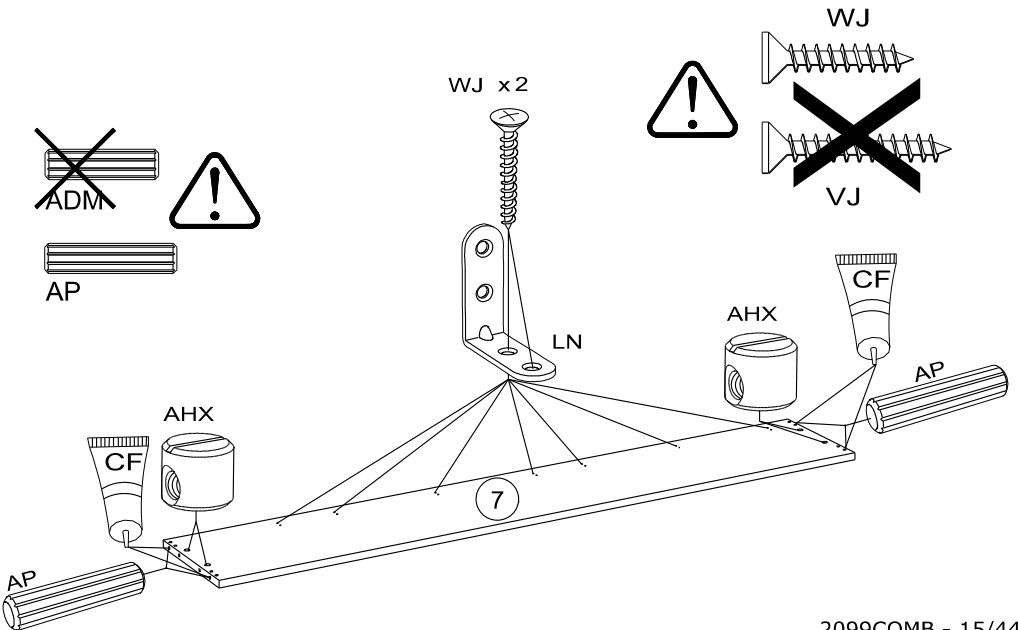
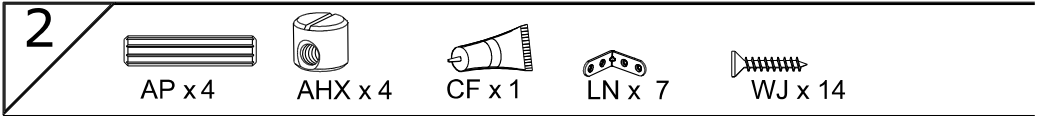
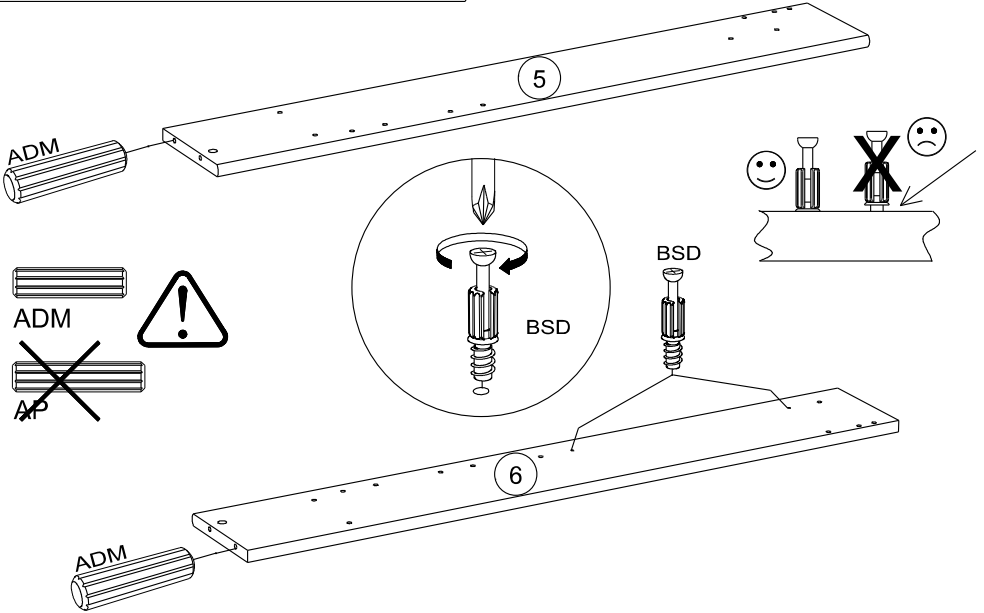
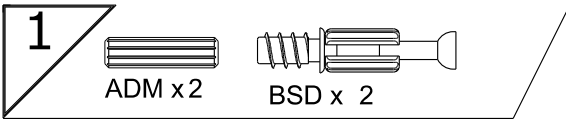

3



AP x 10



AHX x 7



LN x 3



WJ x 6



VV x 3

WJ x 2



ADM



AP

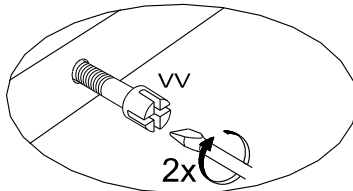
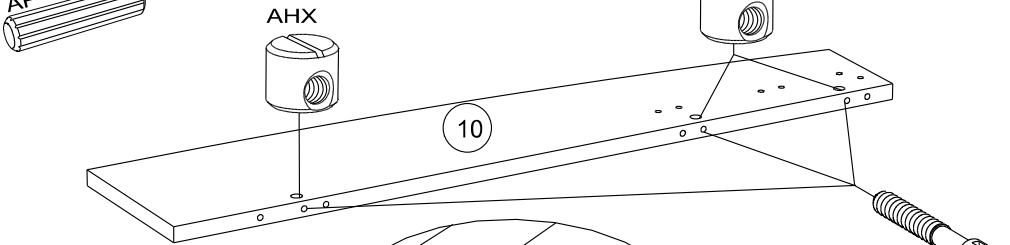
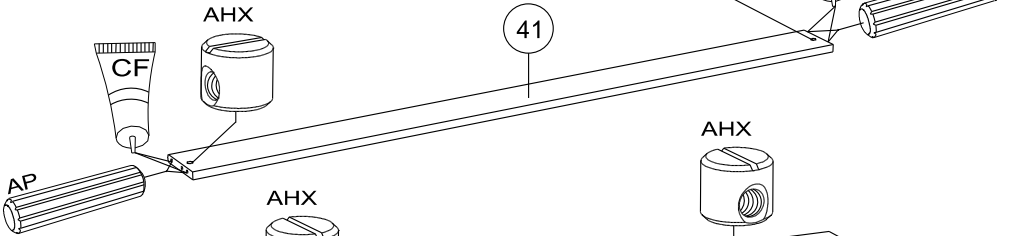
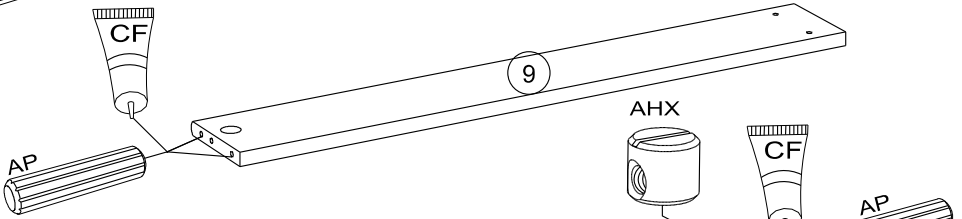
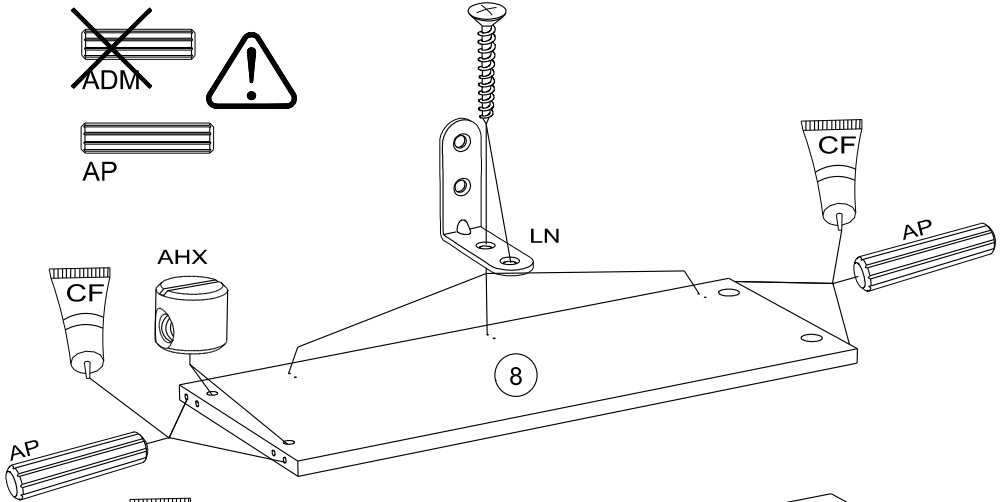

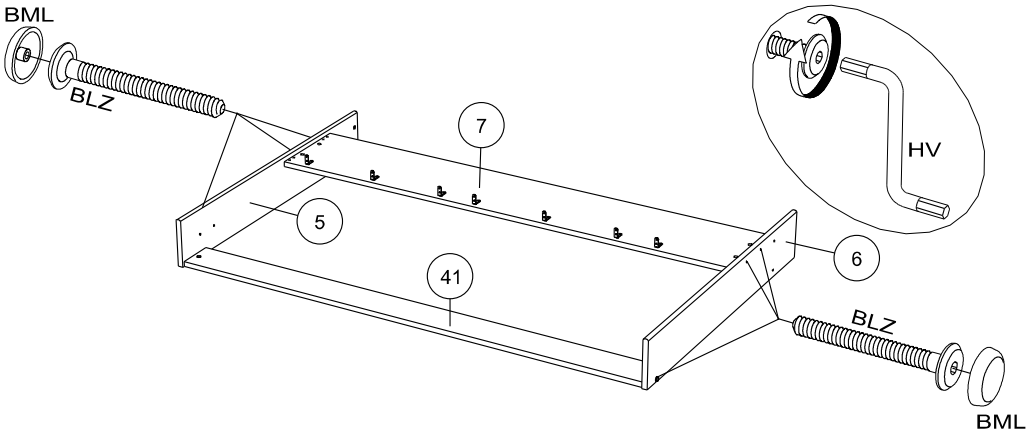
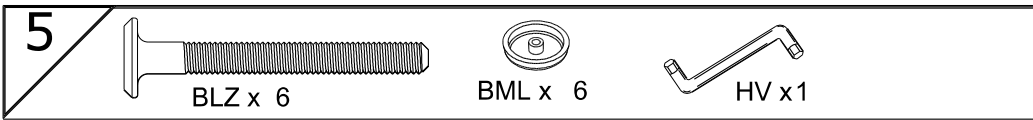
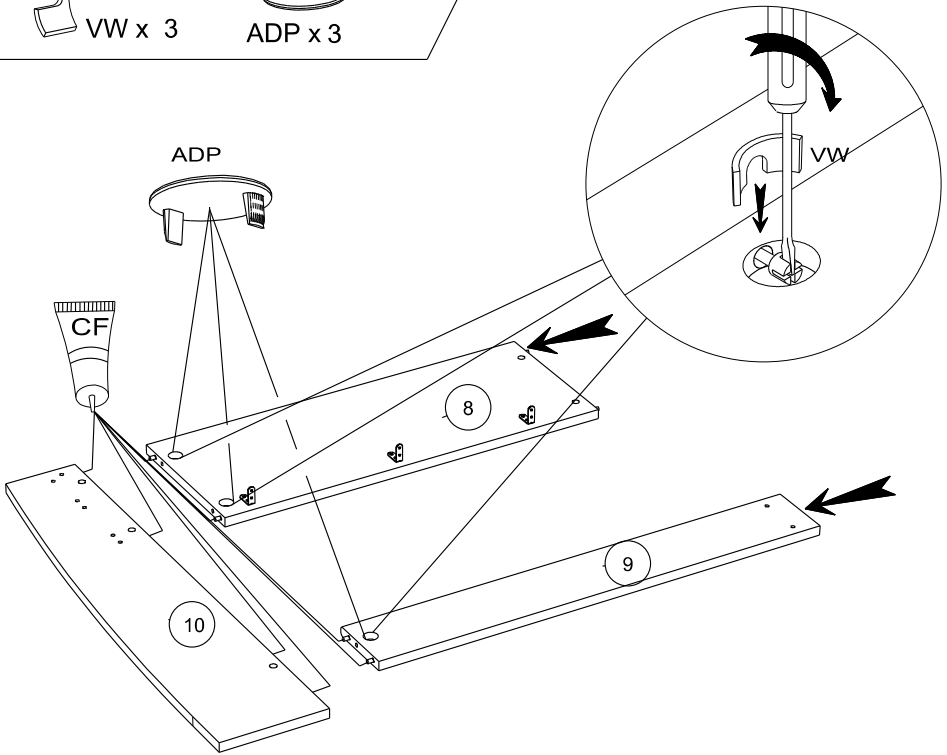
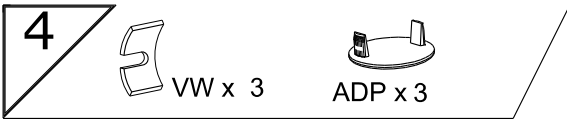

6

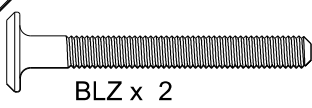

BLZ x 2



BML x 4



AKG x 4



APU x 2

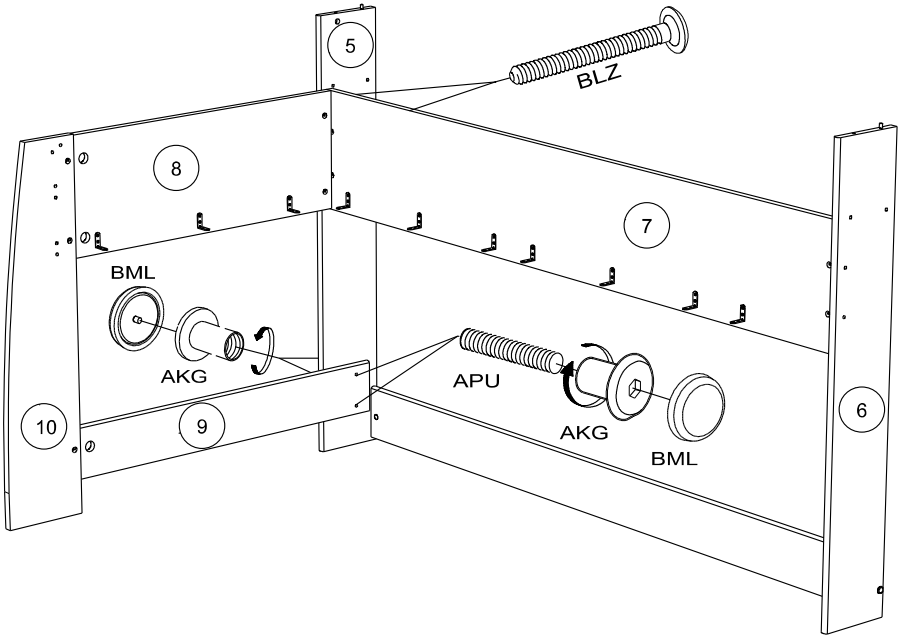

7



AP x 4



AHX x 2



LN x 3



WJ x 6

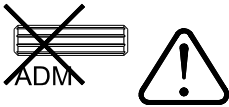

AP

WJ x 2

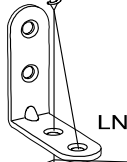

LN

AHX



11

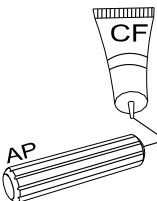

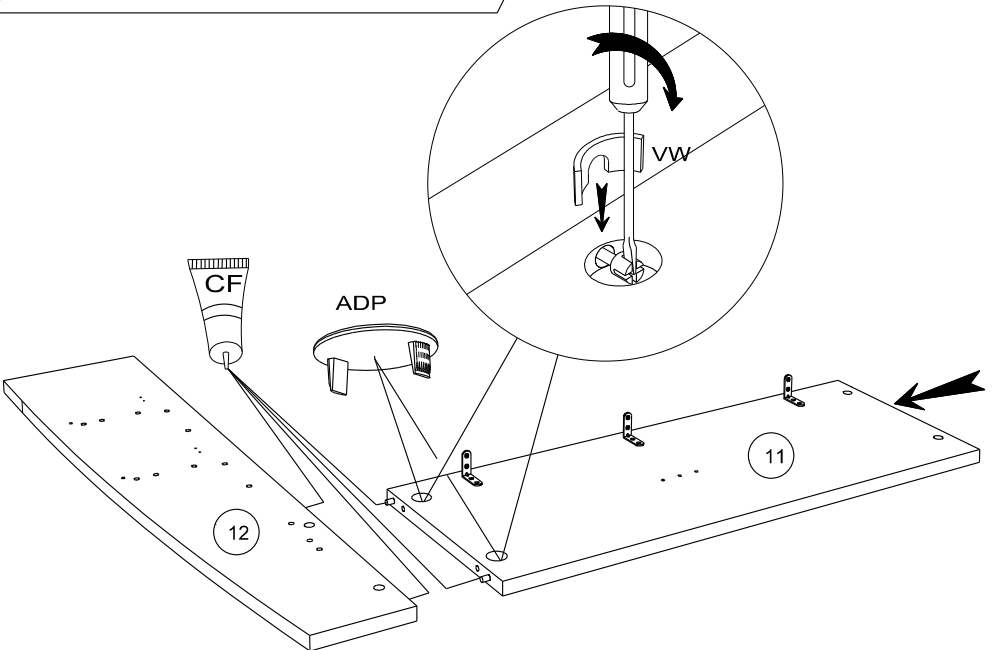
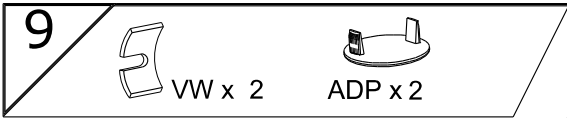
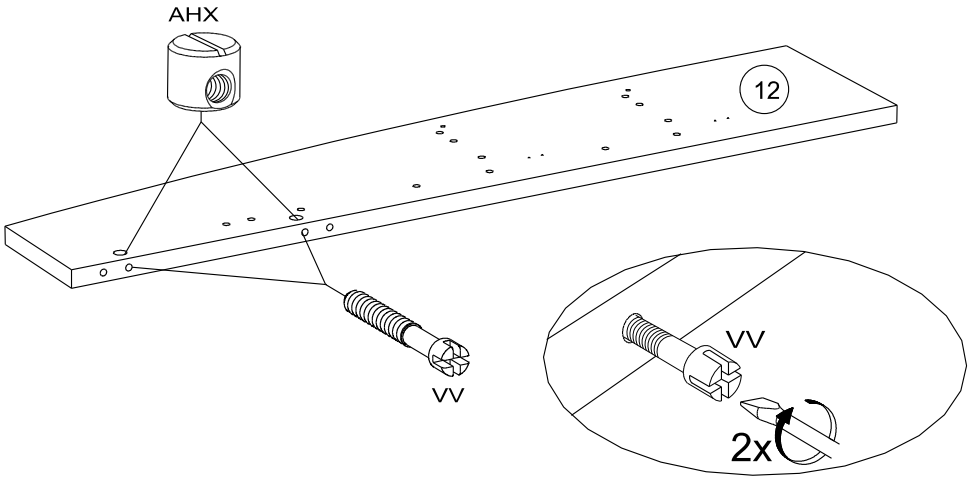
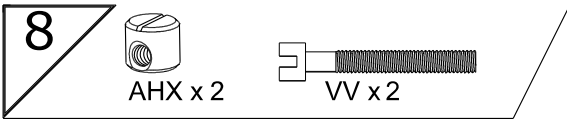

10

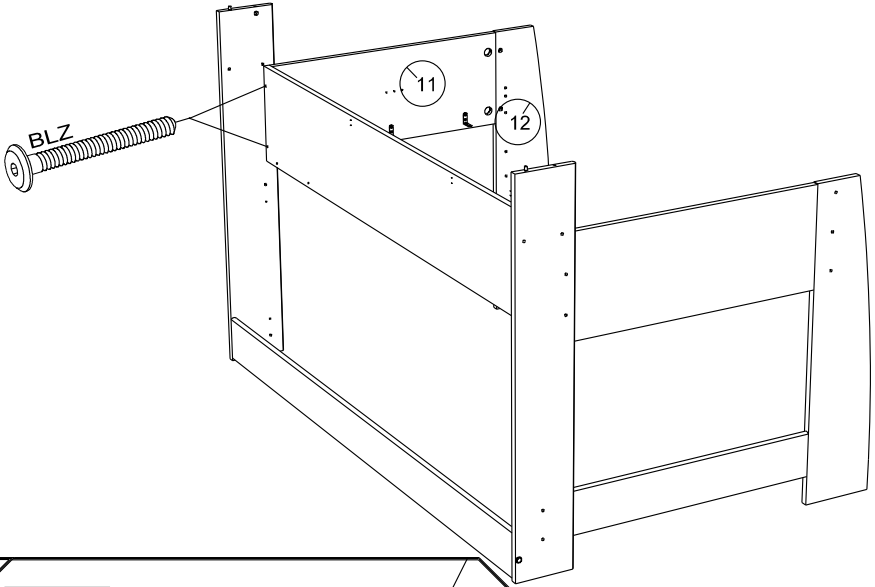
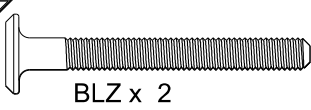

11

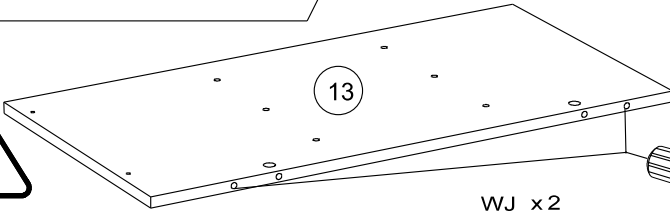

WJ x 2

WJ x 2

WJ x 2

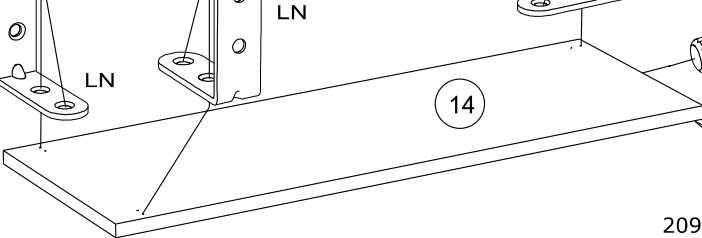
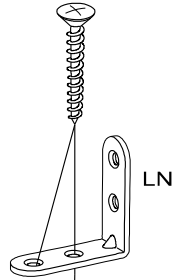
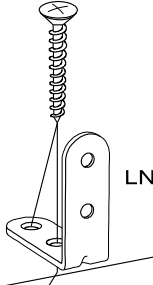
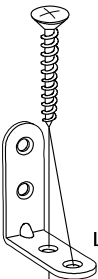

x2

12



Ai x2

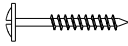

WH x 2

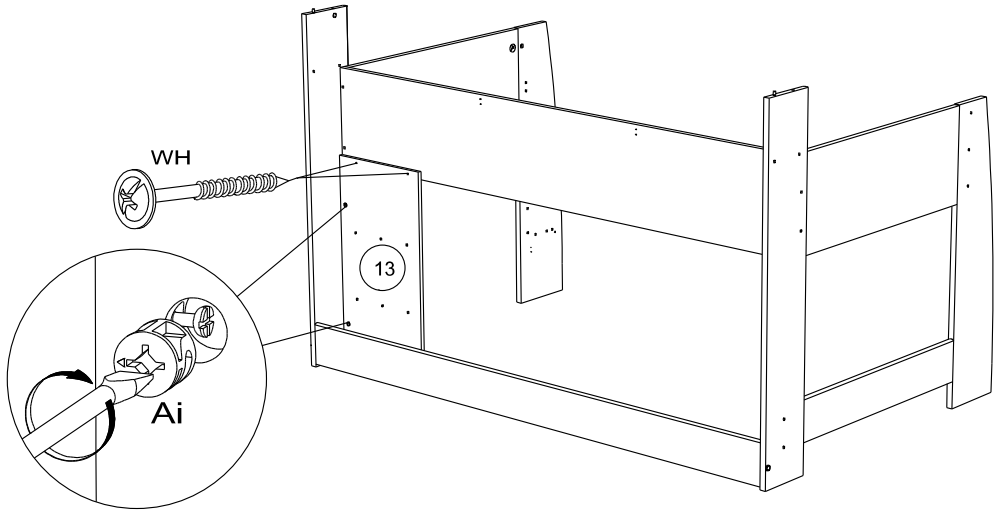

13

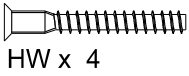

HW x 4



WJ x 4



VG x 4

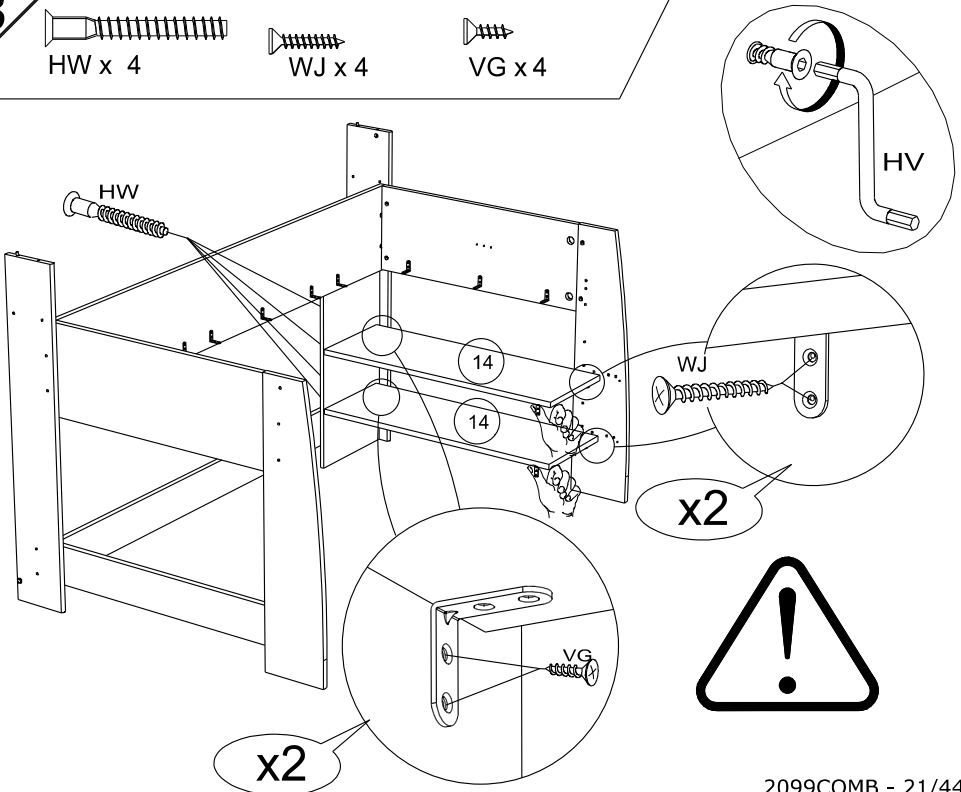

14

ADM x 8

AP x 12

AHX x 6

LN x 1

WJ x 2

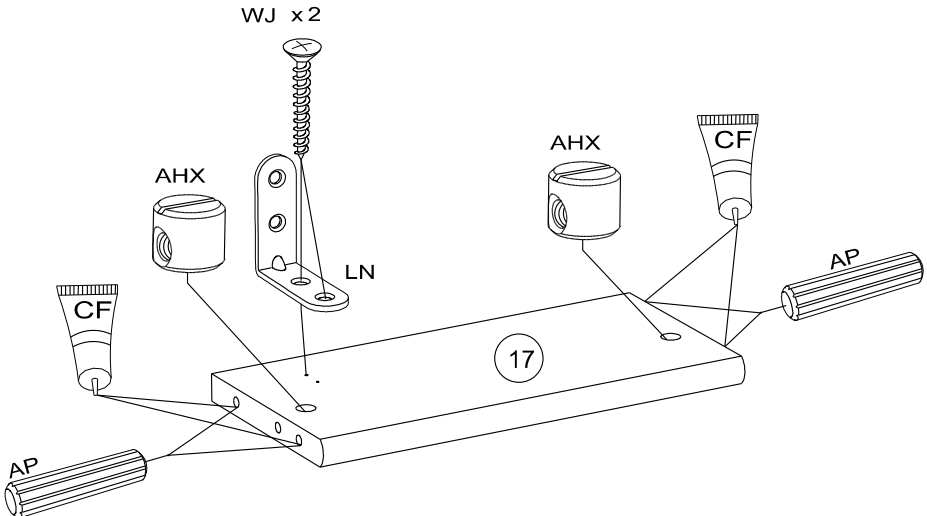
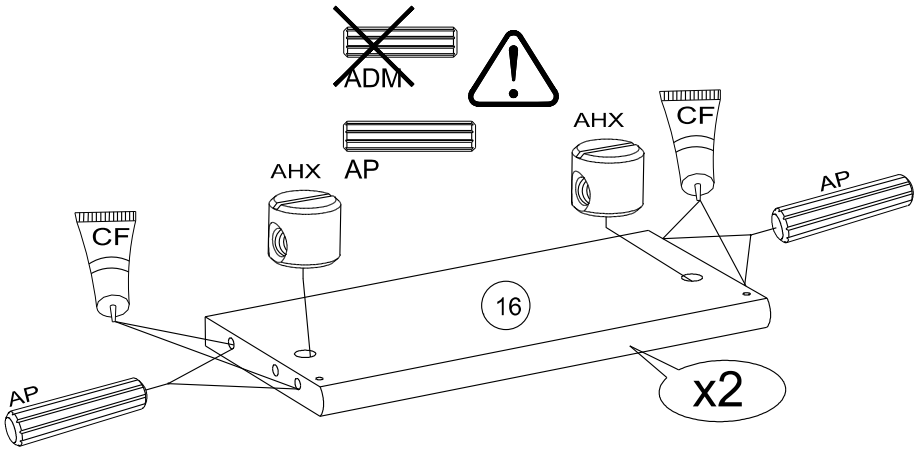
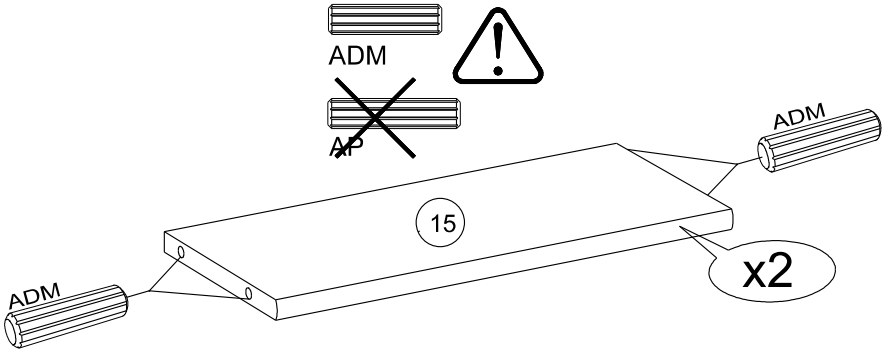

15

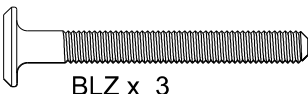

BLZ x 3



BML x 3

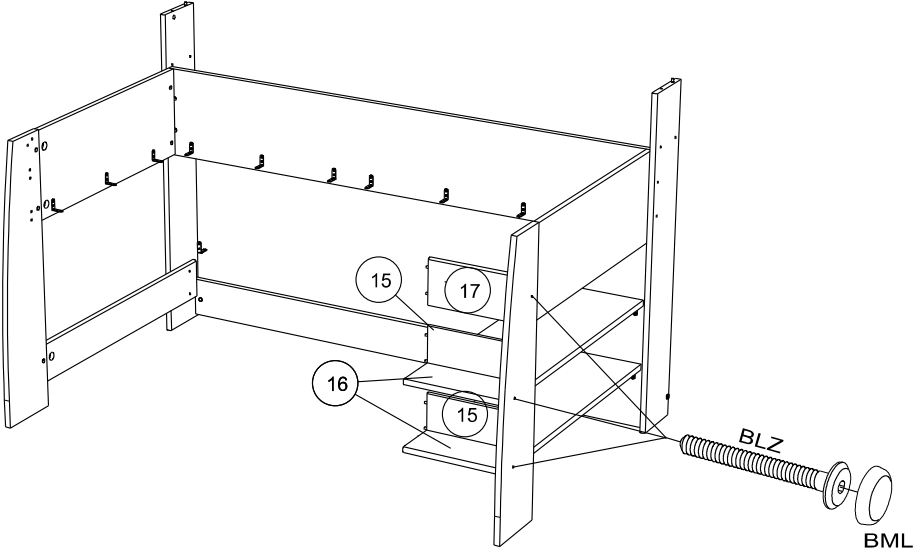

16

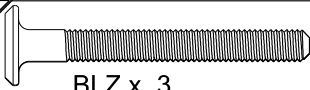

BLZ x 3



BML x 3



WJ x 4

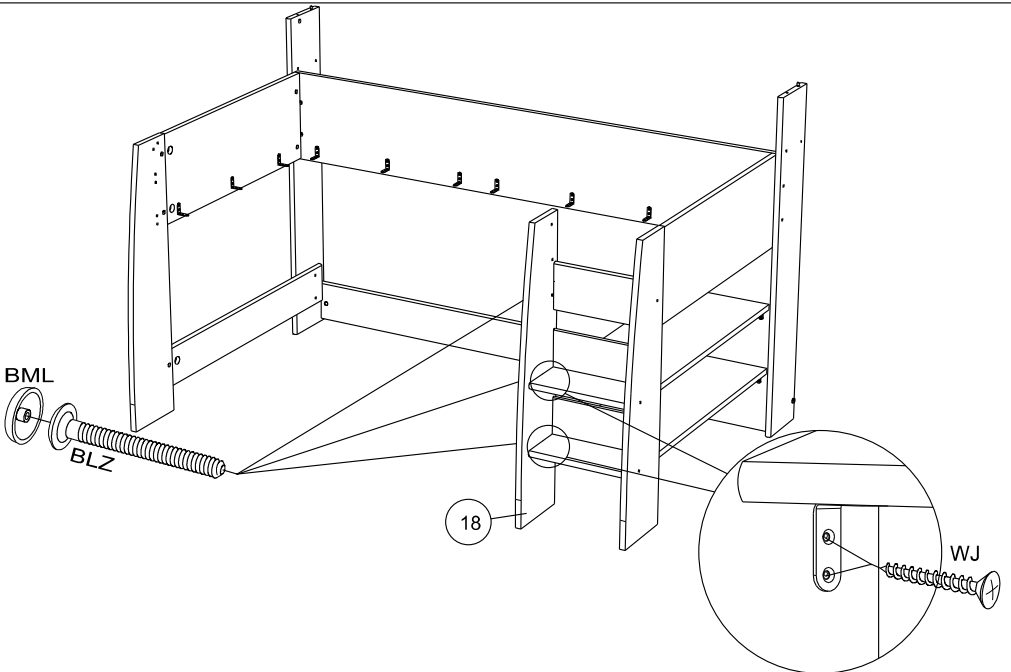

17



AP x 6



AHX x 6



LN x 6



WJ x 12



BSD x 2



ADM



AP

WJ x 2

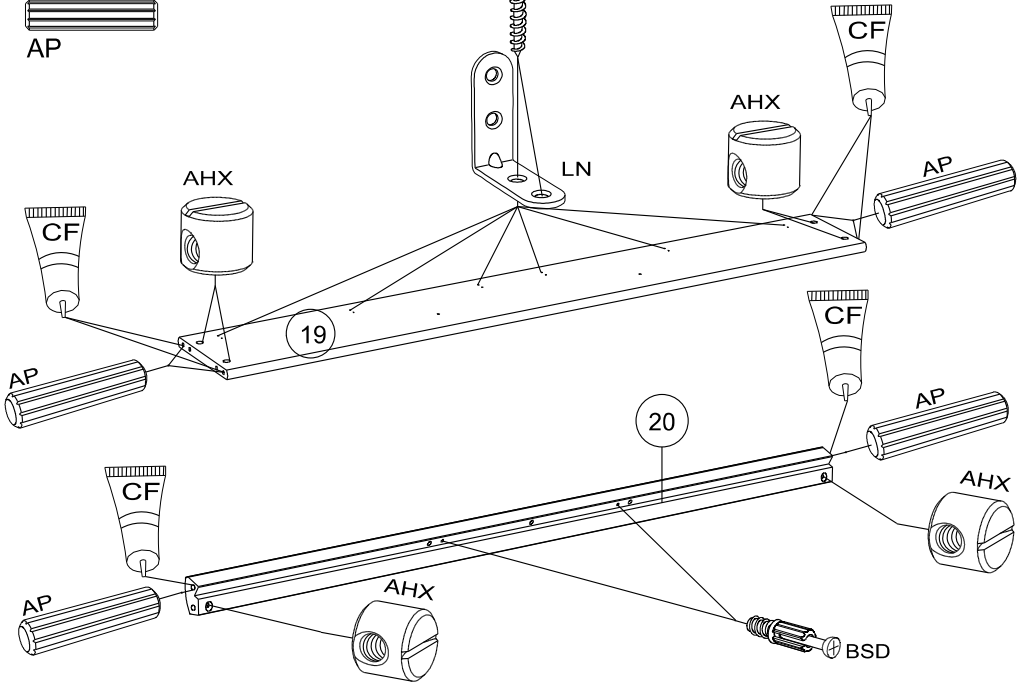

18



ADM x 3



ADM



AP

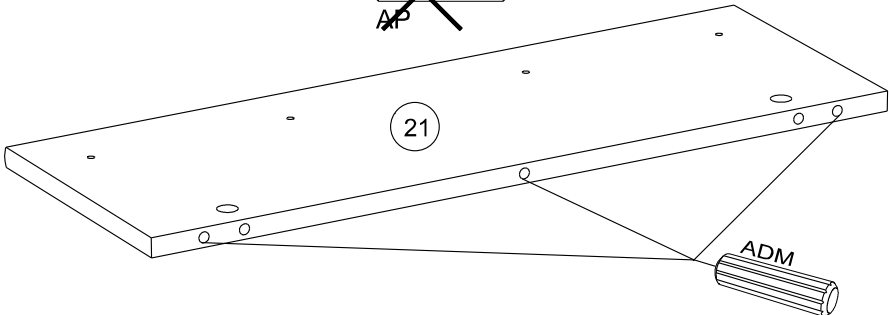

19

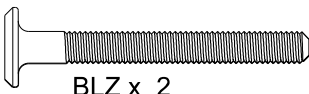

BLZ x 2



BML x 2

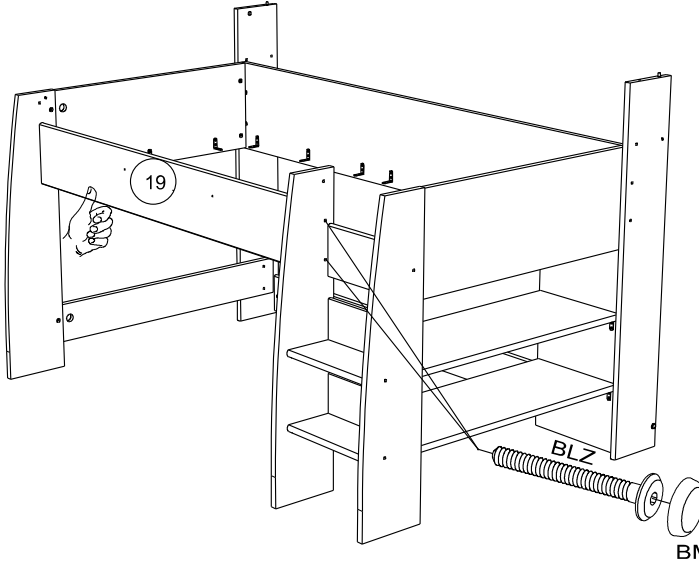

19

BLZ

BML

20

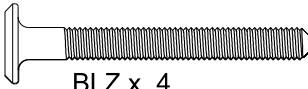

BLZ x 4



BML x 4



BAG x 4



VB x 4

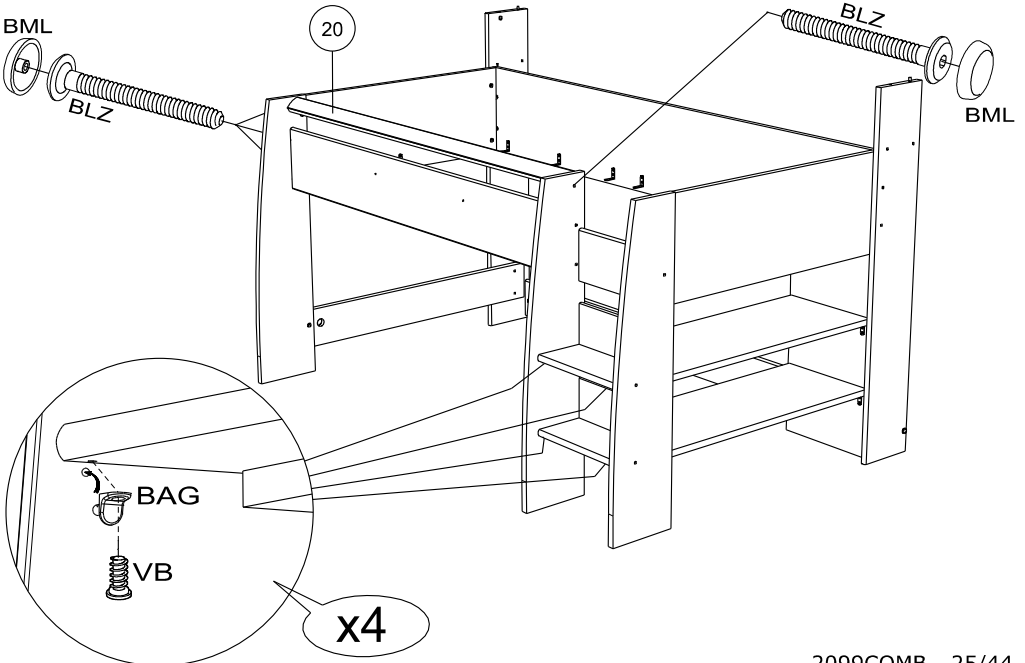

BML

20

BLZ

BLZ

BML

BAG

VB

x4

21



Ai x 2



WZ x 2



PP x 2

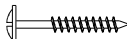

WH x 2

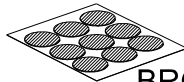

BRC x 1

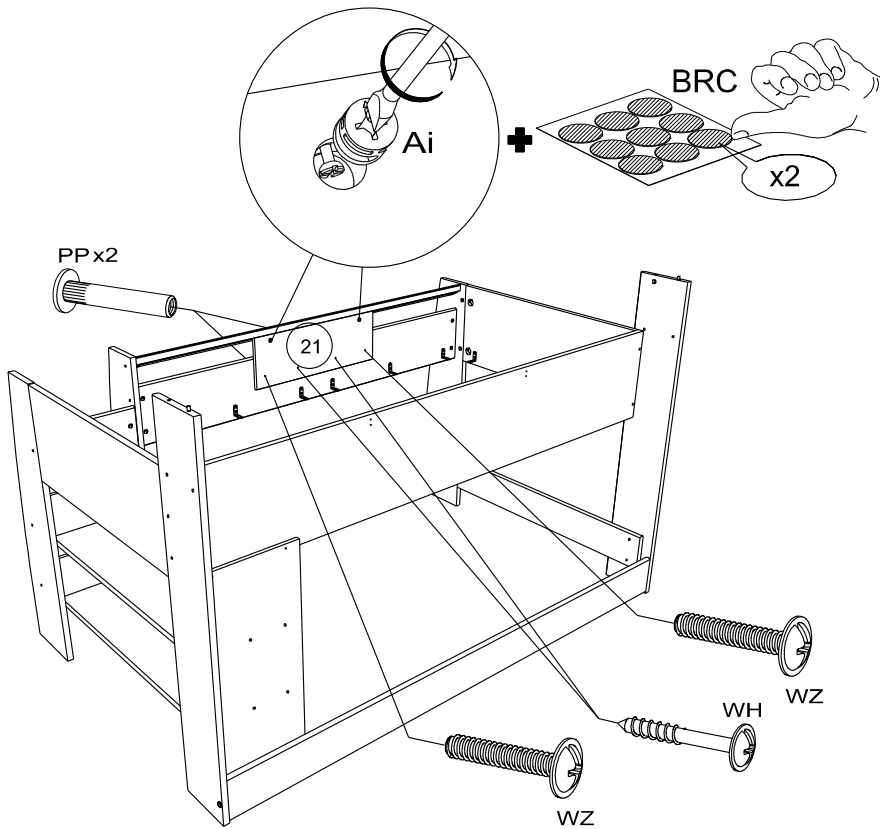

22



LN x 2



VG x 4

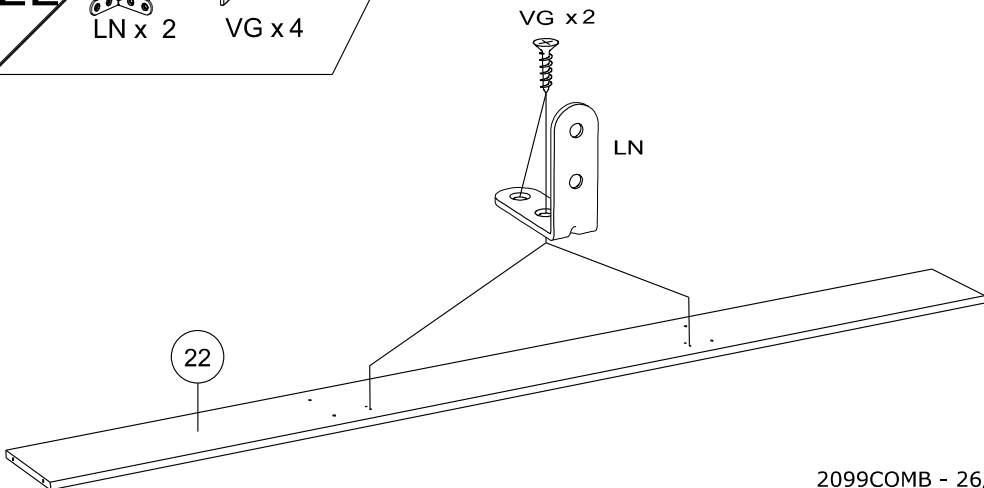

23

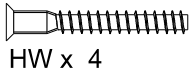

HW x 4



WA x 4

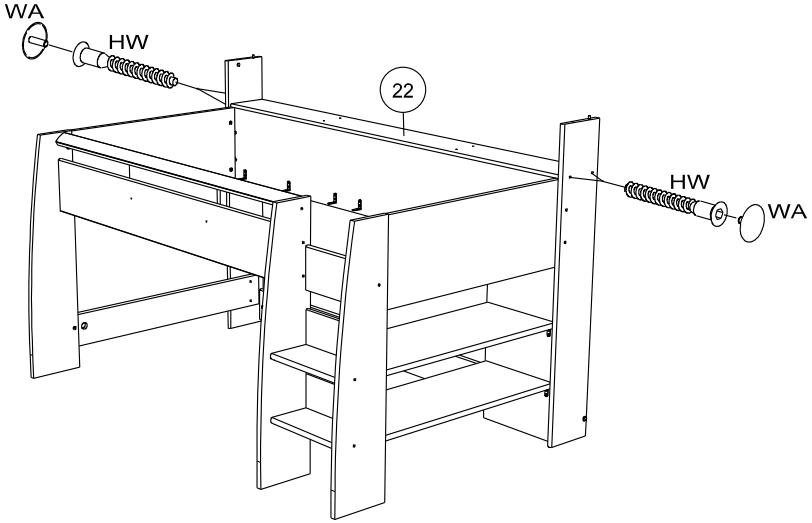

24

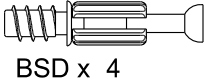

BSD x 4



ADM x 2

BSD

23

24

x2



ADM



25



Ai x 2

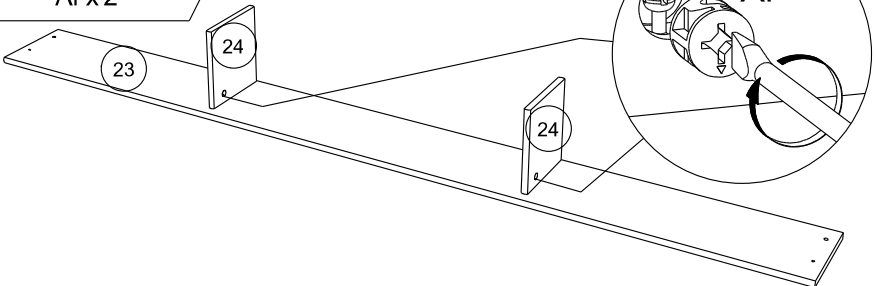

26



Ai x 2

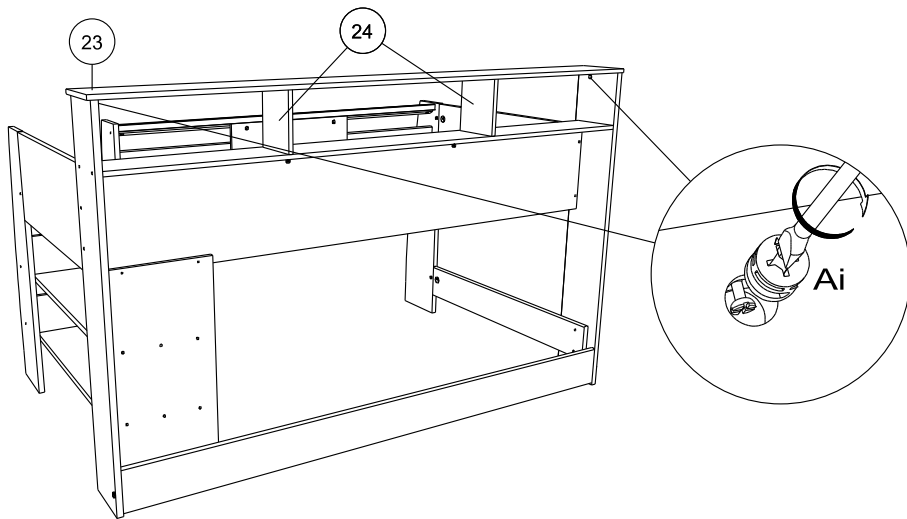

27



WJ x 4

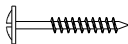

WH x 4

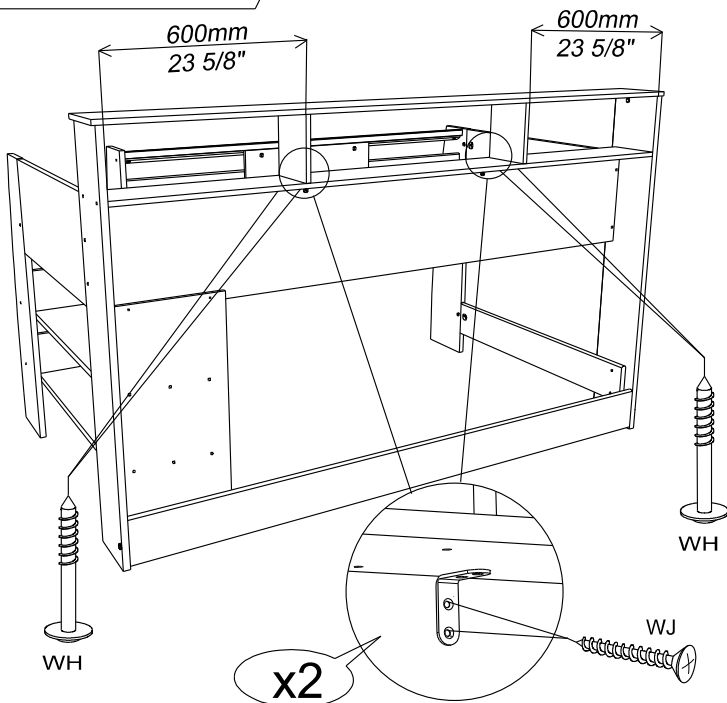

28

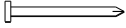

YB x 22

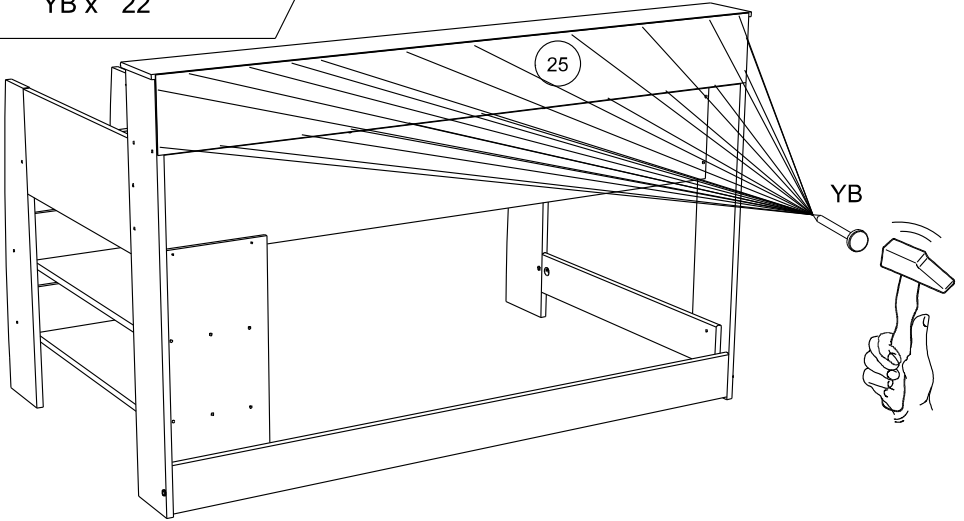

29

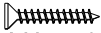

VJ x 4

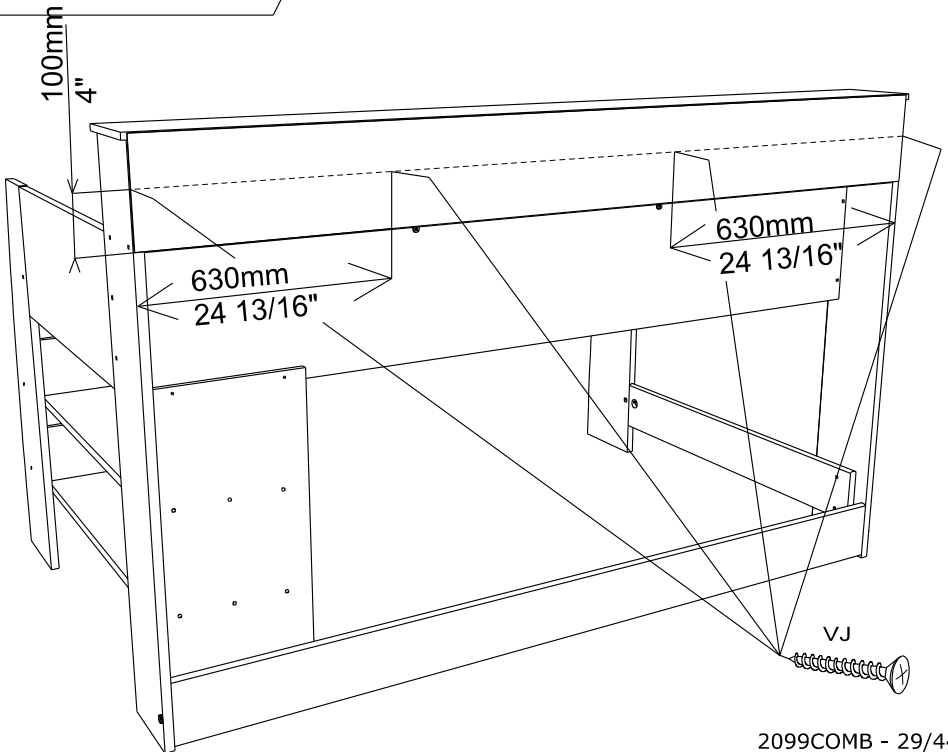

30

ADM x 4

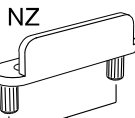

NZ x1

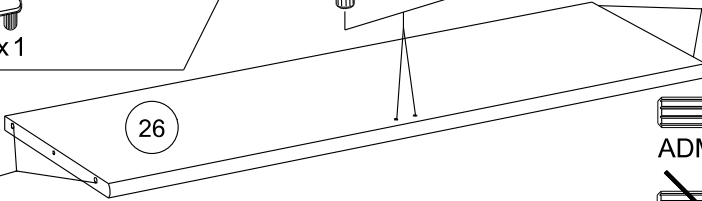

26

ADM



~~ADM~~
~~AP~~

31

AP x 4

AHX x 2



AHX



CF

AHX



CF



AP



AP

27

~~ADM~~



AP

32

ADM x 4

BXC x 1

XN x 1

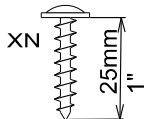

XN

25mm
1"

ADM



~~ADM~~
~~AP~~

BXC

28



ADM

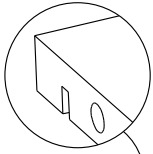

ADM



120mm
4 3/4"

500mm
19 11/16"

500mm
19 11/16"

33



BWU x4

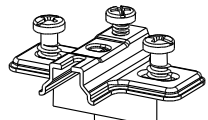

BWU

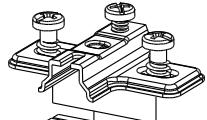

BWU

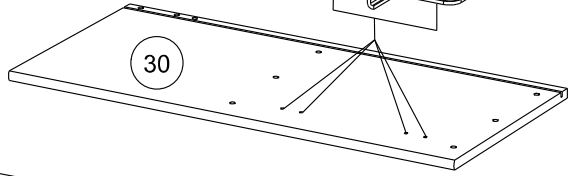

30

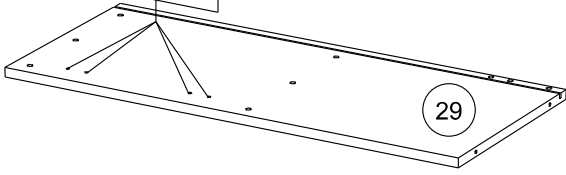

29

34

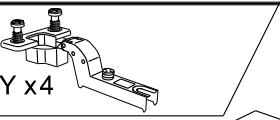

BWY x4

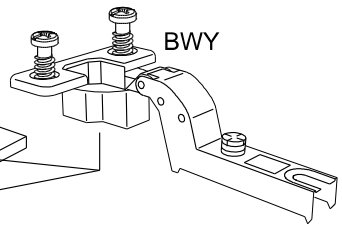

BWY

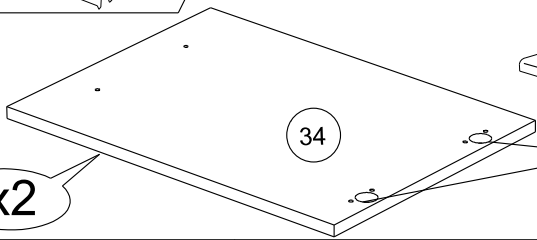

34

x2

35



HW x 4

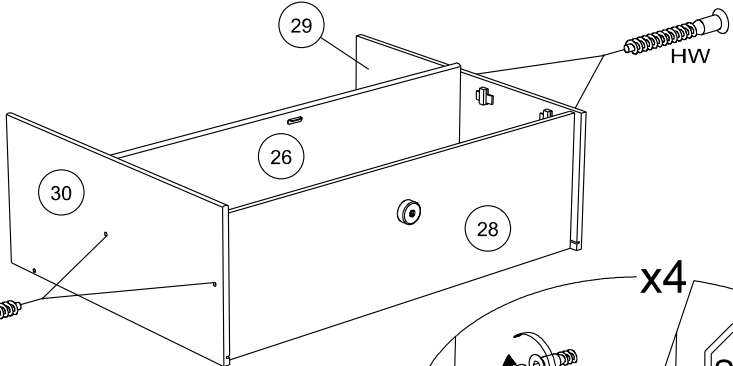

29

30

26

28

HW

HW

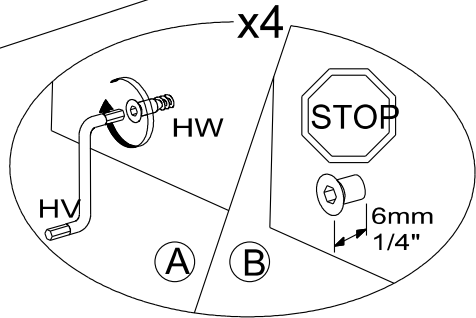

x4

A

B



6mm
1/4"

36

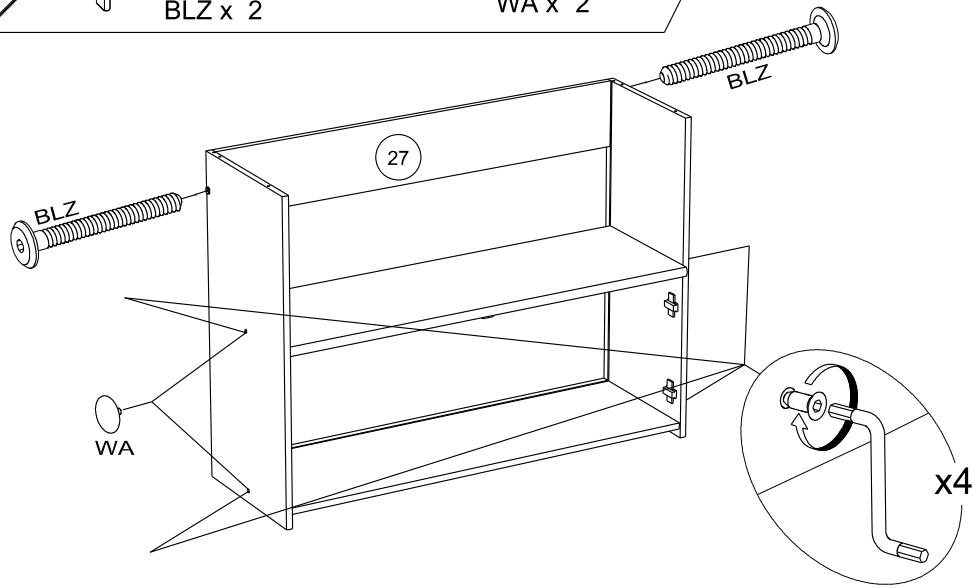
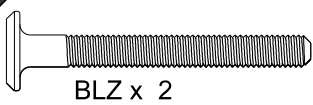

37

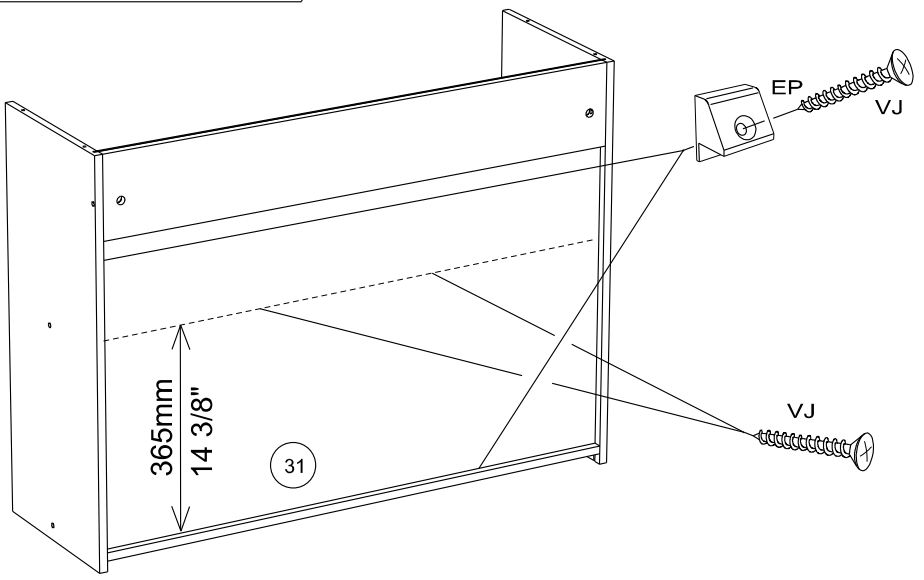

38

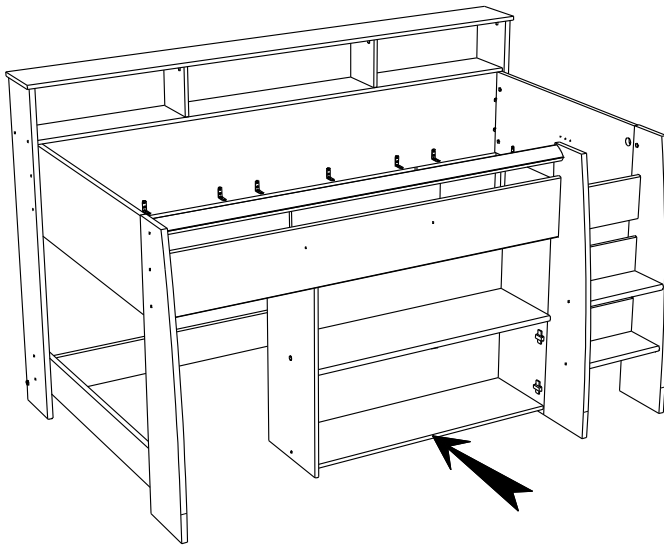

39

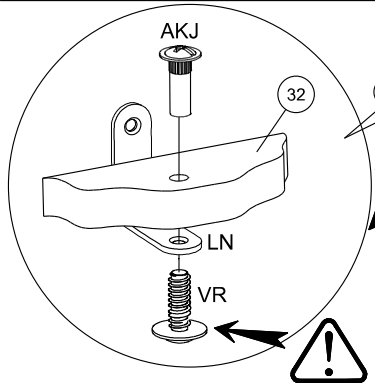
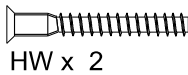
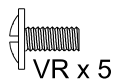
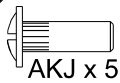

x5

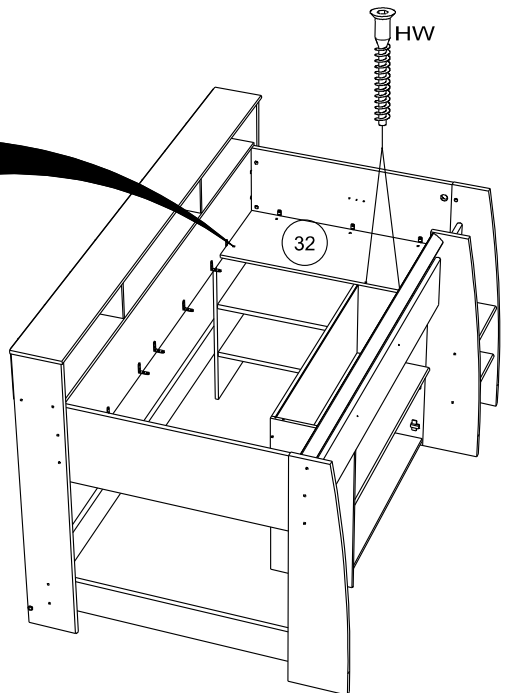
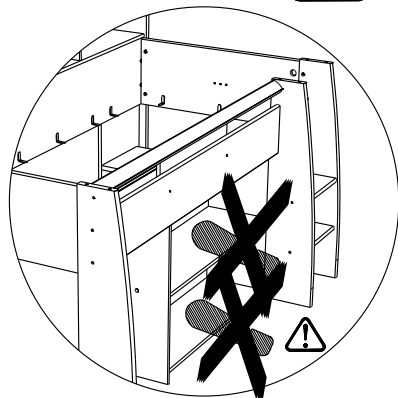

40

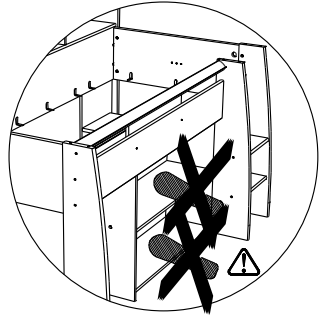
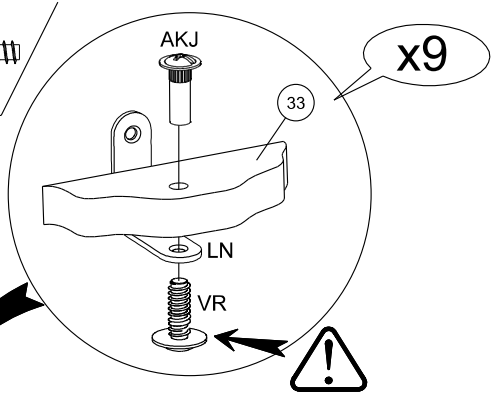
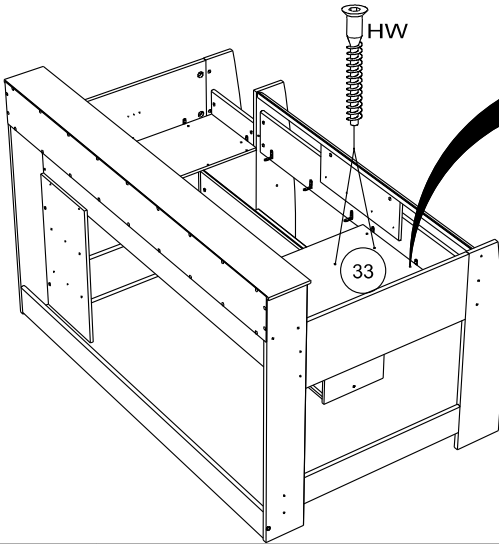
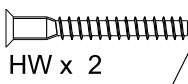
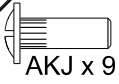

41

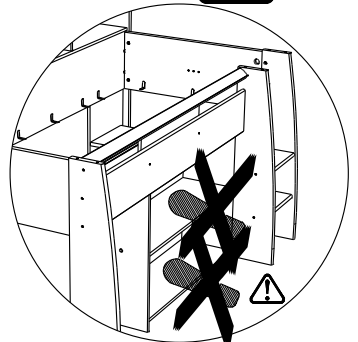
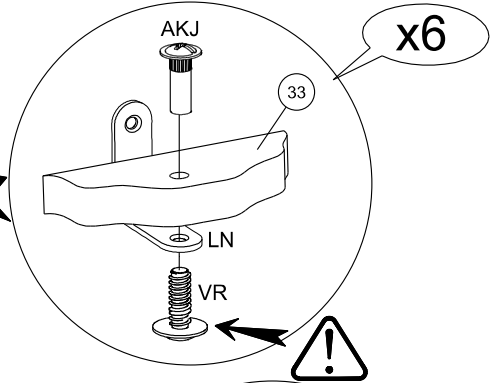
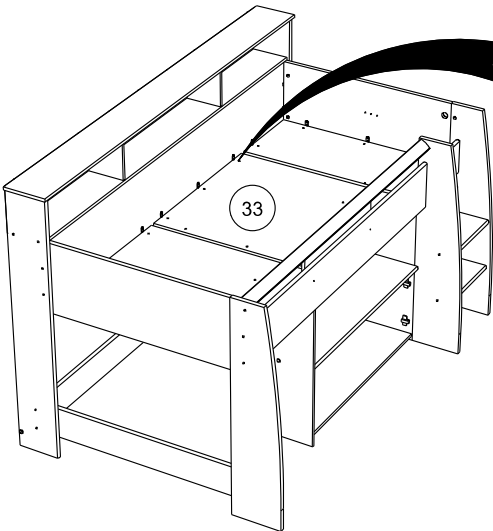
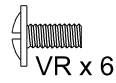
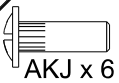

42

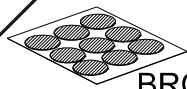

BRC x1



WZ x 4



POi x2

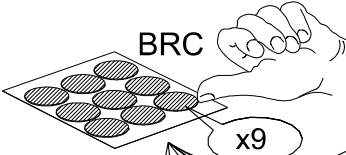

BRC

x9

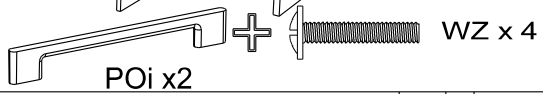
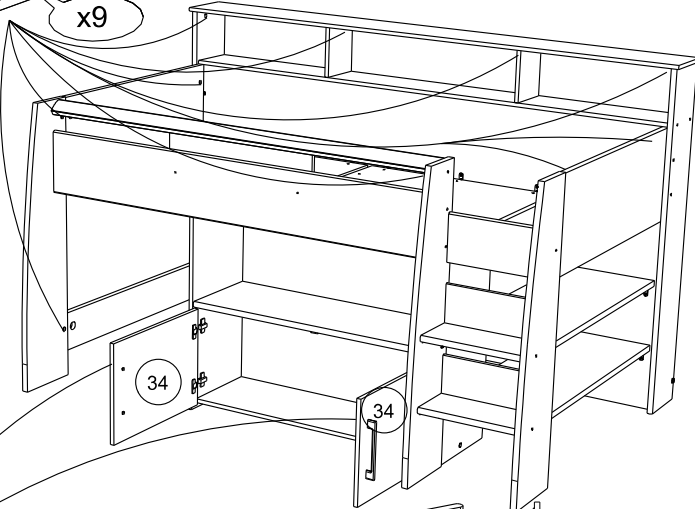

POi x2

WZ x 4

RCH-N

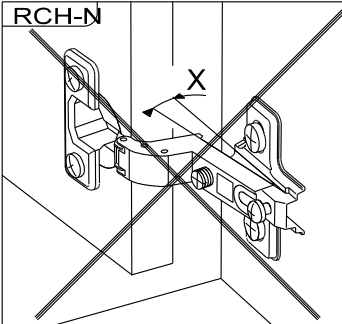

MONTAGE

- GB LEAFLET
- D AUFBAUANLEITUNG
- E MONTAJE
- P MONTAGEM
- I MONTAGGIO
- NL MONTAGE

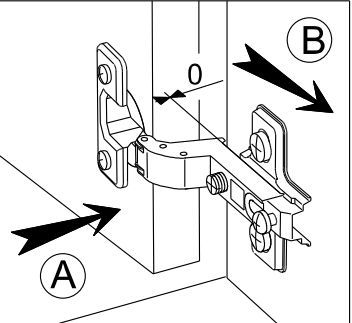

REGLAGE GB ADJUSTING E AJUSTER I AGGIUSTAMENTO
 D ANPASSUNG P REGULACAO NL AFSTELLING

A

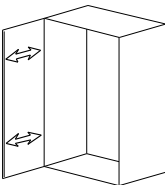

B

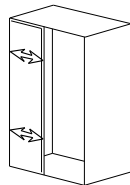

C

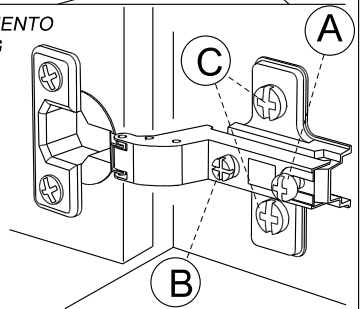
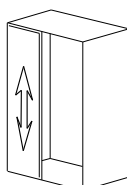

43

ADU x4

ADM x4

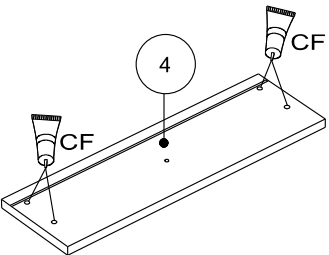
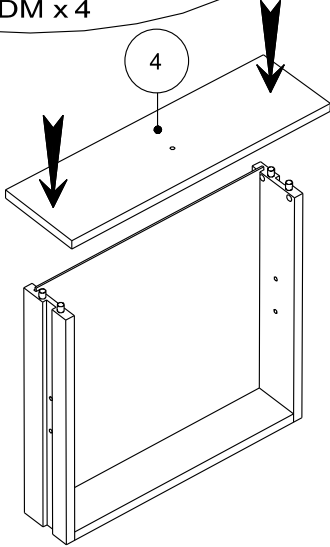
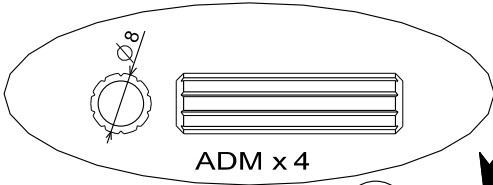
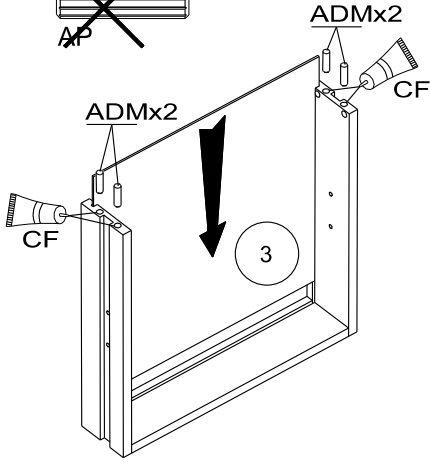
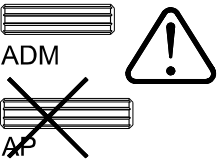
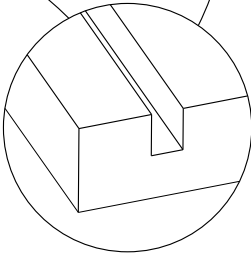
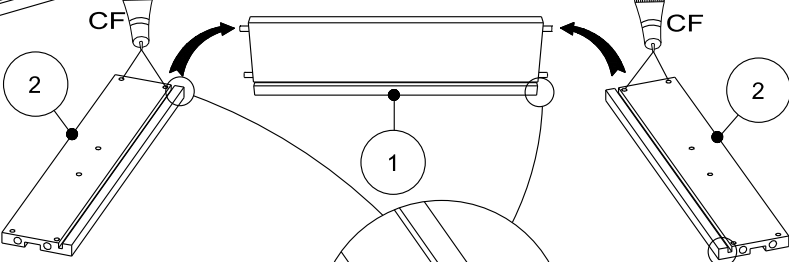
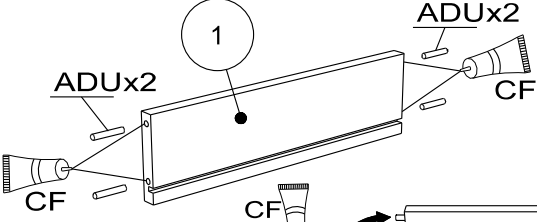
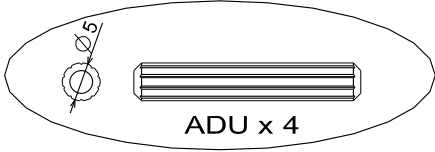

44

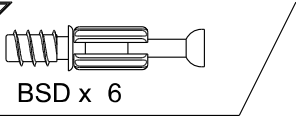

BSD x 6

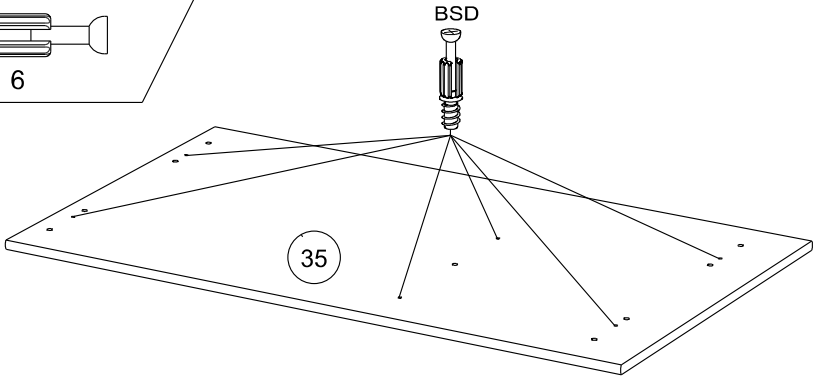

45



ADM x 5

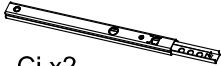

Ci x 2



ANK x 4



VG x 4

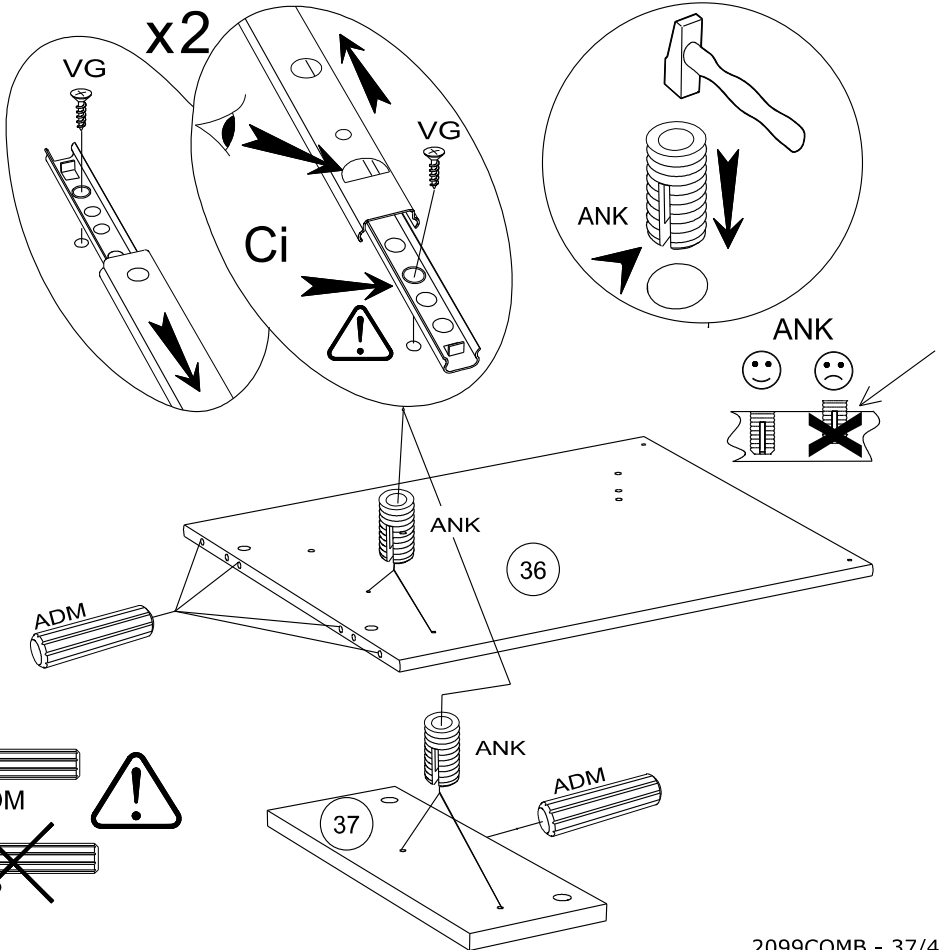

46



AP x 6



AHX x 4



~~ADM~~



AP

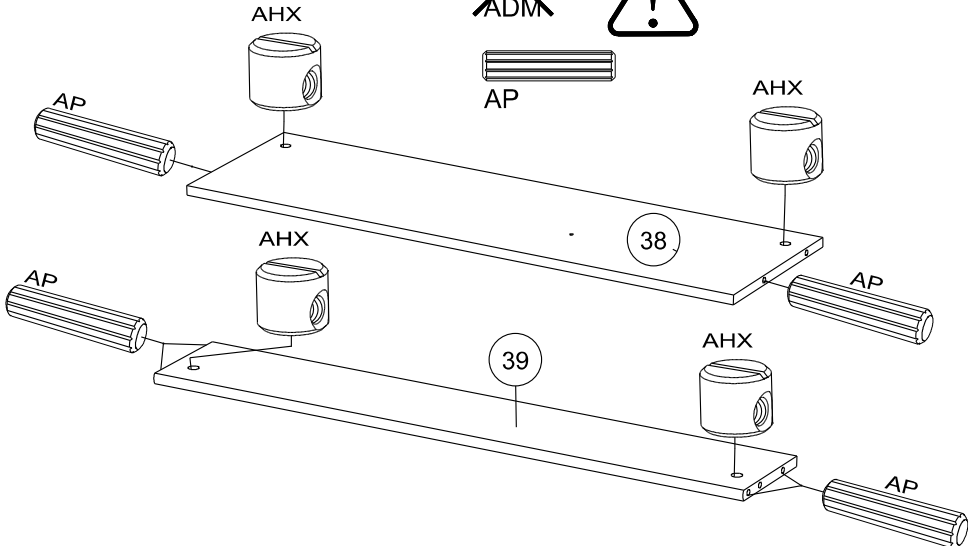

47



ADM x 4



ADM



~~AP~~

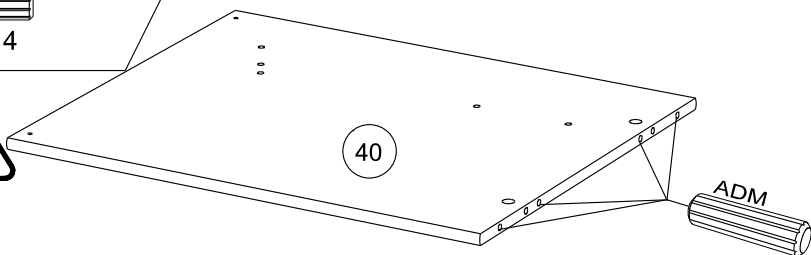

48

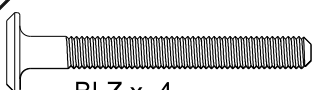

BLZ x 4



BML x 4

BML

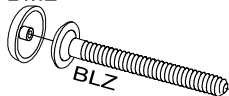

BLZ

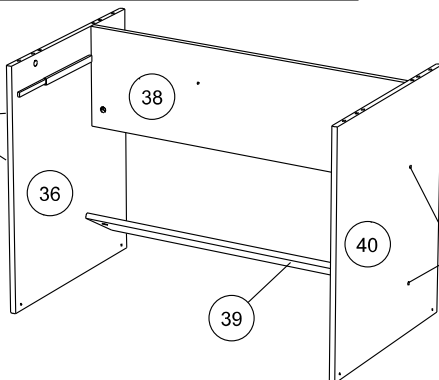

39

BLZ

BML

49



Ai x 4

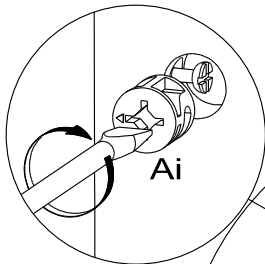

+

BRC

x3

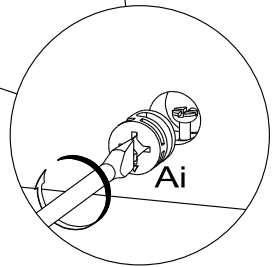
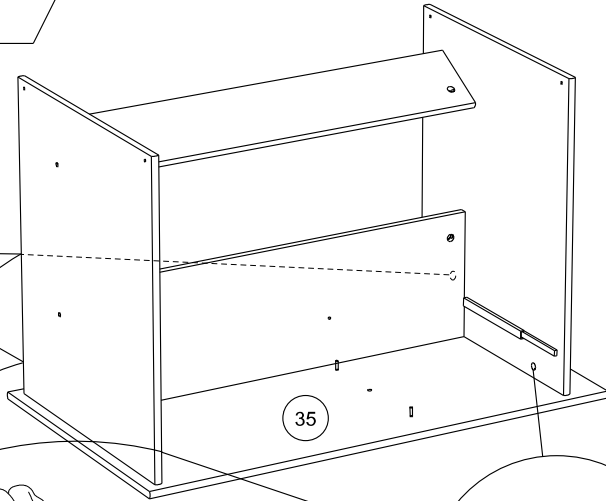

50



Ai x 2

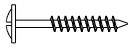

WH x 1

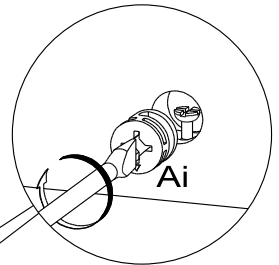
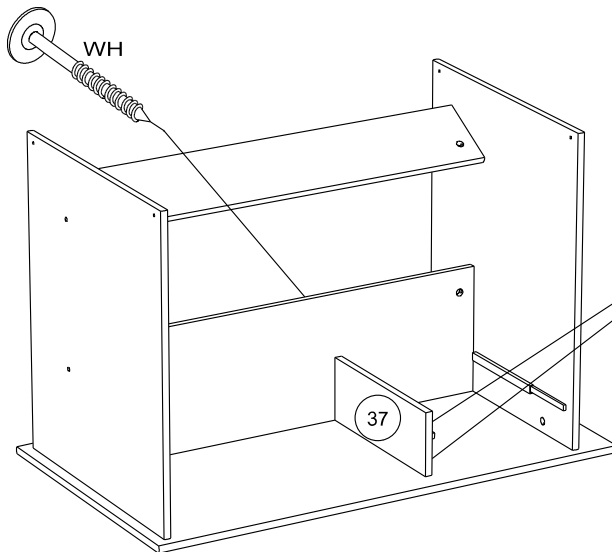

51



SD x 4



AKJ x 4



VR x 4

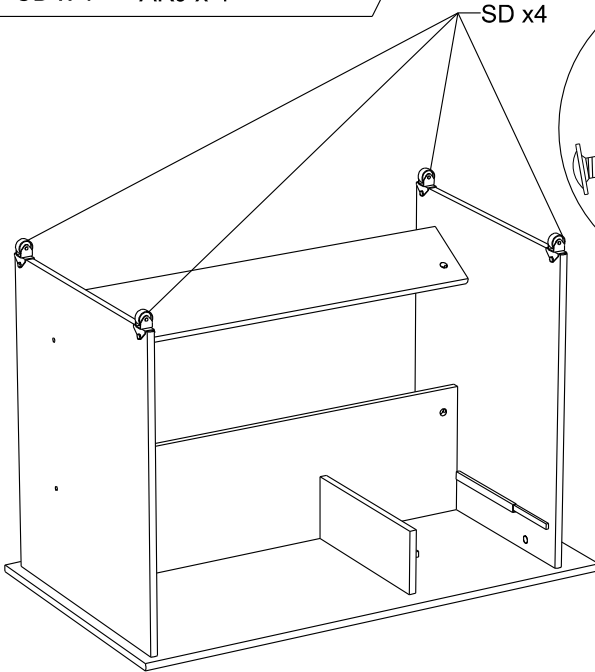

SD x 4

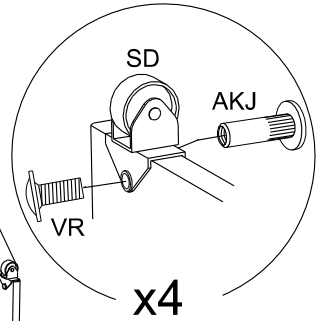

x4

52



VR x 2



WZ x 1



BOU x 1

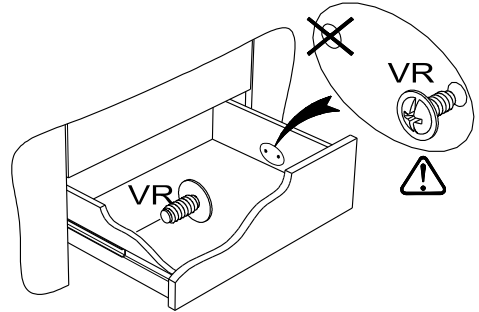
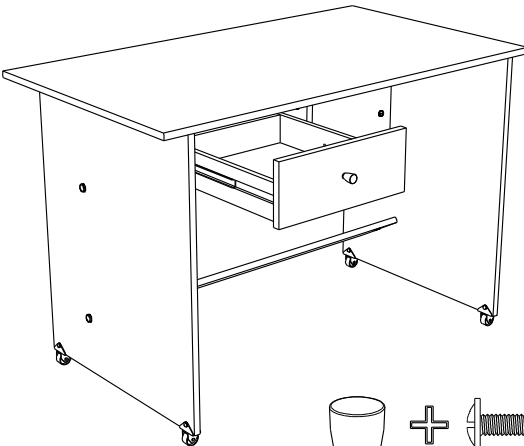

BOU x 1

WZ x 1

FR LA FACE SUPERIEURE DU MATELAS NE DOIT PAS SE TROUVER
AU DESSUS DE LA MARQUE FAITE SUR LE LIT

EN THE TOP SIDE OF THE MATTRESS SHOULD NOT BE HIGHER THAN THE LEVEL INDICATED ON THE BED.

DE DIE OBERSEITE DER MATRATZE DARF NICHT ÜBER DIE AM BETT VORHANDENE MARKIERUNG ÜBERSTEHEN

ES LA PARTE SUPERIOR DEL COLCHÓN NUNCA HA DE ENCONTARSE ENCIMA DE LA MARCA HECHA SOBRE LA CAMA

PT A FACE SUPERIOR DO COLCHÃO NÃO DEVE FICAR EM CIMA DA MARCA FEITA NA CAMA

IT IL LATO SUPERIORE DEL MATERASSO NON DEVE TROVARSI AL DI SOPRA DEL MARCHIO POSTO SUL LETTO

NL DE BOVENZIJDE VAN DE MATRAS MAG NIET BOVEN DE MARKERING OP HET BED UITSTEKEN

CZ HORNÍ STRANA MATRACE NESMÍ VYČNÍVAT NAD ZNAČKU NA POSTELI

HU A MATRAC FELSŐ OLDALA NEM LEHET MAGASABBAN MINT AZ ÁGYON TALÁLHATÓ JELZÉS

PL GÓRNA POWIERZCHNIA MATERACA NIE MOŻE ZNAJDOWAĆ SIĘ POWYŻEJ OZNACZENIA NA ŁÓŻKU

RO FAȚA SUPERIOARĂ A SALTELEI NU TREBUIE SĂ DEPĂȘEASCĂ MARCAJUL DE PE PAT

RU НАРУЖНАЯ ЧАСТЬ МАТРАСА НЕ ДОЛЖНА НАХОДИТЬСЯ ВЫШЕ СПЕЦИАЛЬНОЙ ОТМЕТКИ НА КРОВАТИ

SK VRCHNÁ ČASŤ MATRACA SA NESMIE NACHÁDZAŤ NAD ZNAČNOU VYZNAČENOU NA POSTELI

TR SOMYANIN ÜST YÜZÜ, YATAK ÜZERİNDEKİ İŞARETİN ÜSTÜNDE YER ALMAMALIDIR

الجانب العلوي للمرتبة لا يجب أن يتجاوز العلامة الموجودة على السرير

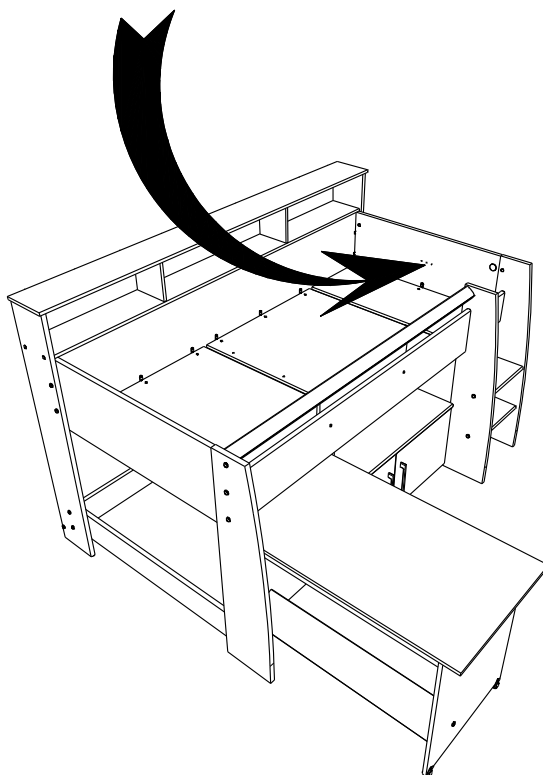

- FR** Pour votre sécurité : Fixation du meuble au mur
Attention, la fixation doit être réalisée par une personne compétente car cela nécessite des chevilles adaptées à la nature de votre mur.
- EN** For your safety: the unit should be secured to the wall.
NB this should be carried out by a competent person as you must use the right rawlplug for your type of wall.
- DE** Zu Ihrer Sicherheit: Befestigen Sie das Hochbett an der Wand.
Achtung: Diese Befestigung ist durch eine fachlich kompetente Person vorzunehmen. Hierfür sind für die Bauweise Ihrer Wand geeignete Dübel einzusetzen.
- ES** Por su seguridad: Fijar el mueble a la pared.
Advertencia: la fijación la ha de llevar a cabo por personal adecuado, ya que requiere el uso de tacos que se adapten al tipo de pared.
- PT** Para sua segurança: fixação do móvel ao muro
Atenção: a fixação deverá ser efetuada por pessoa habilitada, visto que são necessárias cavilhas adaptadas ao tipo de parede.
- IT** Avvertenza di sicurezza: il fissaggio del mobile a parete deve essere realizzato da una persona competente, in quanto l'operazione richiede l'impiego di tasselli adatti alla natura del muro.
- NL** Voor uw veiligheid: bevestiging van het meubel aan de muur.
Opgelet de bevestiging moet worden uitgevoerd door een bekwaam persoon daar dit voor uw type muur geschikte pluggen vereist.
- CZ** Z bezpečnostních důvodů: upevněte nábytek do zdi
Pozor, upevnění je třeba svěřit kompetentní osobě, neboť vyžaduje hmoždinky vhodné pro vaši zed'.
- HU** Az Ön biztonsága érdekében : a bútor falra rögzítése
Figyelmeztetés : a rögzítés csak megfelelő szakképesítéssel rendelkező személy által végezhető el, mert a rögzítéshez a falnak megfelelő csavarokra van szükség.
- PL** Dla bezpieczeństwa: mocowanie mebla do ściany
Uwaga, mocowanie musi zostać wykonane przez osobę kompetentną, ponieważ wymaga to zastosowania kółków dostosowanych do rodzaju ściany.
- RO** Pentru securitatea dumneavoastră: fixarea mobilierului de perete
Atenție, fixarea trebuie să fie realizată de o persoană calificată, deoarece sunt necesare dispozitive de fixare adaptate caracteristicilor peretelui dumneavoastră
- RU** Для вашей безопасности: Крепление мебели к стене
Внимание! Крепление должно производиться опытным специалистом, т.к. для такой установки потребуются штифты, соответствующие типу вашей стены.
- SK** Z bezpečnostných dôvodov: nábytok upevnite k stene.
Dbajte na to, aby upevnenie vykonala kompetentná osoba, pretože pri upevňovaní sa vyžadujú kolíky vhodné do materiálu, z ktorého je stena vyrobená.
- TR** Güvenliğiniz için: Mobilyanın duvara sabitlenmesi
Dikkat, sabitleme işlemi uzman biri tarafından yapılmalıdır çünkü bu işlem için duvarınızın malzemesine uygun dübellerin kullanılması gerekmektedir
- GR** Για την ασφάλειά σας : στερέωση των επίπλων στον τοίχο.
Προσοχή, η στερέωση πρέπει να γίνεται από ικανό άτομο, καθώς απαιτούνται σφήνες προσαρμοσμένες στη φύση του τοίχου σας.

اللغة العربية

سلامتک الشخصیة: تثبیت قطعة الأثاث على الحائط
تذیر، يجب أن يقوم شخص متخصص بعملية التثبيت على الحائط إذ أنها تتطلب اسفینا
معینا يتوافق مع طبيعة الحائط نفسه.

55



BLL x2



VG x2

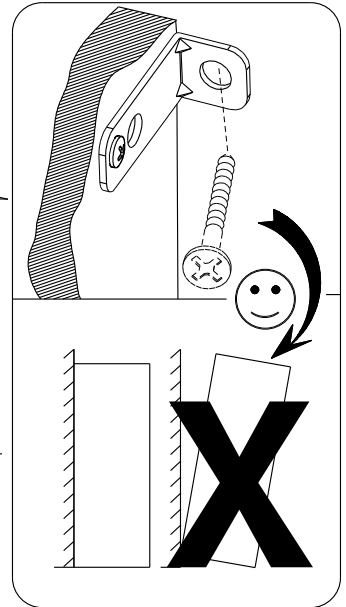
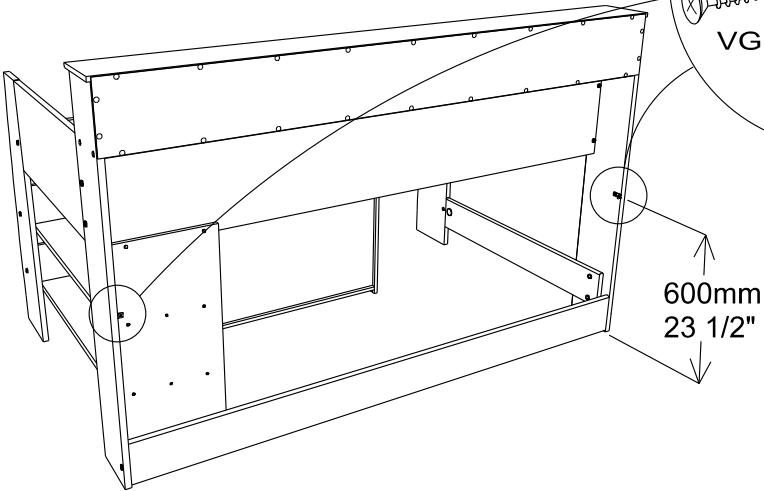

- FR** Attention pour votre sécurité, ne pas dépasser les charges maxi
EN Caution! For your safety, do not exceed the maximum load
DE Achtung: Zu Ihrer Sicherheit ist die zulässige Höchstlast nicht zu überschreiten
ES Advertencia: Por su seguridad, no superar las cargas maxi
PT Atenção, para sua segurança, não ultrapasse as cargas máximas
IT Attenzione, per ragioni di sicurezza, non superare i valori massimi di carico indicati
NL Opgelet, voor uw veiligheid het maximum gewicht niet overschrijden
CZ Pozor, z bezpečnostních důvodů nepřekračujte maximální zátěž
HU Az Ön biztonsága érdekében ne haladja meg a maximális terhelést
PL Uwaga! Ze względów bezpieczeństwa nie przekraczać obciążeń maksymalnych
RO Atenție, pentru securitatea dumneavoastră, nu depășiți sarcina maximă
RU Внимание! Для вашей безопасности, не превышайте максимально допустимый вес
SK Upozornenie: Z bezpečnostných dôvodov neprekračujte maximálne záťaž
TR Dikkat, güvenliğinizi için maksimum yük seviyelerini aşmayın

اللغة العربية

حرصاً على سلامتكم، يرجى عدم تجاوز أقصى حمولة

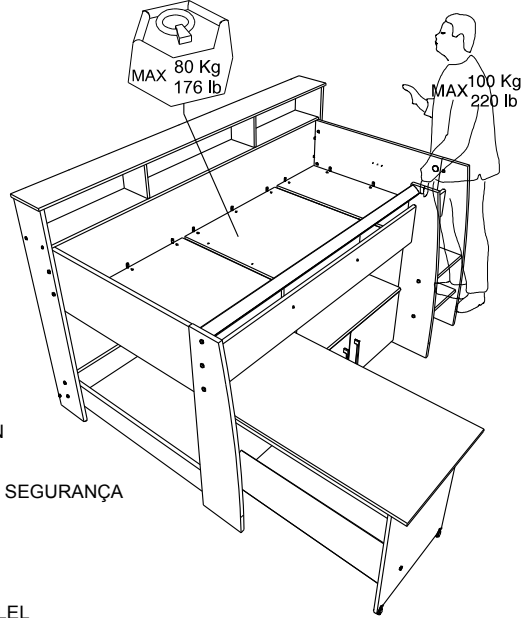

- FR** CONFORME AUX EXIGENCES DE SECURITE
EN MEETS SAFETY STANDARDS
DE ERFÜLLT DIE SICHERHEITANFORDERUNGEN
ES CONFORME A LAS NORMAS DE SEGURIDAD
PT EM CONFORMIDADE COM OS REQUISITOS DE SEGURANÇA
IT CONFORME AI REQUISITI DI SICUREZZA
NL VOLDOET AAN DE VEILIGHEIDSNORMEN
CZ VYHOVUJE BEZPEČNOSTNÍM POŽADAVKŮM
HU A BIZTONSÁGI KÖVETELMÉNYEKNEK MEGFELEL
PL WYRÓB SPEŁNIA WYMOGI BEZPIECZEŃSTWA
RO CONFORM CU CERINȚELE DE SECURITATE
RU СООТВЕТСТВУЕТ ТРЕБОВАНИЯМ БЕЗОПАСНОСТИ
SK VYHOVUJE BEZPEČNOSTNÝM POŽIADAVKÁM
TR GÜVENLİK KURALLARINA UYGUNDUR

يتوافق مع جميع اشتراطات السلامة

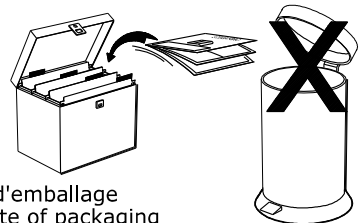

Faites un geste pour l'environnement en triant vos déchets d'emballage
 Make a gesture for the environment by sorting out your waste of packaging
 Machen Sie eine Bewegung für die Umwelt, ihre Verpackungsabfälle sortierend
 Haga un gesto para el medio ambiente escogiendo sus residuos de embalaje