

# Johnson bed

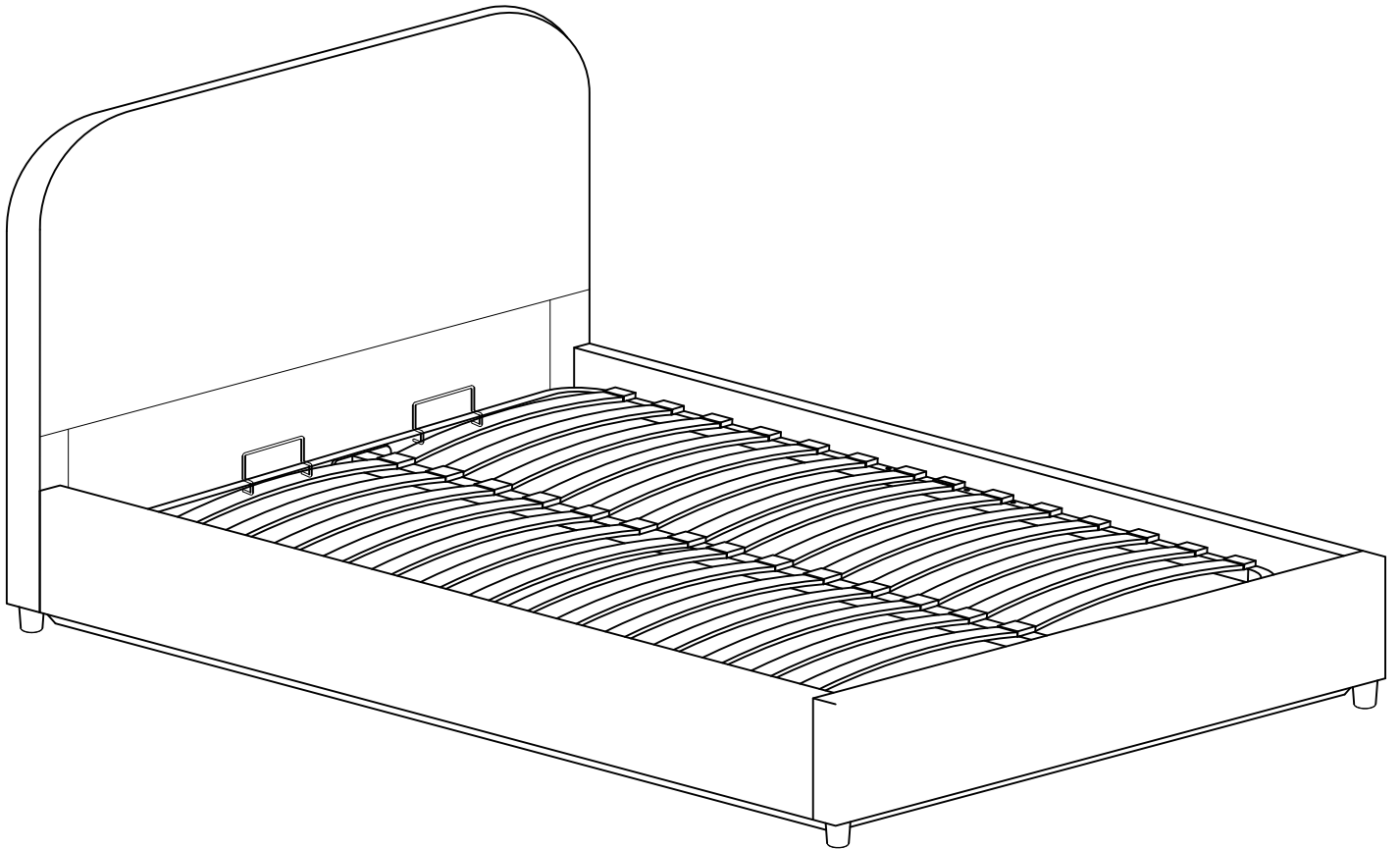

1 hour approx  
assembly time



Two person  
assembly

**Dreams**

# Thank you

Hello, thanks for choosing to purchase your bed from Dreams - you're now on your way to your best ever night's sleep. Before you begin building your bed, please take a moment to read through the instructions and make sure that you've got all the relevant parts listed on the following pages.



## Assembly tips

Before you begin, it's best to identify all parts and fittings to build your bed. We advise laying these out on the floor to check you have everything, and familiarising yourself before building.



## Top tip

We recommend that you build your new bed in the room you'd like it to be located - this will help prevent any risk of damage to your newly built bed whilst moving it.



## Safety and care

It's really important to ensure children and animals are kept away from the assembly area, as there are small components used in this bed which could present a choking hazard. All plastic and wrapping materials should also be kept away from children and animals to prevent any risk of suffocation. To keep your little ones busy, there is a colouring page inside the back cover.



## Help and support

At Dreams, it's our mission to give the whole nation a great night's sleep - this means that the quality of our products is of utmost importance to us. If there are any issues with your product or any missing parts, please visit our website at [www.dreams.co.uk/help](http://www.dreams.co.uk/help)



## Recycling

Please ensure that packaging is disposed of in a safe and environmentally friendly way, and recycle where possible. Our assembly instructions are printed on recycled paper. Please keep your assembly instructions safe to refer back to in the future.

# IMPORTANT OTTOMAN SAFETY WARNINGS

- IMPORTANT – READ CAREFULLY – RETAIN FOR FUTURE REFERENCE
- You must ensure that the mattress is on the bed frame before operating the lift mechanism – Failure to do so could result in injury.
- Keep hands clear of the mechanism when opening or closing the ottoman.
- Beware of entrapment – Never reach in through the mechanism to access the storage area.
- Always ensure that the ottoman is FULLY opened before accessing the storage area.
- Do not reach into the storage area through the hinge mechanism.
- Do not exceed the maximum weight as specified in the table below:

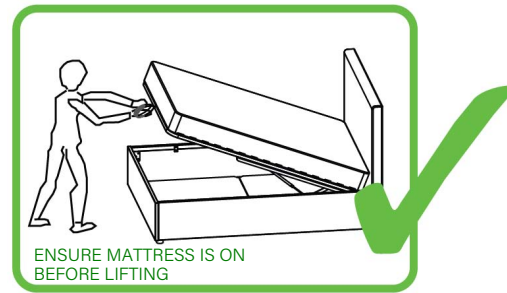

Bed	Bed Size	Min Weight (kg)	Max Weight (kg)
Johnson bed	Double	20	40
	King	20	40

- Use caution when operating, always use the handle when lifting
- Note: This bed uses a pressurised mechanism.
- To be operated by adults only
- Please ensure that children and pets are kept away from the bed when operating the lift mechanism.
- Keep children and pets away from the storage area.
- No children or animals are left unattended when the frame is in the ' up' position.
- Do not overload the internal storage base.
- Do not stand inside the internal storage area of the bed
- Before removing the mattress secure the frame to ensure it does not open unexpectedly.
- Do not attempt to lie on the mattress when the ottoman is in the raised position.
- When lifting the ottoman remove all bedding except the fitted sheet.
- Depending on the weight of the mattress, the rising speed will vary so be careful until you get used to the speed.
- NOTE: When fully assembled and the mattress is in position, please raise and lower the ottoman 4 / 5 times to ensure the gas pistons are fully lubricated.

# Parts

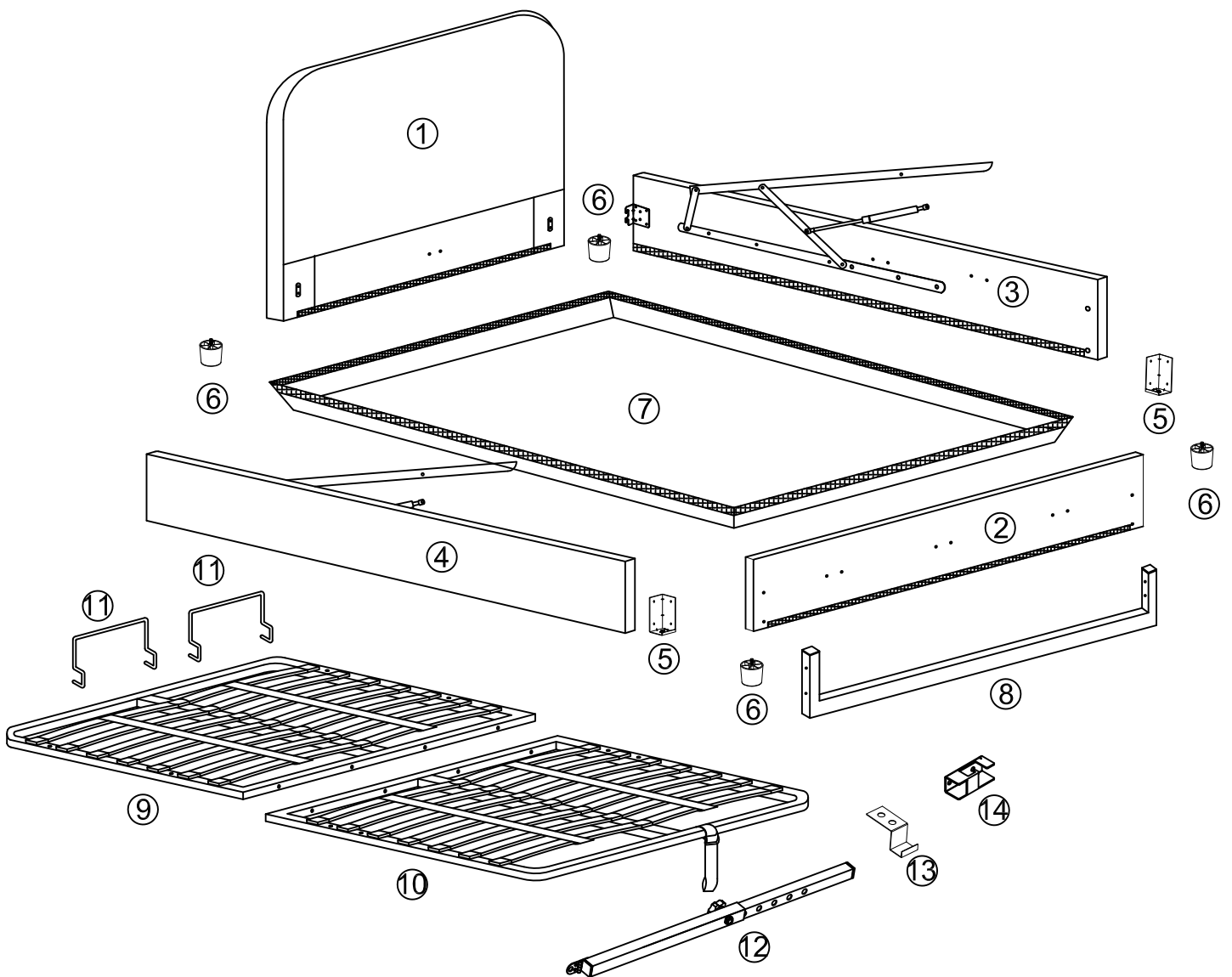





## Parts list

- |                        |                              |
|------------------------|------------------------------|
| 1. Headboard x 1       | 8. Centre Supporter x 1      |
| 2. Footboard x 1       | 9 . Slat Frame x 1           |
| 3. Right Side Rail x 1 | 10. Slat Frame x 1           |
| 4. Left Side Rail x 1  | 11. Mattress holder x 2      |
| 5. Brackets x 2        | 12 . Ottoman support bar x 1 |
| 6. leg x 4             | 13. Hanger x 1               |
| 7. Baseboard x 1       | 14. Brackets x 1             |

# Fittings

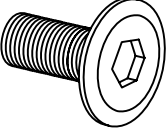
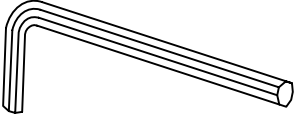
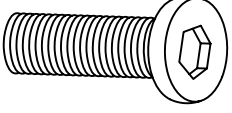
Please check you have all the parts listed below with your product:

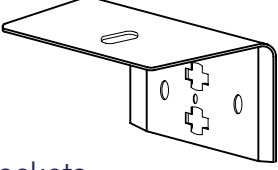
## Bag 1

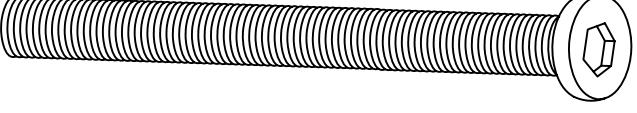
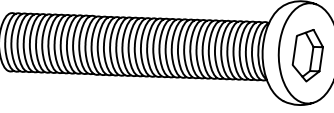
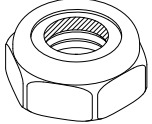
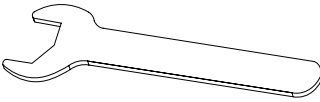
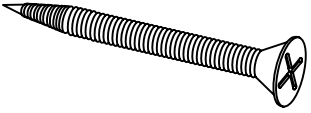
<p>A x 4 pcs</p>  <p>Bolts (M8 x 18mm)</p>	<p>B x 1 pc</p>  <p>Allen Key (for M8 bolt)</p>	<p>C x 20 pcs</p>  <p>Bolts (M8 x 25mm)</p>	<p>D x 32 pcs</p>  <p>Washers (M8 x 22mm)</p>
<p>E x 6 pcs</p>  <p>Brackets</p>	<p>F x 8 pcs</p>  <p>Felt Pads</p>	<p>G x 4 pcs</p>  <p>Bolts (M8 x 80mm)</p>	
<p>H x 8 pcs</p>  <p>Bolts (M8 x 45mm)</p>	<p>I x 12 pcs</p>  <p>Nuts (M8)</p>	<p>J x 1 pc</p>  <p>Spanner (for M8 nut)</p>	<p>K x 4 pcs</p>  <p>Screws (M5 x 40mm)</p>

## Bag 2 Hardware for ottoman support bar

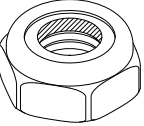
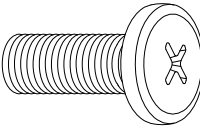
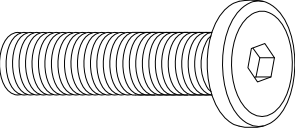
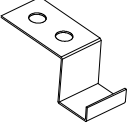
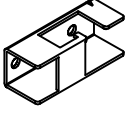
<p>I x 1 pc</p>  <p>Nuts (M8)</p>	<p>L x 4 pcs</p>  <p>Bolts (M8 x 20mm)</p>	<p>M x 1 pc</p>  <p>Bolts (M8 x 40mm)</p>	 <p>13. Hanger x 1</p>	 <p>14. Brackets x 1</p>
--	---	---	---	---

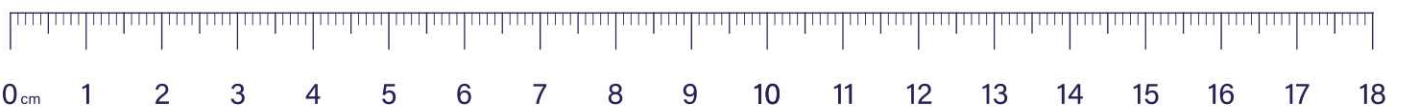

# Tools required

Please check you have all these below



Tape measure



Cross head screwdriver

# Step 1

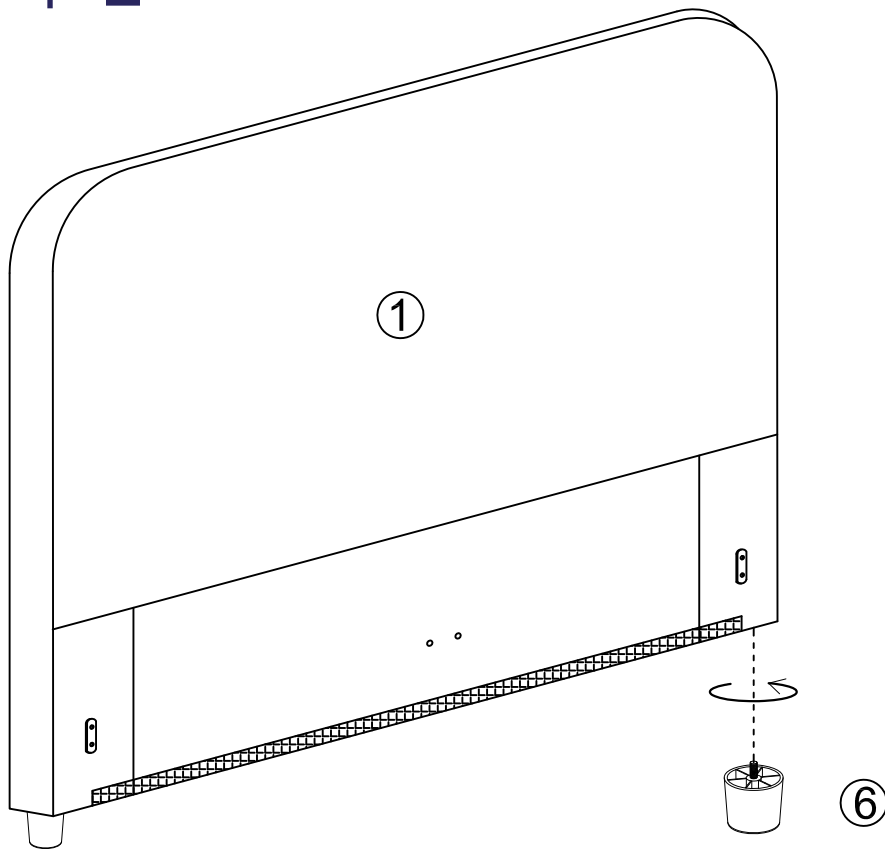

Attach 2 x legs (6) to the bottom of headboard (1).

---

# Step 2

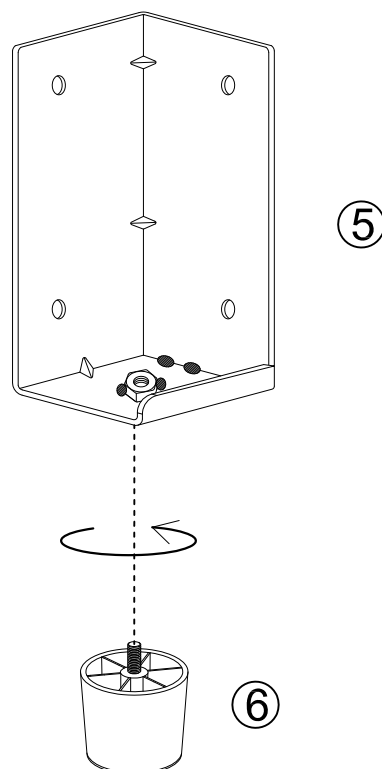

Attach 2 x legs (6) to the bottom of bracket (5).

# Step 3

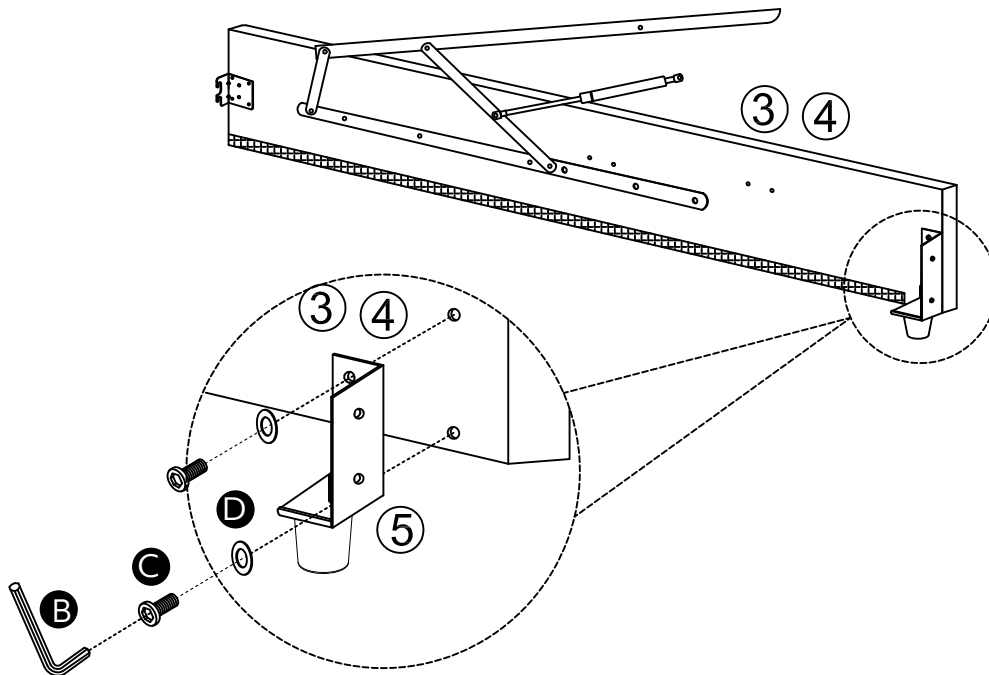
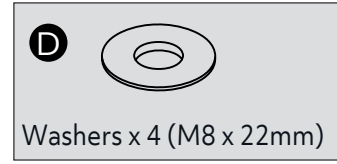
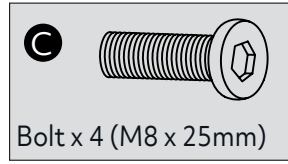
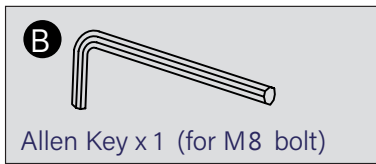

Attach brackets (5) to side rail (3 and 4) with 4 X bolts 25mm (C) and 4 X washers (D) by Allen key (B) as shown.

# Step 4

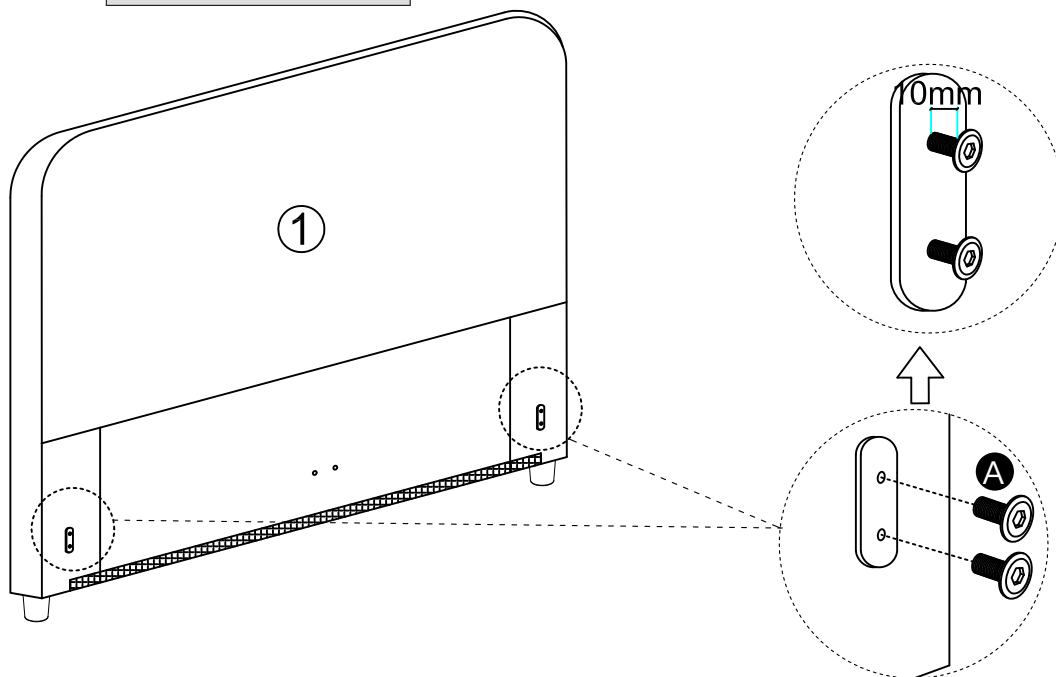
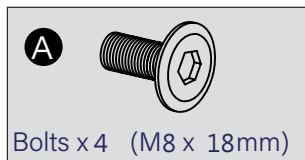

Install 4 x bolts 18 mm (A) to the holes in the headboard (1) as shown by hand.  
Note: Do not tighten fully but leave 10mm gap as in the diagram.

# Step 5

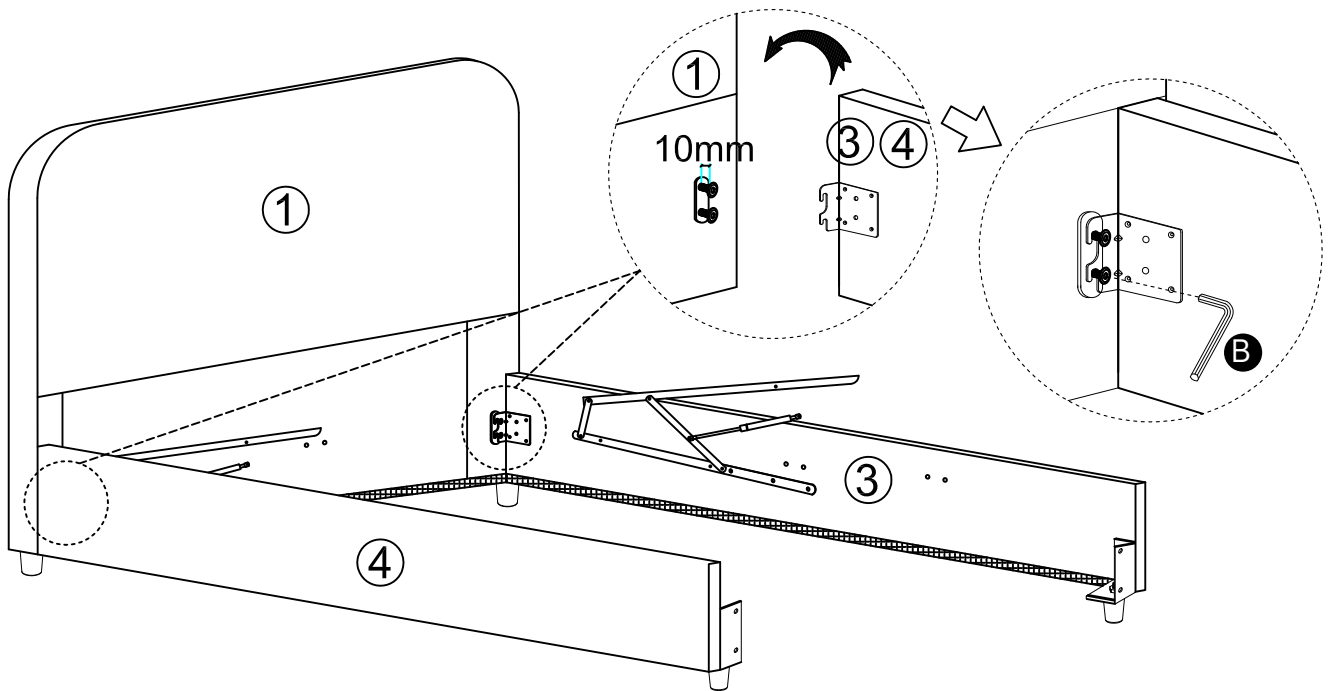
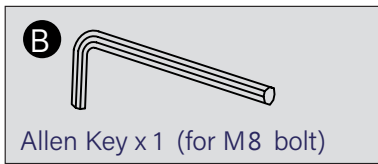

Attach side rails (3 and 4) to headboard (1) by Allen key (B) as shown.

# Step 6

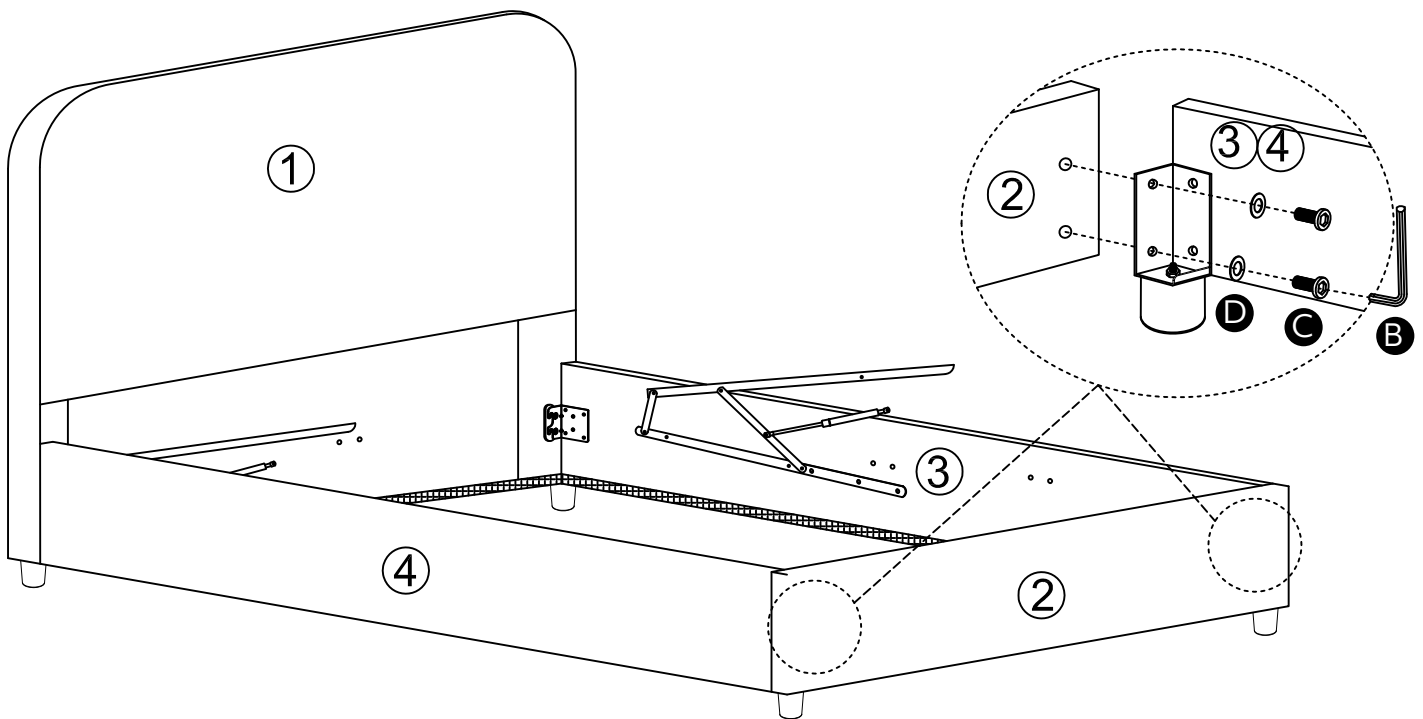
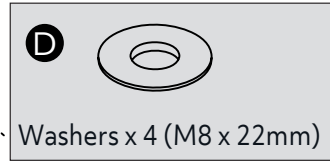
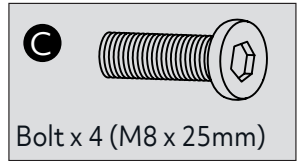
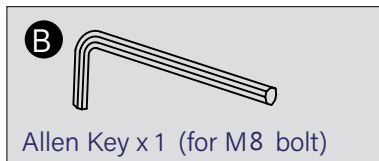

Attach side rails (3 and 4) to the footboard (2) with 4 X bolts 25mm (C) and 4 X washers (D) by Allen Key (B).



# Step 7

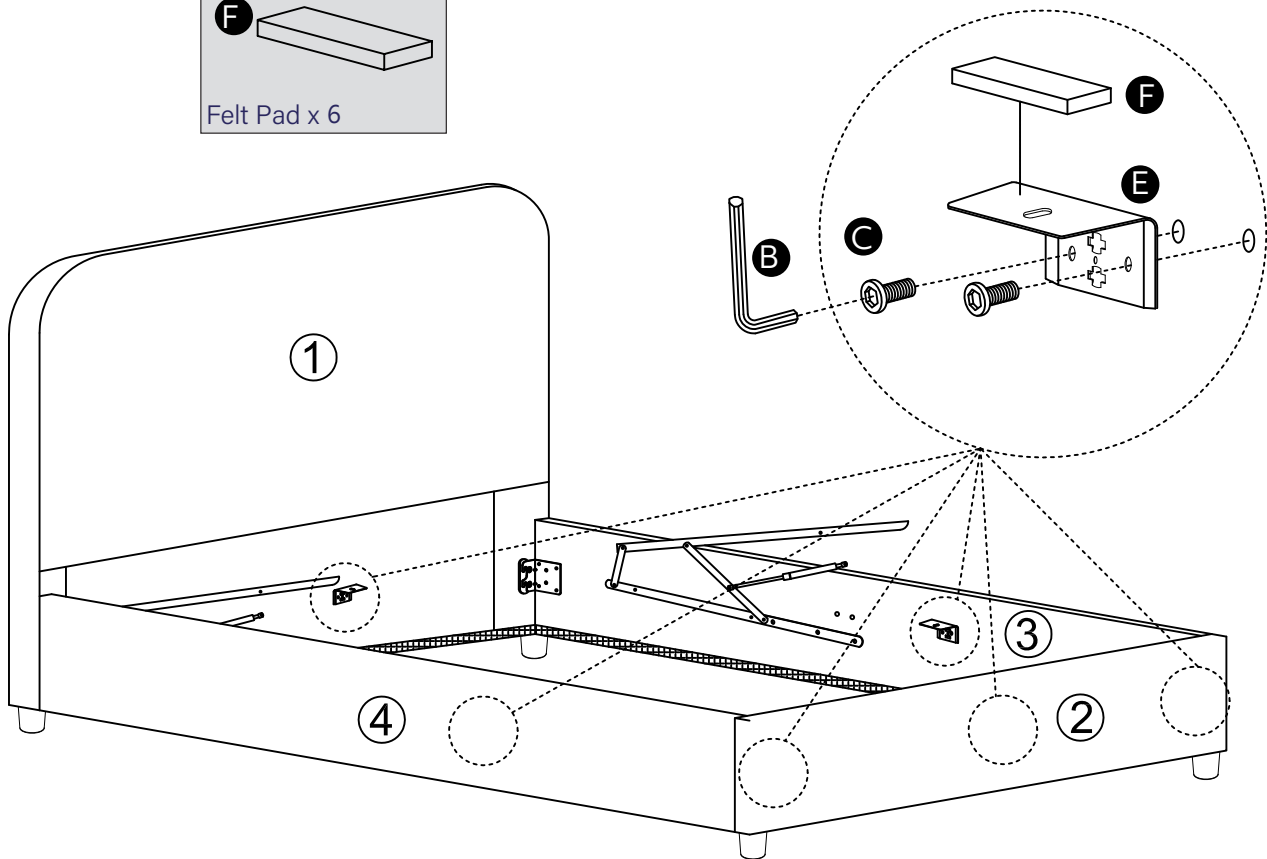
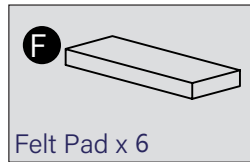
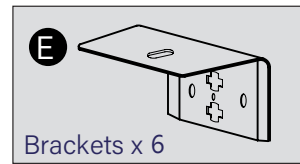
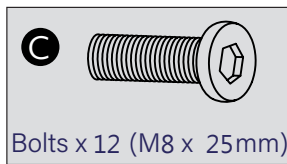
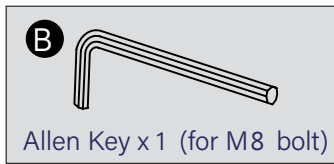

Attach 6 x brackets (E) to the headboard (1), side rails (3 and 4 ) and footboard (2) with 12 x bolts 25mm (C) by using Allen key(B).  
Stick the felt pad (F) on each top of bracket (E).

# Step 8

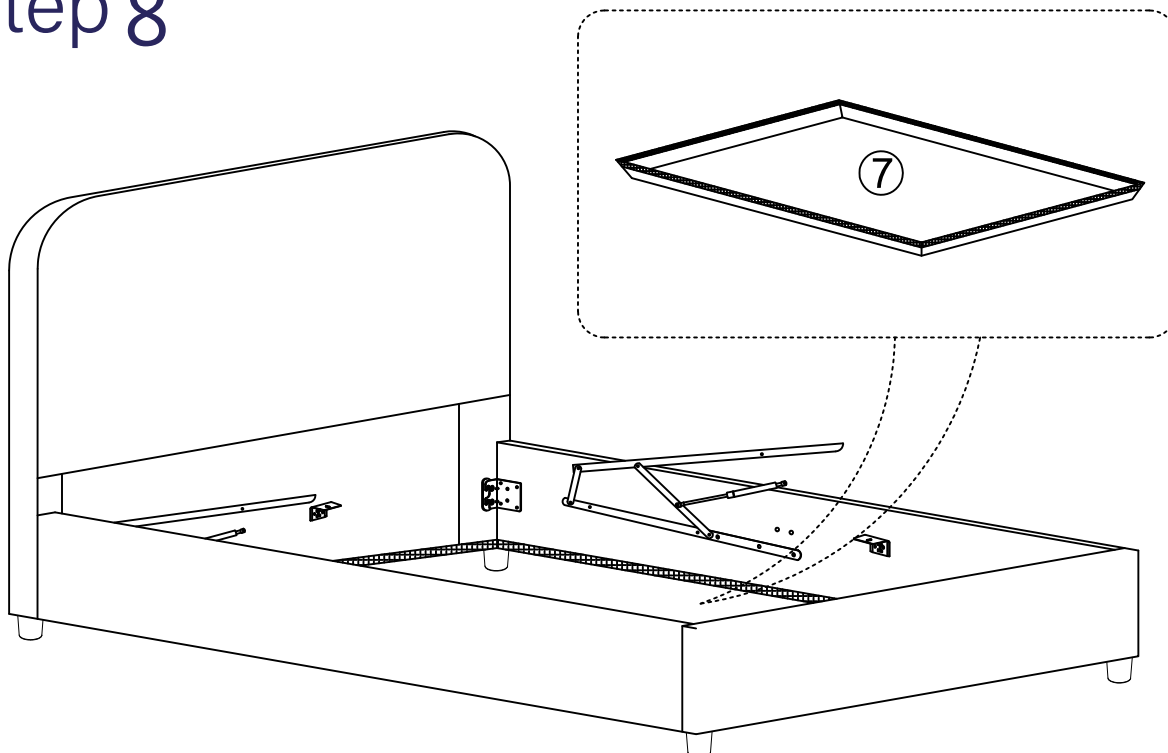

Put the baseboard (7) inside of bed. Attach the velcro to the four edges of frame.

# Step 9

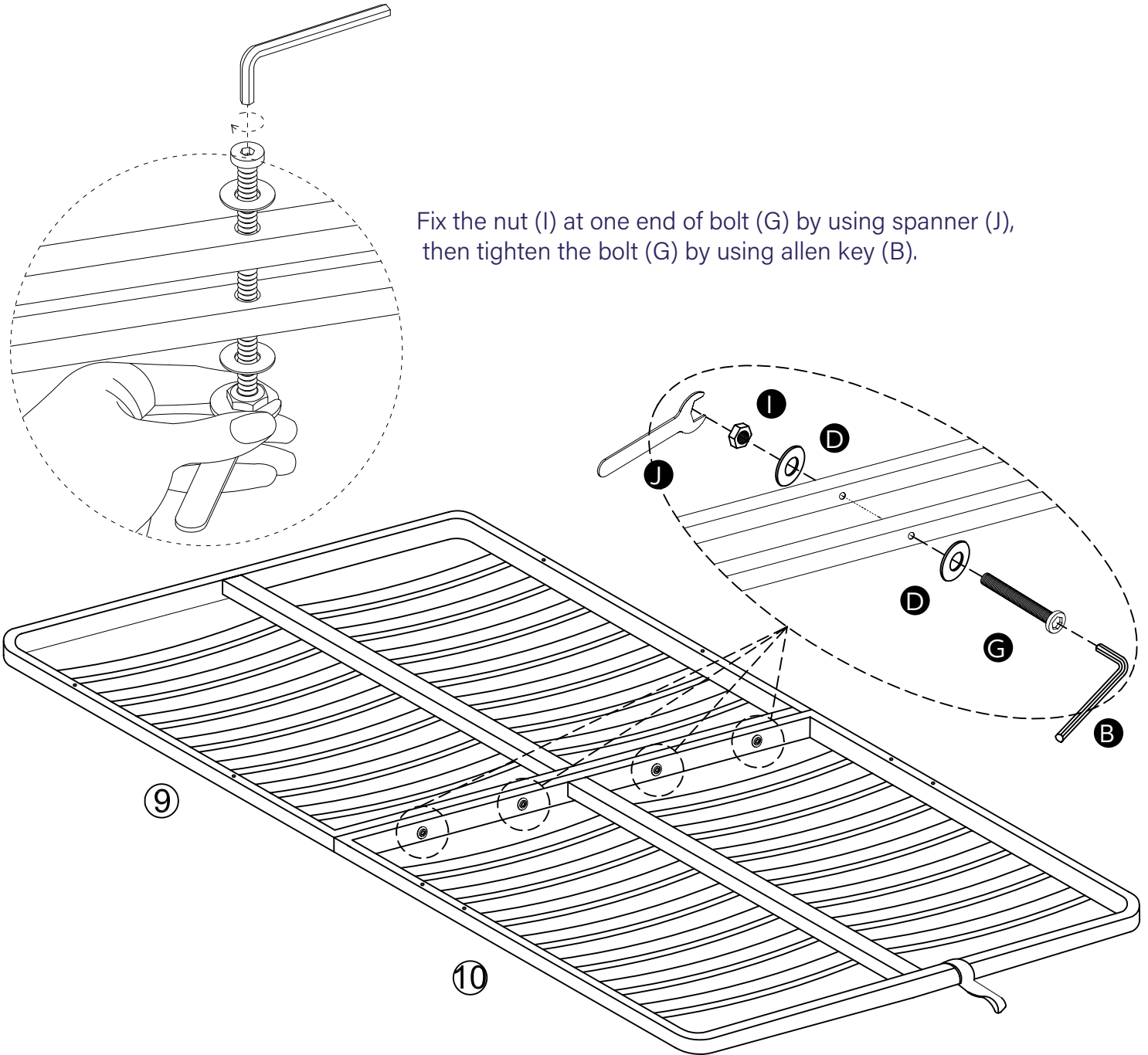
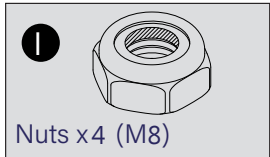
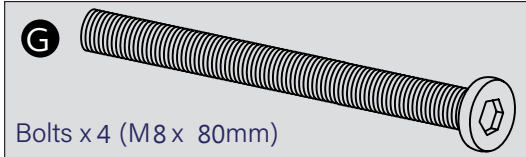
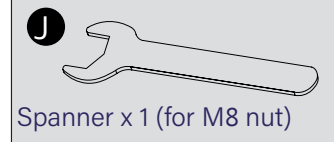
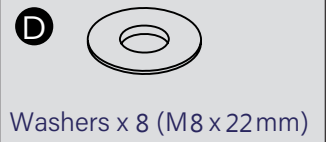
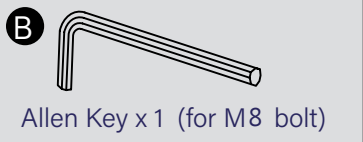

Fix the nut (I) at one end of bolt (G) by using spanner (J), then tighten the bolt (G) by using allen key (B).

Tighten both slat frame ( 9 and 10) together with 4 x bolts 80mm (G), 8x washers (D) and 4 x nuts (I) by using spanner (J) and allen key (B).

# Step 10

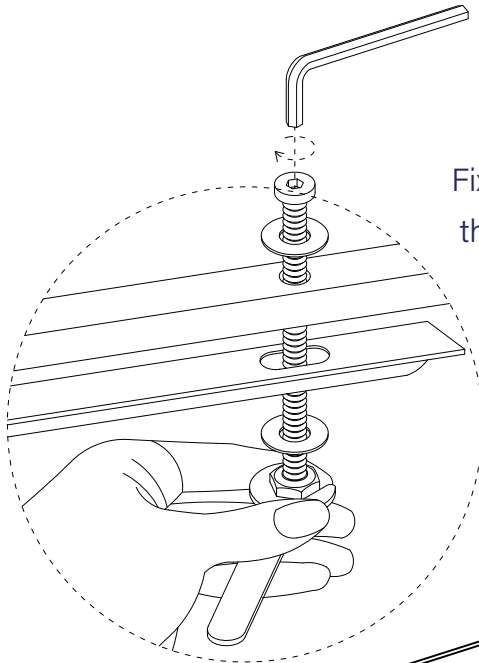
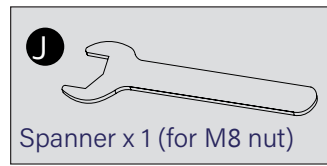
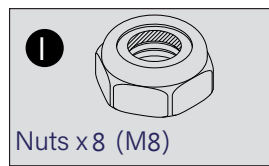
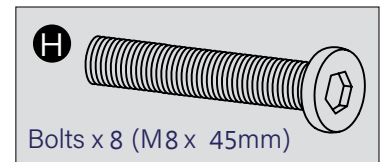
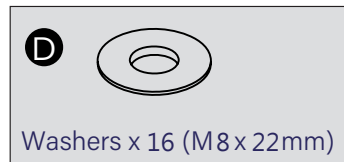
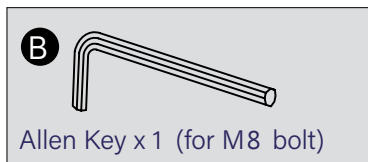

Fix the nut (I) at one end of bolt (H) by using spanner (J), then tighten the bolt (H) by using allen key (B).

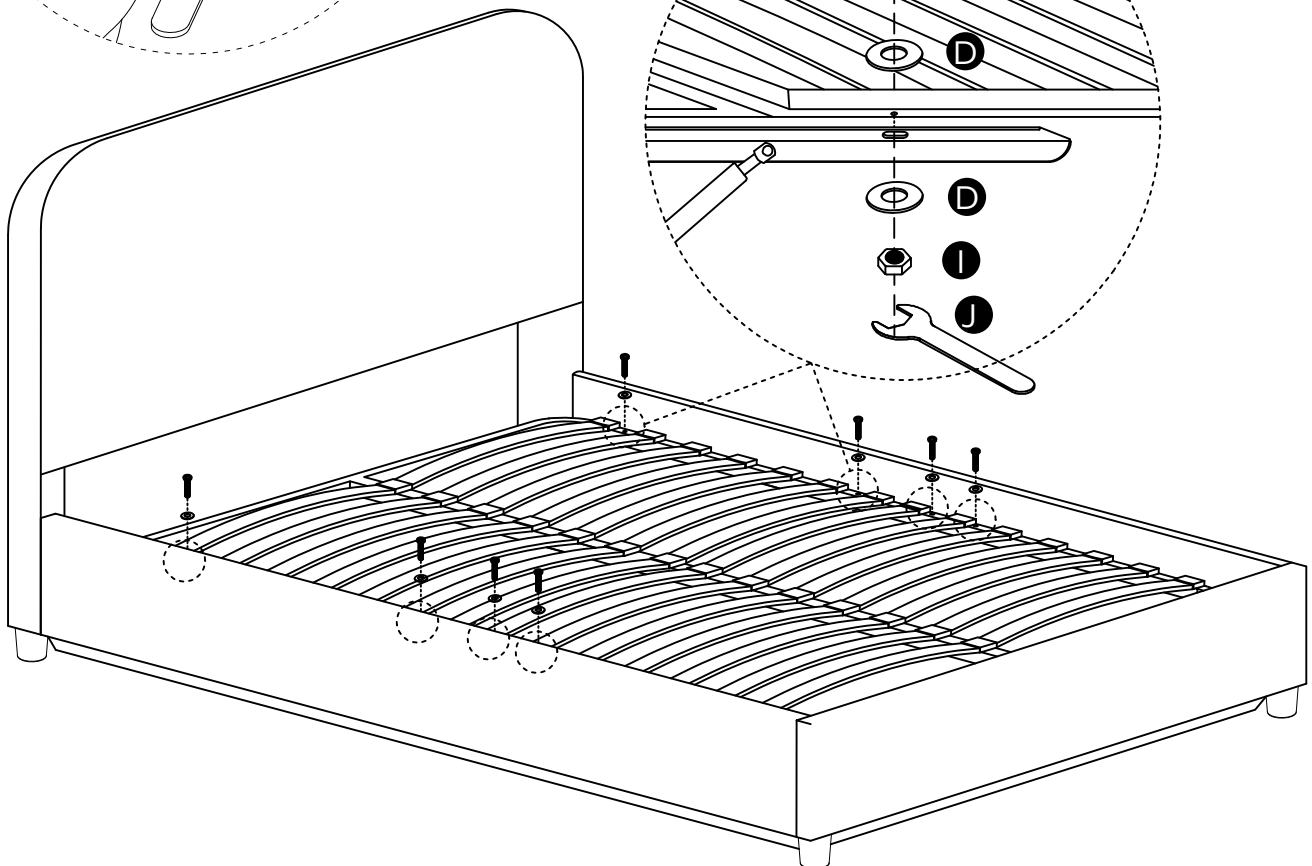
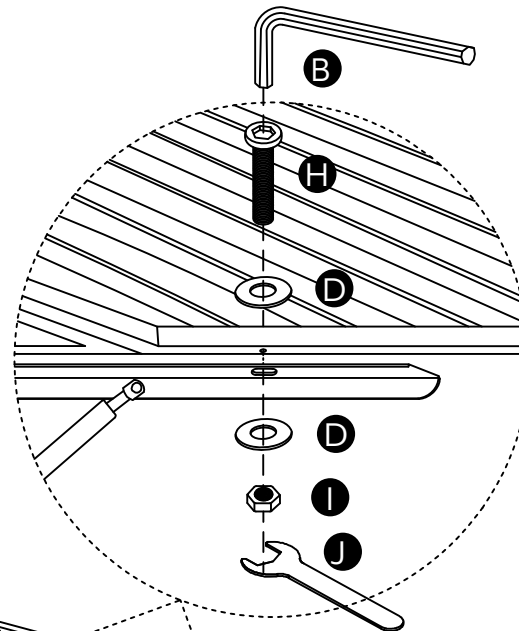

With help from your assistant, lift slat frame ( 9 and 10 ) onto slat frame support bars aligning first set of holes on the support bars ( nearest to headboard). Using 8 x bolts 45mm (H) , 16 x washers (D) and 8 x nuts (I) by allen key (B) and spanner (J) . Ensure slat frame ( 9 and 10 ) is central with even gaps all around before fully tightening all bolts.

# Step 11

Un-tie each mechanism, take out the transit protection block  
Tilt the arms upwards, slat frame support bar.  
Tighten all nuts and washers on the arms.

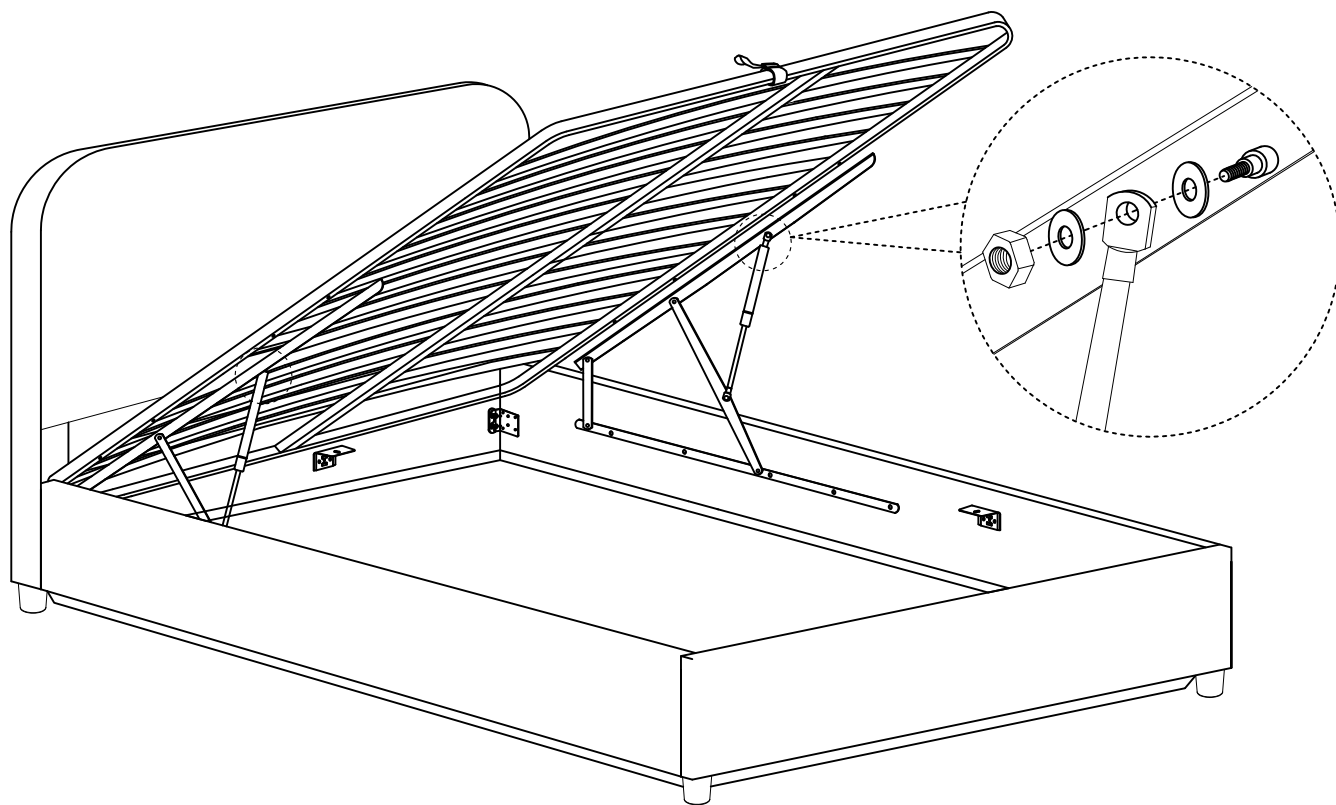

# Step 12

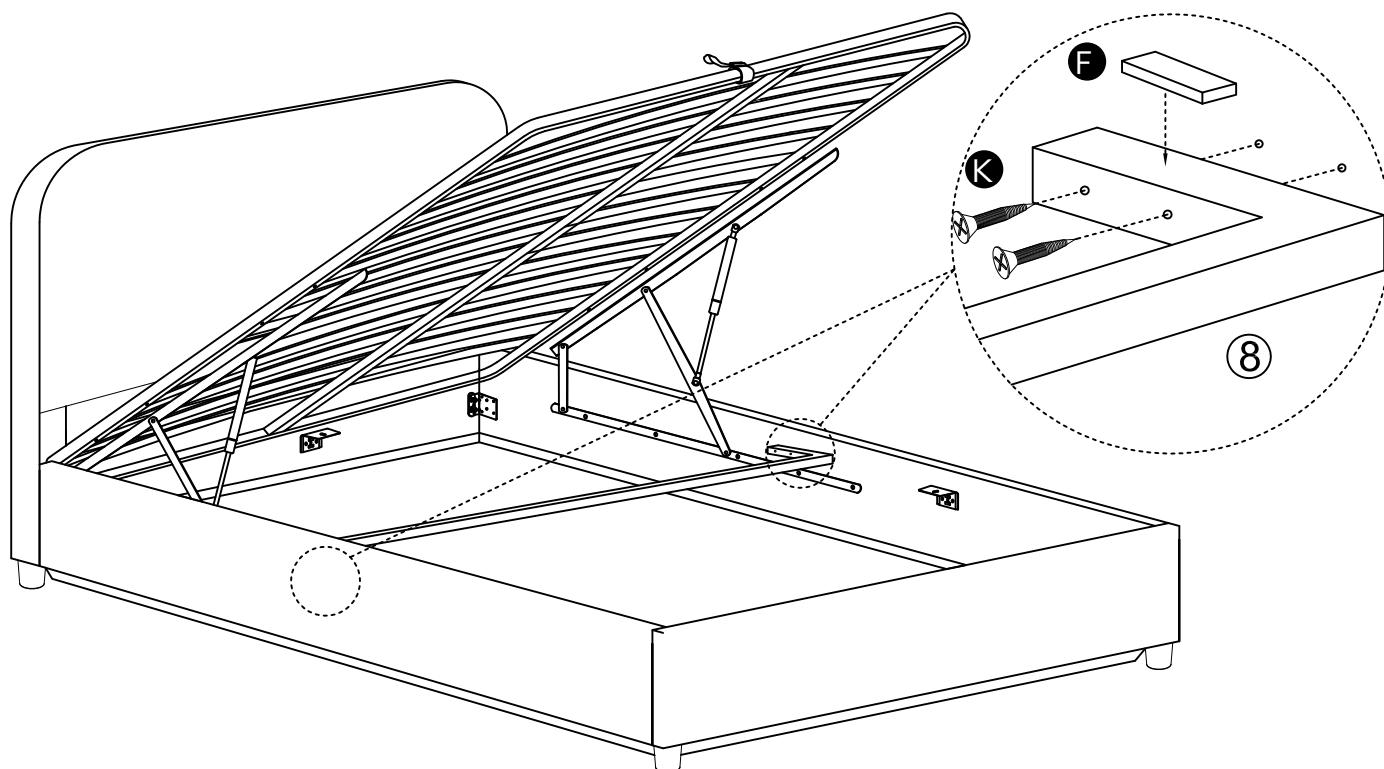
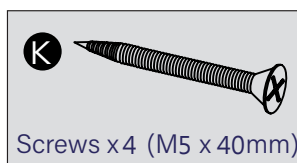
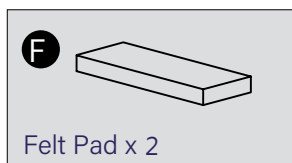

Tighten the center supporter(8) to the side rails (3 and 4) with 4 x screws (K) by using phillips head screwdriver (not provided). Stick the felt pad (F) on the top of end of center supporter (8).

# Step 13

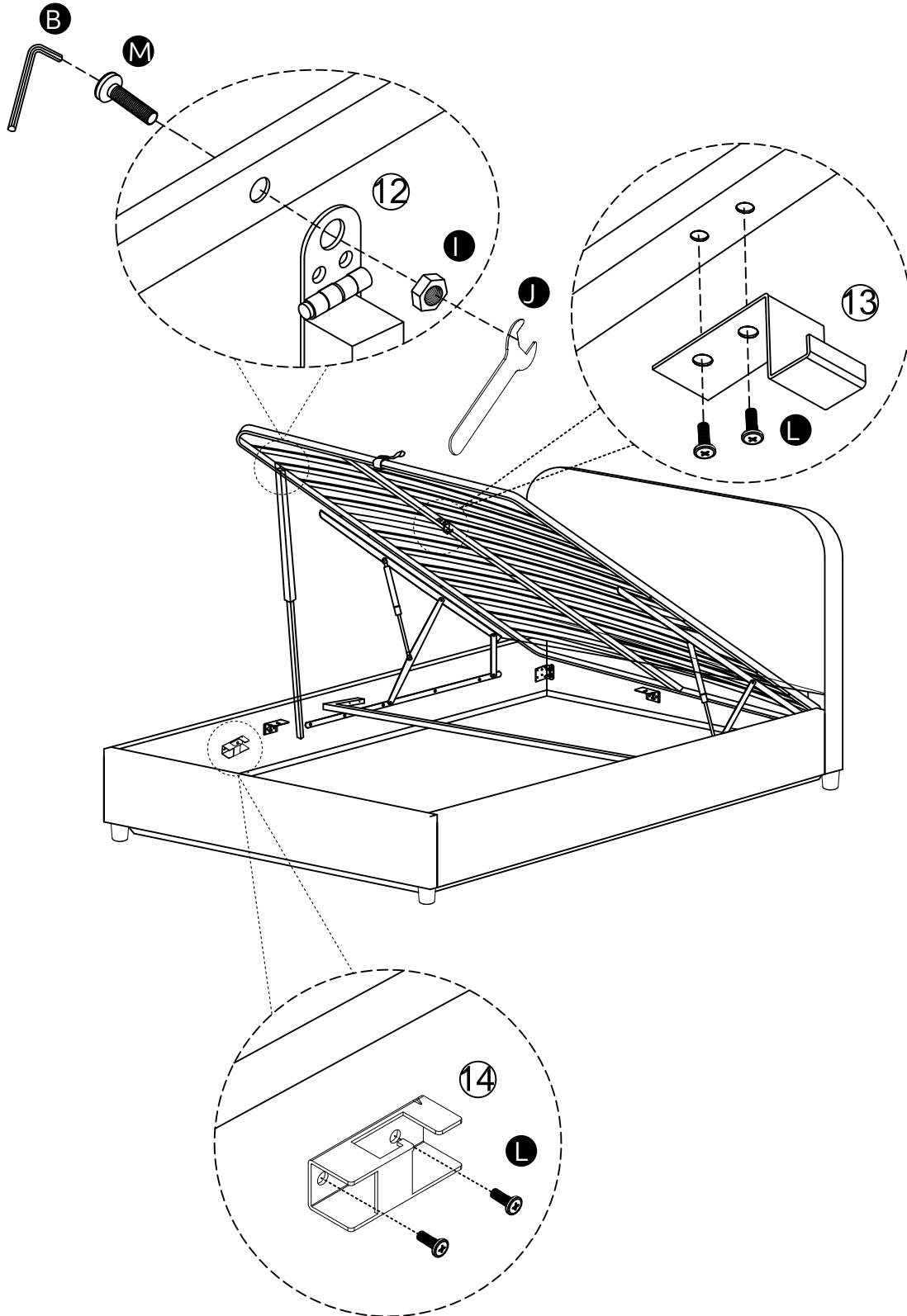
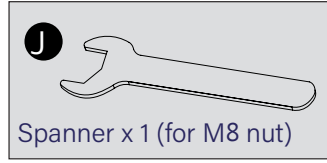
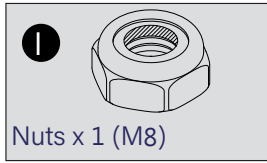
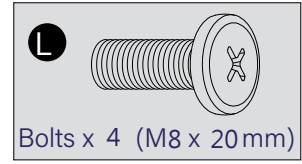
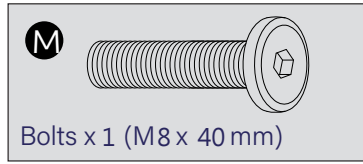
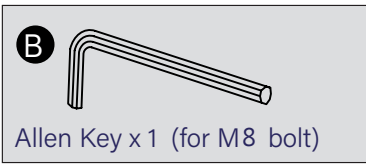

The bracket (14) must be assembled on the left side rail(4).

# Step 14

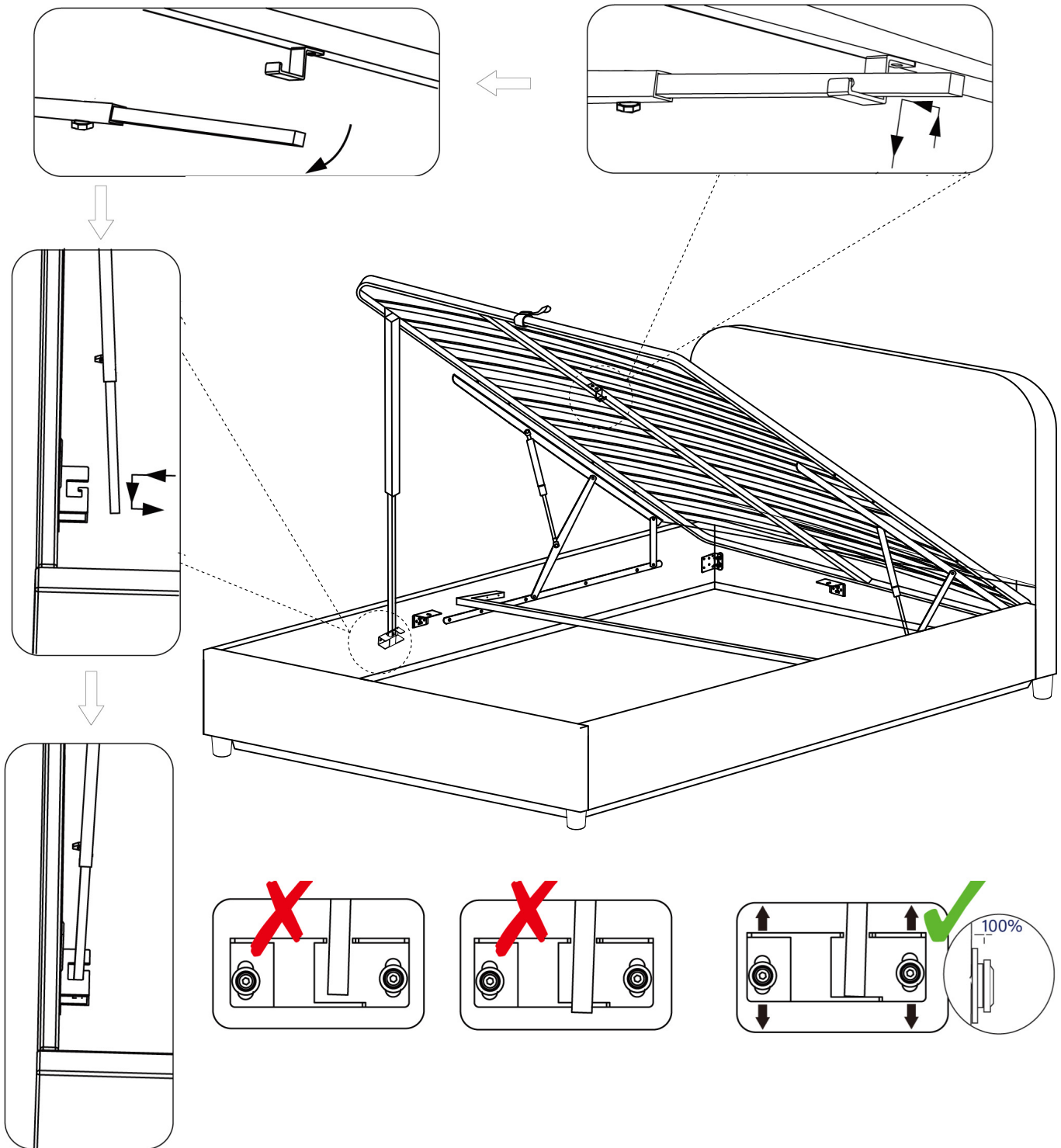

# Step 15

Put mattress holders (11) on the slat frame shown in the diagram.

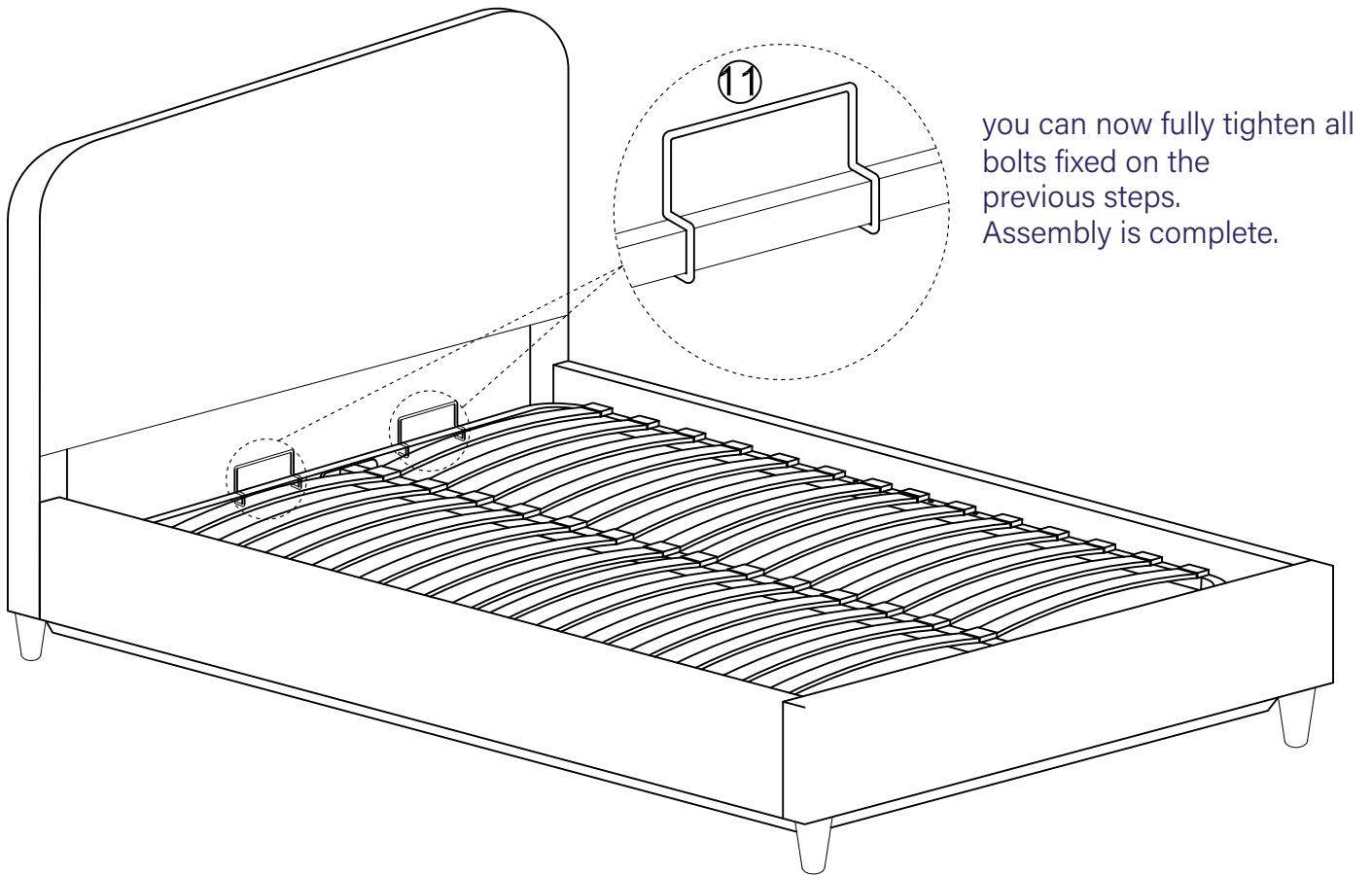

Depending on the weight of the mattress, the rising speed will vary so be careful until you get used to the speed. Always use the strap to lift or lower the frame - keep fingers well away from the moving parts.

NOTE: When fully assembled and the mattress is in position, please raise and lower the ottoman 4 / 5 times to ensure the gas pistons are fully lubricated.

## IMPORTANT OTTOMAN SAFETY WARNINGS

- IMPORTANT – READ CAREFULLY – RETAIN FOR FUTURE REFERENCE
- You must ensure that the mattress is on the bed frame before operating the lift mechanism – Failure to do so could result in injury.
- Keep hands clear of the mechanism when opening or closing the ottoman.
- Beware of entrapment – Never reach in through the mechanism to access the storage area.
- Always ensure that the ottoman is FULLY opened before accessing the storage area.
- Do not reach into the storage area through the hinge mechanism.
- Do not exceed the maximum weight as specified in the table below:



Bed	Bed Size	Min Weight (kg)	Max Weight (kg)
Johnson bed	Double	20	40
	King	20	40

- Use caution when operating, always use the handle when lifting
- Note: This bed uses a pressurised mechanism.
- To be operated by adults only
- Please ensure that children and pets are kept away from the bed when operating the lift mechanism.
- Keep children and pets away from the storage area.
- No children or animals are left unattended when the frame is in the ' up' position.
- Do not overload the internal storage base.
- Do not stand inside the internal storage area of the bed
- Before removing the mattress secure the frame to ensure it does not open unexpectedly.
- Do not attempt to lie on the mattress when the ottoman is in the raised position.
- When lifting the ottoman remove all bedding except the fitted sheet.
- Depending on the weight of the mattress, the rising speed will vary so be careful until you get used to the speed.
- NOTE: When fully assembled and the mattress is in position, please raise and lower the ottoman 4 / 5 times to ensure the gas pistons are fully lubricated.



# Care and maintenance

Here are some tips to keep your new bed in tip-top condition



## Cleaning

To clean your new bed, we'd advise using a warm damp cloth or if fabric, remove dust using a low suction vacuum cleaner - please do not use abrasive chemicals or bleach as this may damage the product.



## Checking and moving

Periodically we recommend you check that the screws or fixtures haven't become loose over time. To move your new bed, we recommend lifting it where possible, as dragging or pushing it could cause damage to the legs or flooring.



## Wood

Please note each of our wooden pieces are unique, meaning that markings and shade can vary slightly between beds. Over a period of time, the wood might lighten or fade slightly due to light exposure.



## Fabric

Please note depending on the lighting, positioning and surroundings of your room, the shade of the colour can sometimes appear slightly different. Over a period of time, the colour might lighten or fade slightly due to light exposure.



## Metal

Metal tends to be more resilient to everyday wear and tear. We recommend to gently dust your metal furniture and keep it dry to maintain its look.

**Thank you for shopping with us - we hope you have a great night's sleep**

*Sleep well*



# Little dreamers

Keep the little ones entertained while you assemble your new purchase.

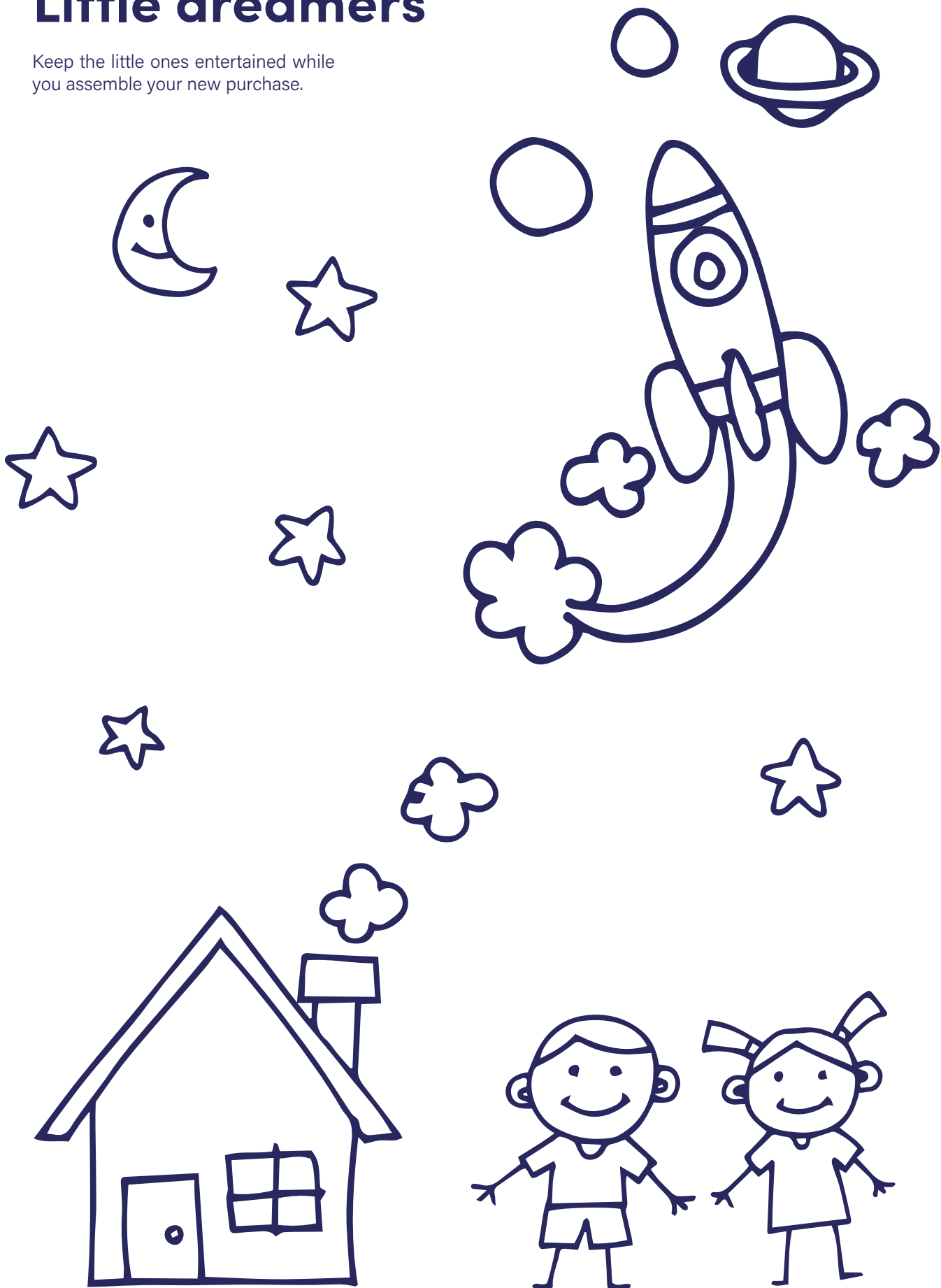

# Dreams