

PLEASE READ this sheet prior to assembly to familiarise yourself with the various stages of construction. Carefully open the pack supplied and check the contents against the parts and fittings check list.

Do not destroy any of the packaging until you are certain that you have all the necessary parts for the assembly.

Please ensure that the packaging is disposed of in a safe environmentally friendly way.

CAUTION: There are small components used in the construction of this unit. These loose items should be kept away from young children during assembly, to avoid the danger of choking.

**IMPORTANT: BEFORE STARTING TO ASSEMBLE THE BED - PLEASE READ THESE INSTRUCTIONS CAREFULLY**

## Parts Identification

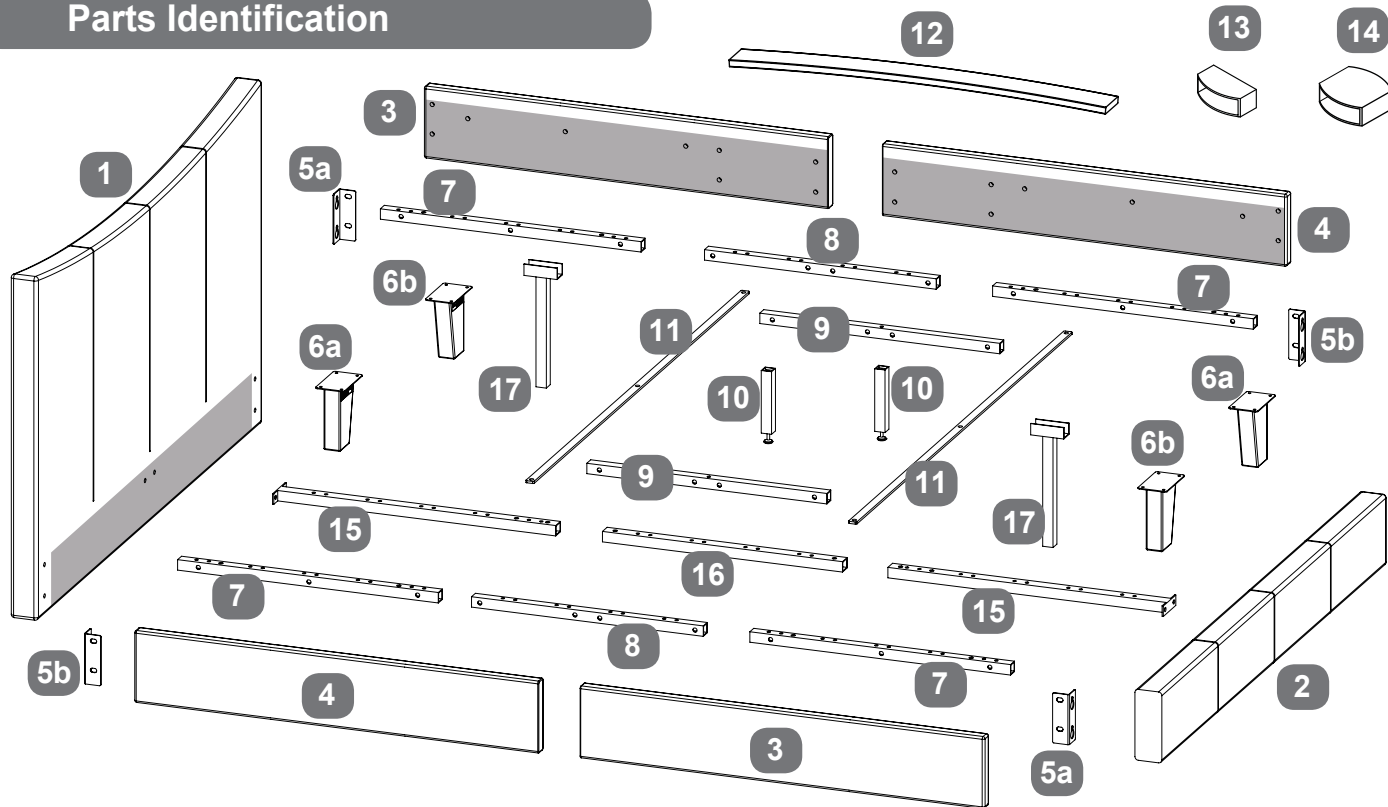





## Parts Checklist



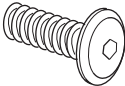
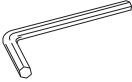

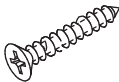
Ref.	Description	Qty	Ref.	Description	Qty
1	Headboard	1	10	Side Panel Support Legs	2
2	Footboard	1	11	Cross Bars	2
3	Side Panels - Left Hand	2	12	Wooden Slats	Single/Double Bed 14/28
4	Side Panels - Right Hand	2	13	Single Plastic Caps	Single or Double Bed 28
5a&5b	Corner Connection Brackets	2 Pr	*14	Double Plastic Caps	14
6a&6b	Feet	2 Pr	*15	Centre Support Bars - End	2
7	Side Panel Support Rails - End	4	*16	Centre Support Bar - Centre	1
8	Side Panel Support Rails - Centre	2	*17	Centre Support Bar Legs	2
9	Side Panel Connecting Rails	2		*Only for Double Size Bedstead	

## Fittings Checklist

### HARDWARE NEEDED FOR CORNER BRACKET AND FEET ASSEMBLY (PACK A)

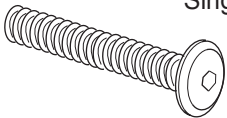

Code	Description	Qty	Code	Description	Qty
A	Bolts (M8x25mm) for fitting bracket (5a&5b) to headboard & footboard (1&2) and to side panels (3&4)	 x16	D	Allen Key (for M8 bolt)	 x1
B	Spring Washers (for M8 bolts)	 x16	E	Screws (4x25mm) for fitting feet (6a&6b) to headboard & footboard (1&2).	 x16
C	Flat Washers (for M8 bolts)	 x16			

### HARDWARE NEEDED FOR SIDE PANEL ASSEMBLY (PACK B)

Code	Description	Qty	Code	Description	Qty
C	Flat Washers (for M8 bolts)	 Single x38 Double x42	G	Nuts for (for M8 Bolts)	 Single x4 Double x6
F	Bolts (M8x45mm) for fitting support bar & cross bar (11) to side panels (3&4)	 Single x34 Double x36	H	Spanner (for M8 Nut)	 x1

### HARDWARE NEEDED FOR CENTRE SUPPORT BAR ASSEMBLY (PACK C)

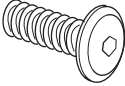
\*Only for Double Size Bedstead

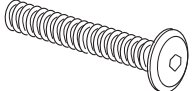
Code	Description	Qty	Code	Description	Qty
A	Bolts (M8x25mm) for fitting centre support bar (15) to headboard & footboard (1&2)	 x4	G	Nuts for M8 Bolts	 x4
C	Flat Washers (for M8 bolts)	 x8	F	Bolts (M8x45mm) for fitting centre support bar leg (17) to centre support bar (15&16)	 x4

### Additional Tools Required

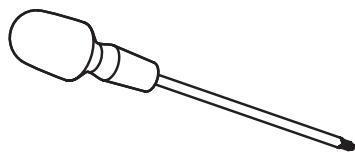

Crosshead Screwdriver

### Care & Maintenance

In the unlikely event of missing or damaged parts, please contact the customer service team on; 0344 292 00 00. When calling this number please quote the part code reference numbers shown in this leaflet, when requesting spare or replacement parts.

### General Hints & Tips



Please retain your assembly instruction and tools provided for future use. Periodically check that all bolts are still tight.



Assembly requires two persons.



1 Hr

Approximate time to assemble this product

## Side Panel Assembly - Use Pack 'A'

Stage

1

x2

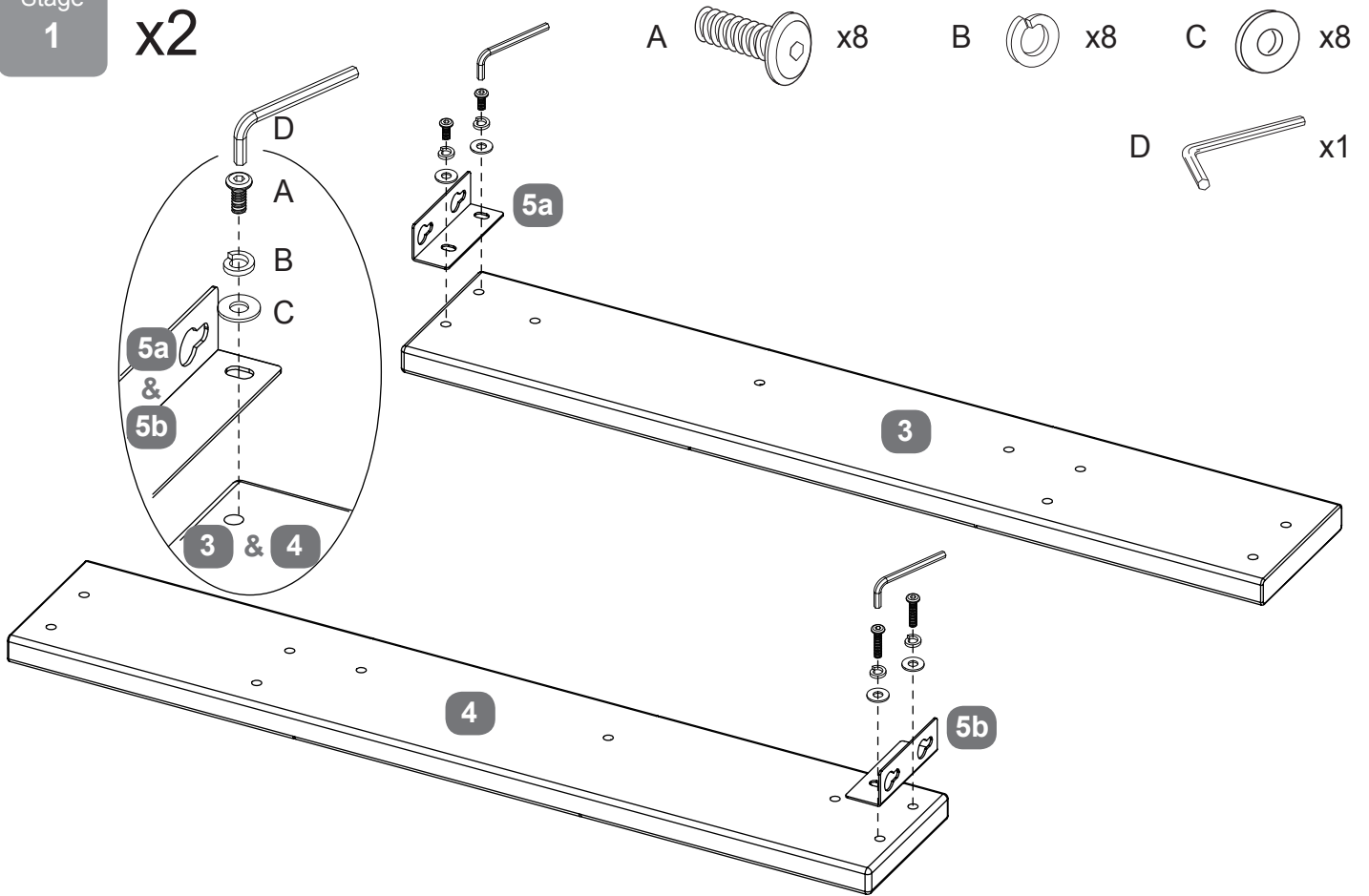

## Side Panel Assembly - Use Pack 'B'

Stage

2

x2

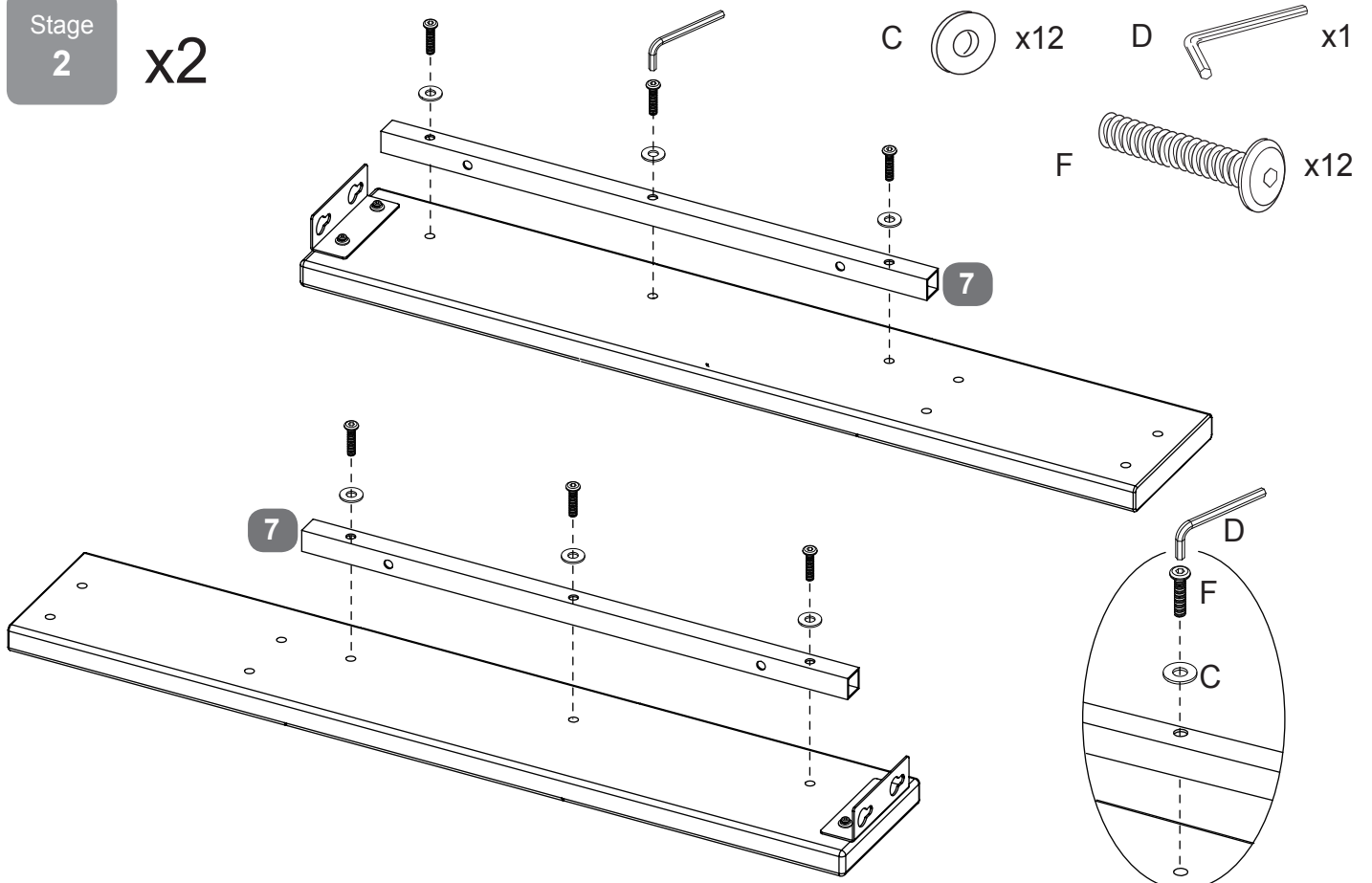

# Side Panel Assembly - Use Pack 'B'

Stage

3

x2

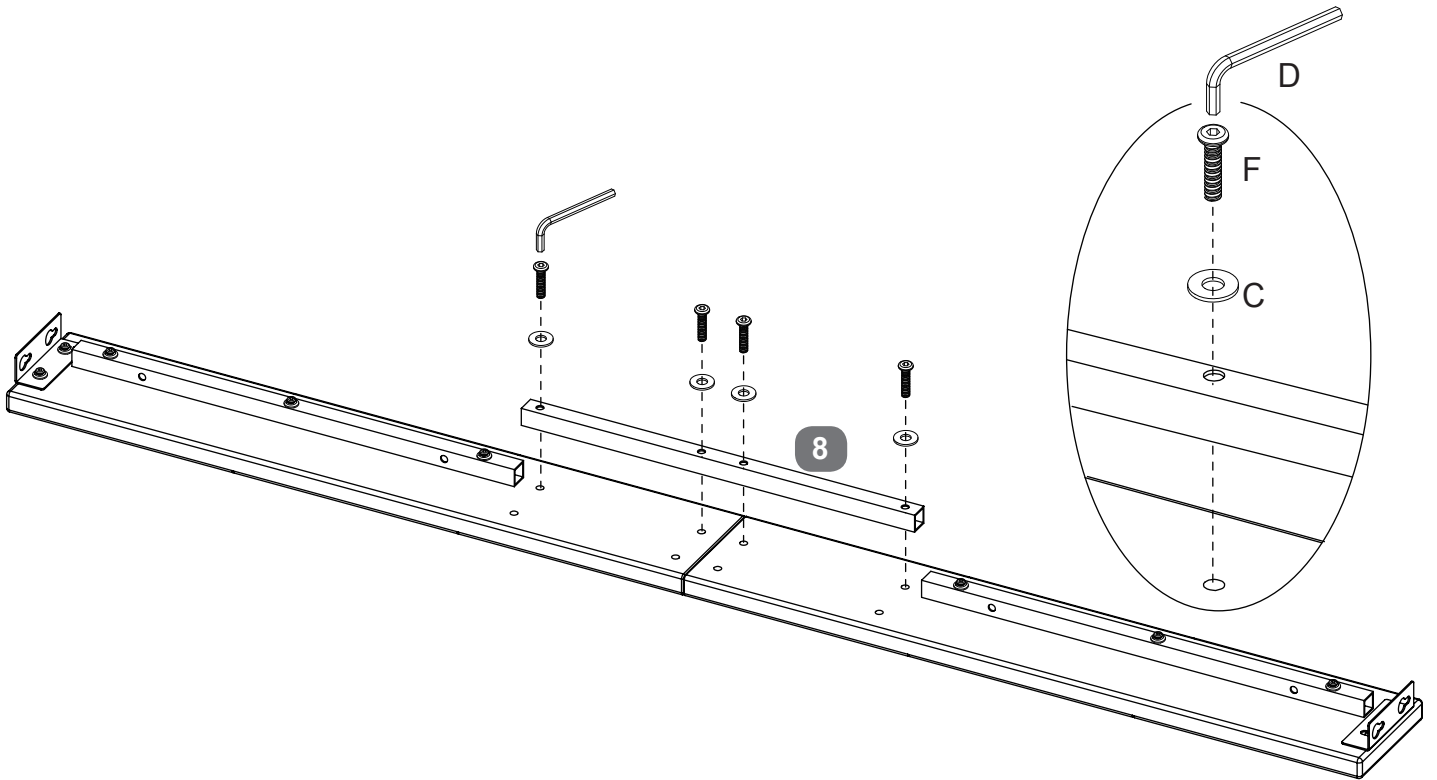
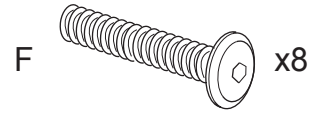
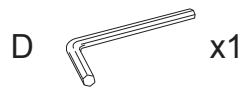

# Side Panel Assembly - Use Pack 'B'

Stage

4

x2

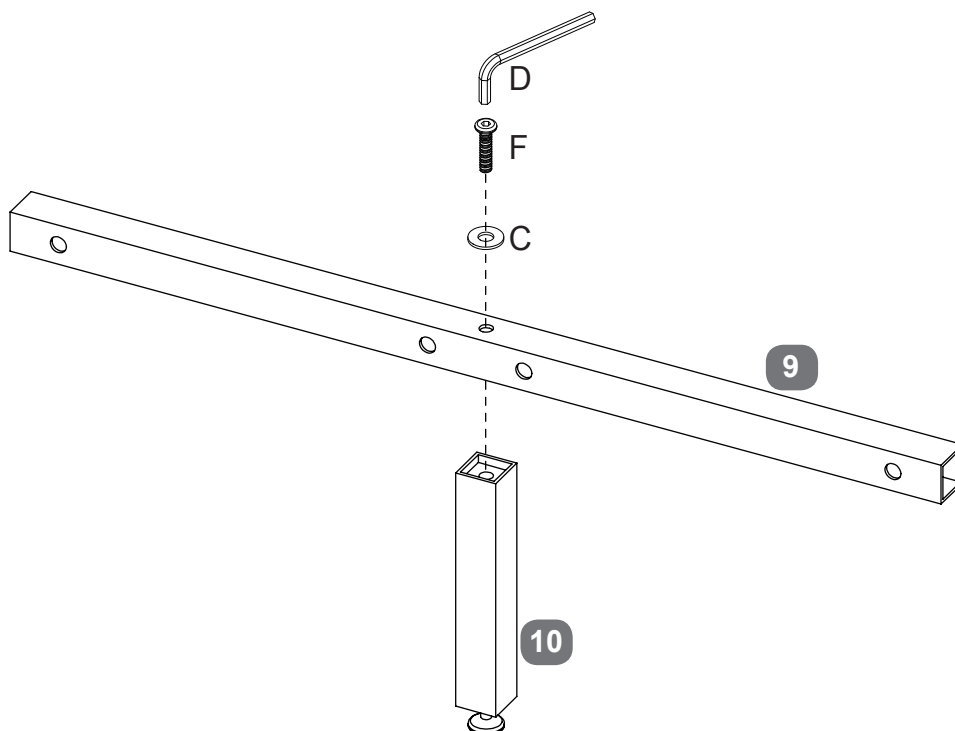
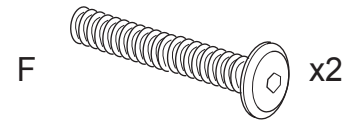
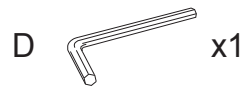

# Side Panel Assembly - Use Pack 'B'

Stage

5

x2

C  x8

D  x1

F  x8

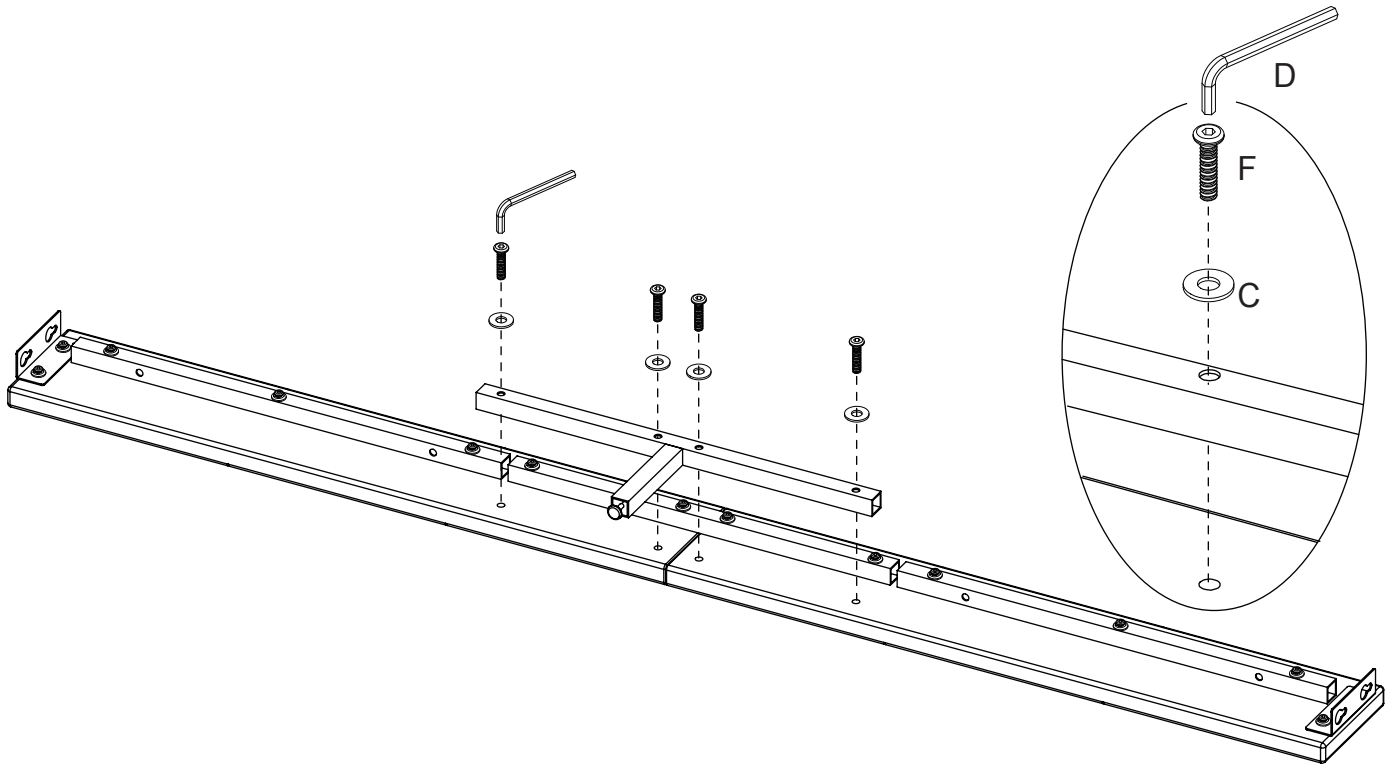

# Centre Support Bar Assembly - Use Pack 'C'

Stage

6

DOUBLE SIZE

C  x8

D  x1

F  x4

G  x4

H  x1

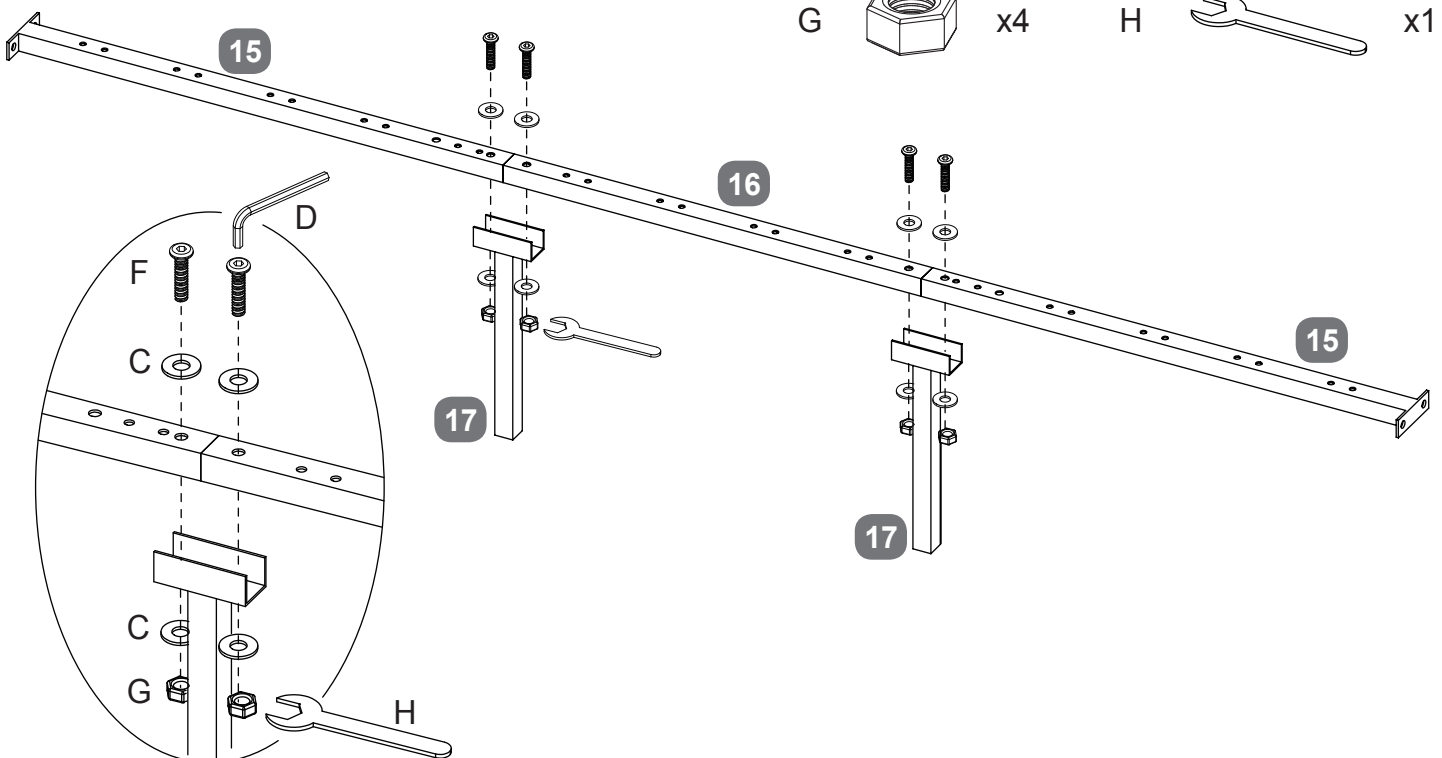

# Bed Assembly - Use Pack 'A'

Stage  
7

- A  x8
- B  x8
- C  x8
- D  x8

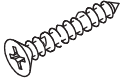
- E  x16

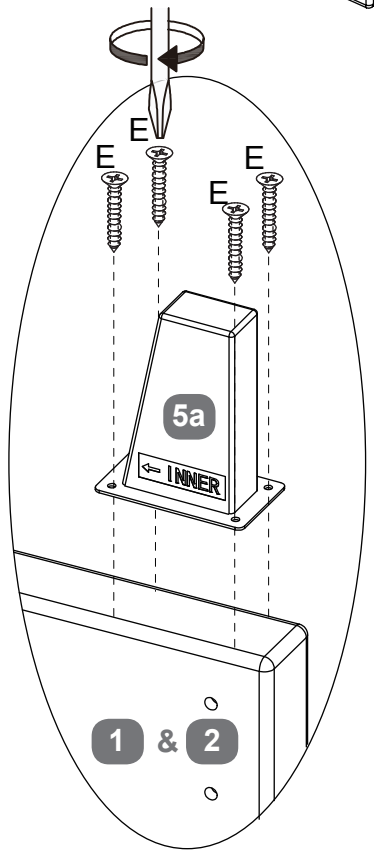
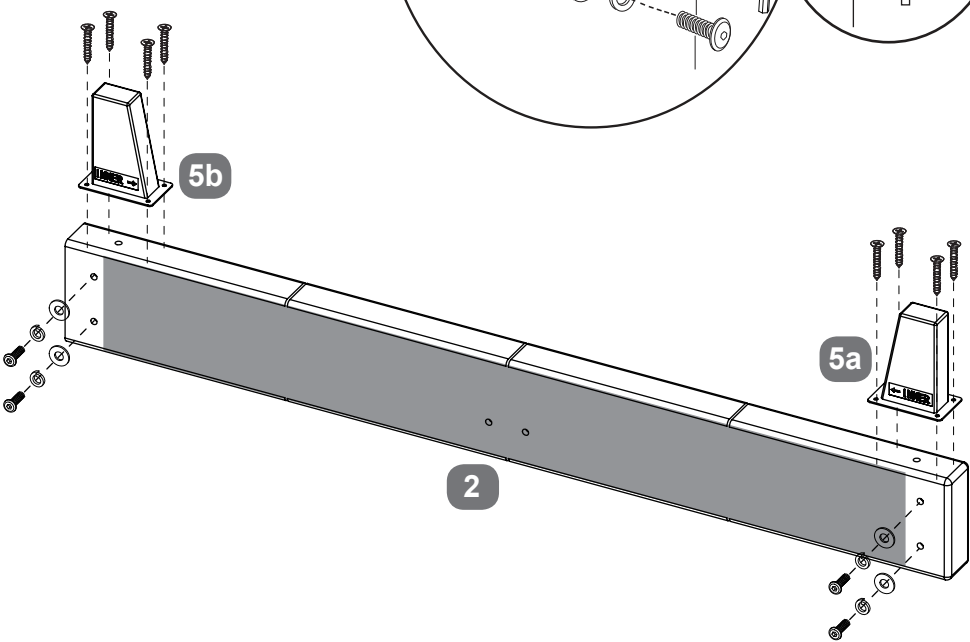
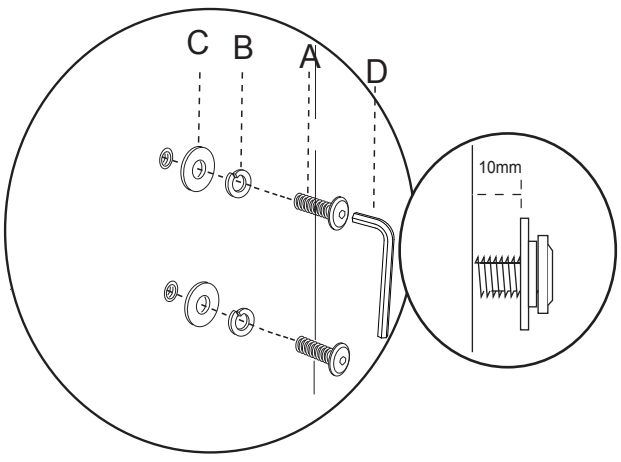
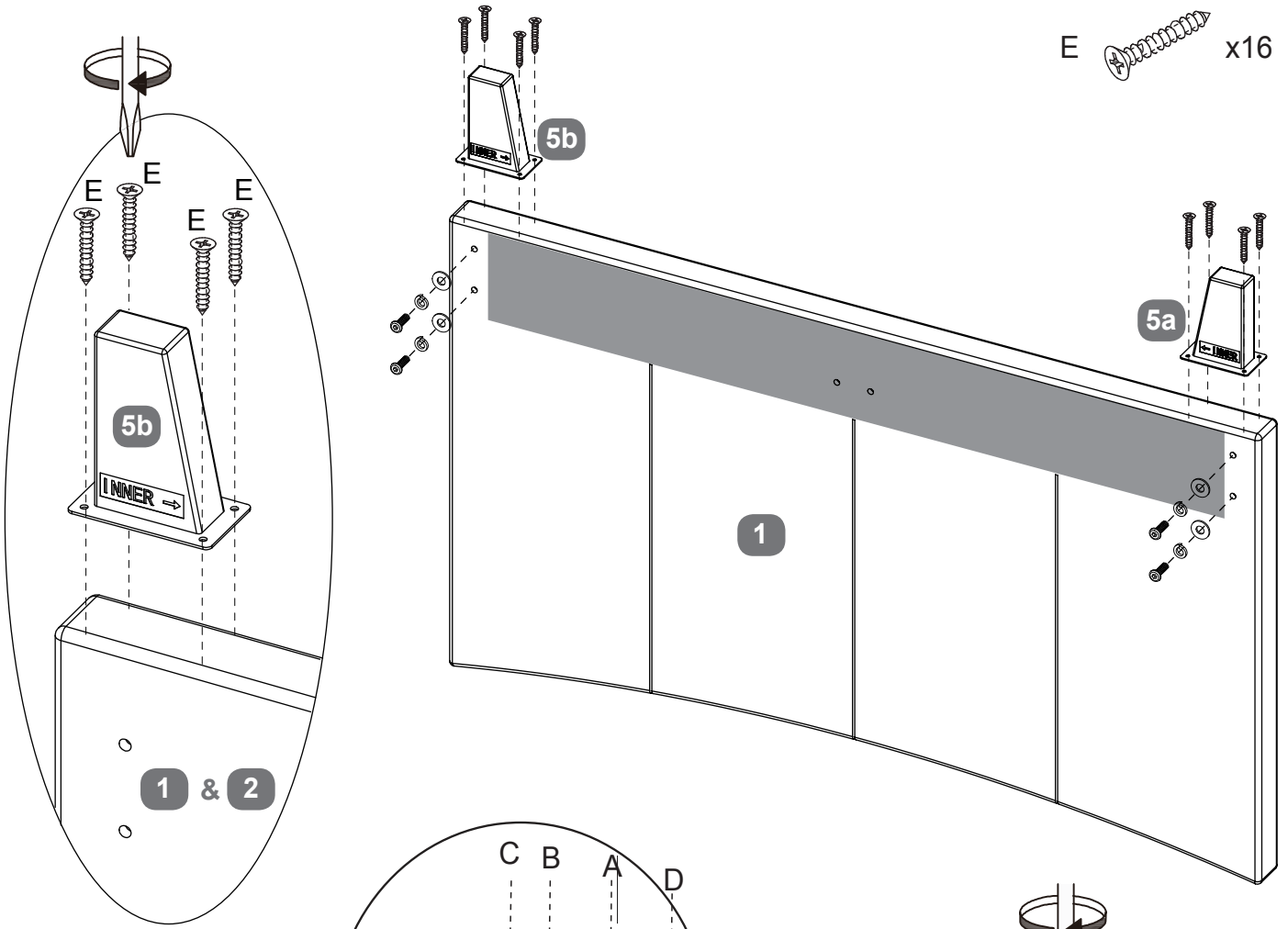

# Bed Assembly - Use Pack 'C'

Stage  
8a

DOUBLE SIZE

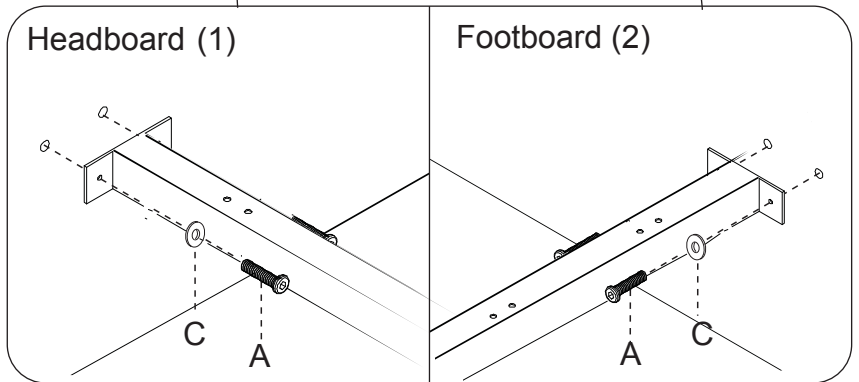
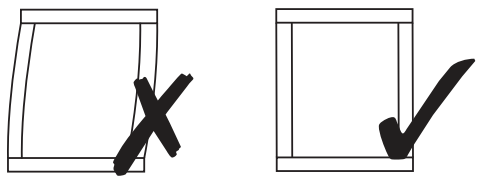
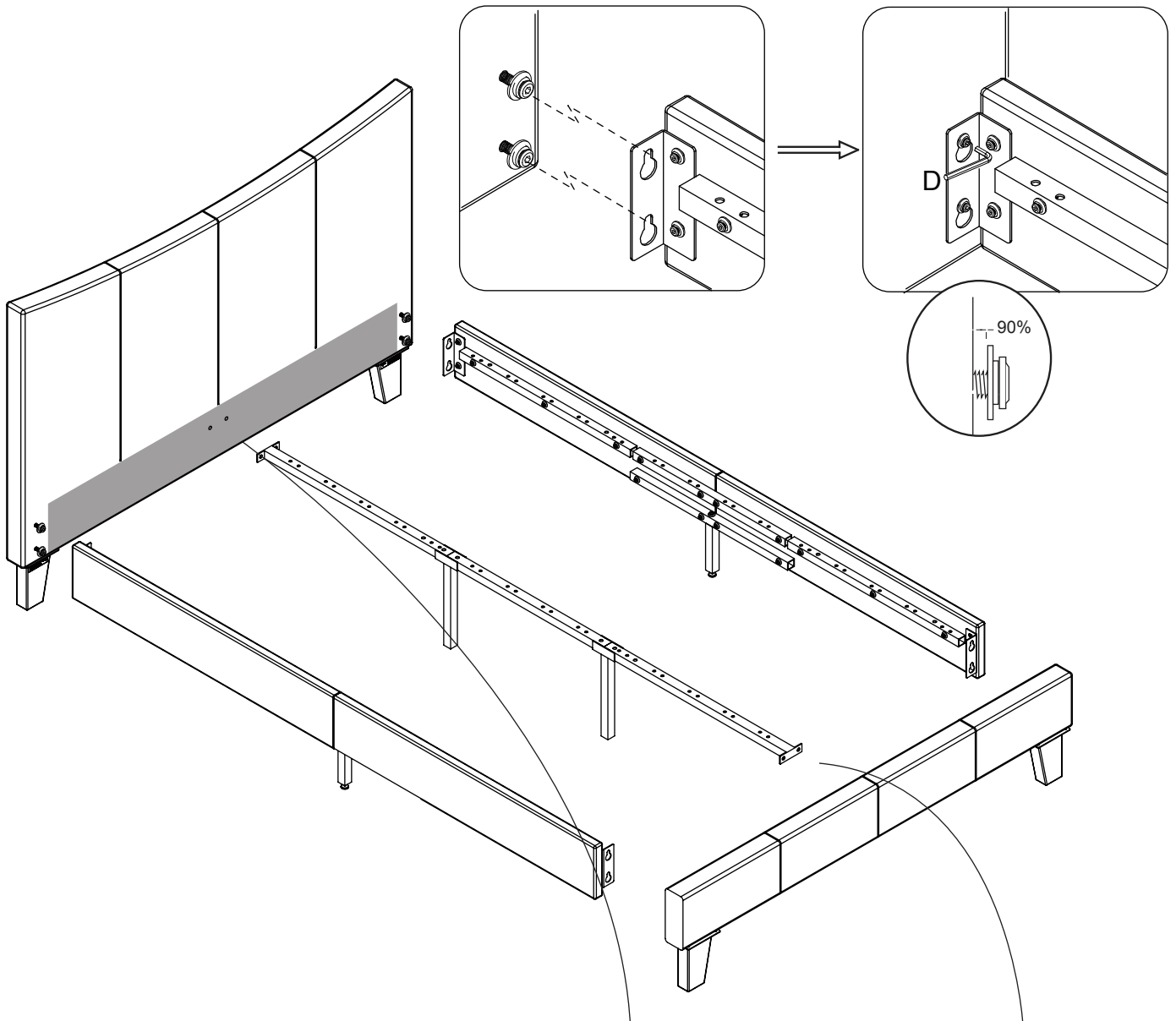
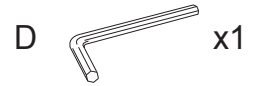
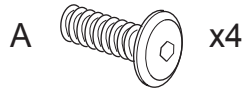

Make certain the bed is squared up as shown in the diagram then tighten all bed assembly bolts 100%.

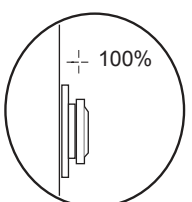

# Bed Assembly - Use Pack 'A'

Stage  
8b

SINGLE SIZE

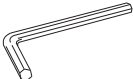
D  x1

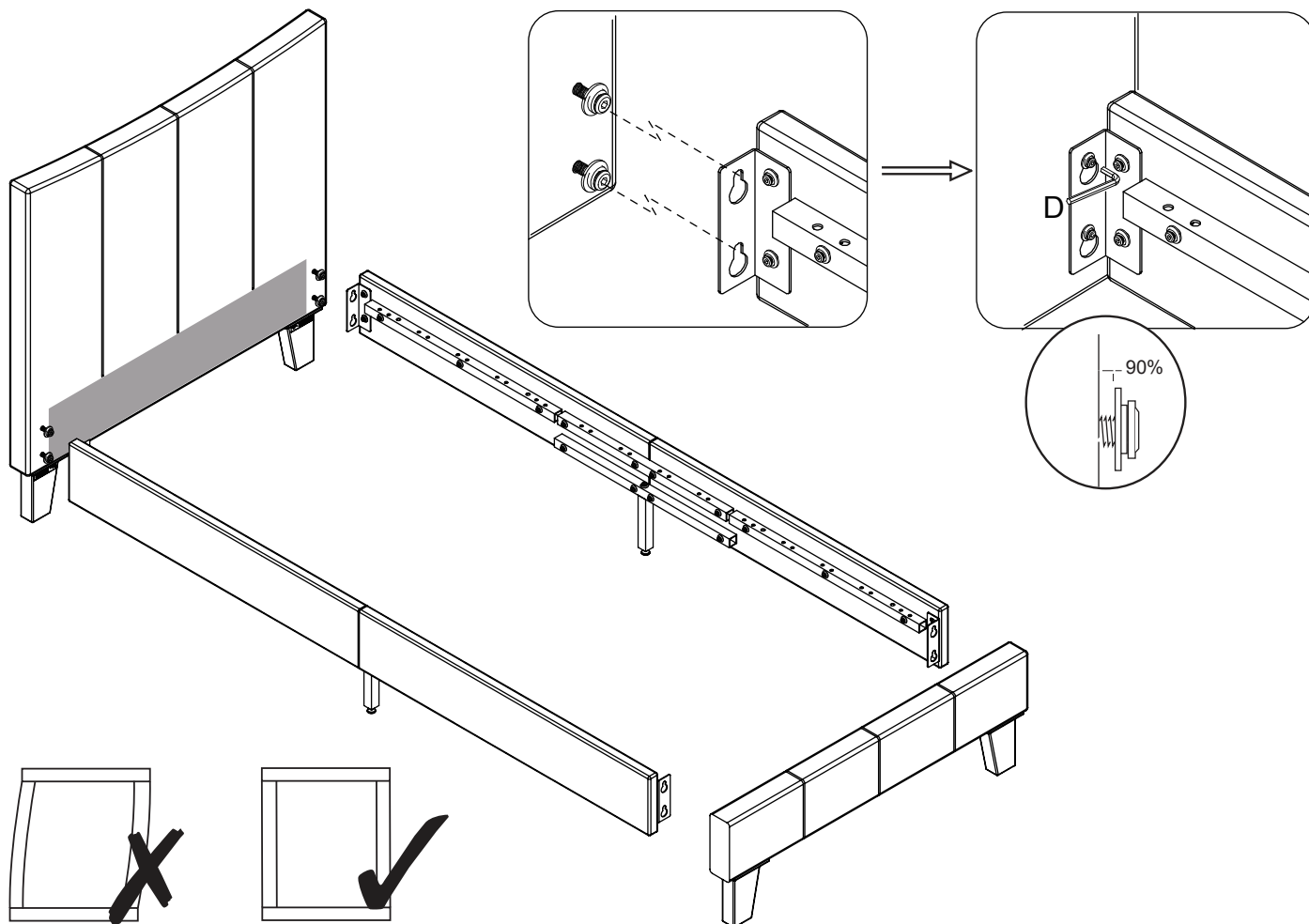

Make certain the bed is squared up as shown in the diagram then tighten all bed assembly bolts 100%.

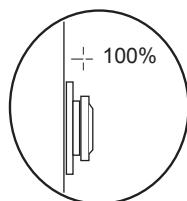



# Bed Assembly - Use Pack 'B'

Stage  
9a

**DOUBLE SIZE**

C  x12

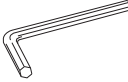
D  x1

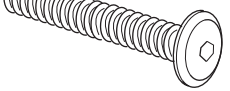
F  x6

G  x6

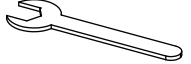
H  x1

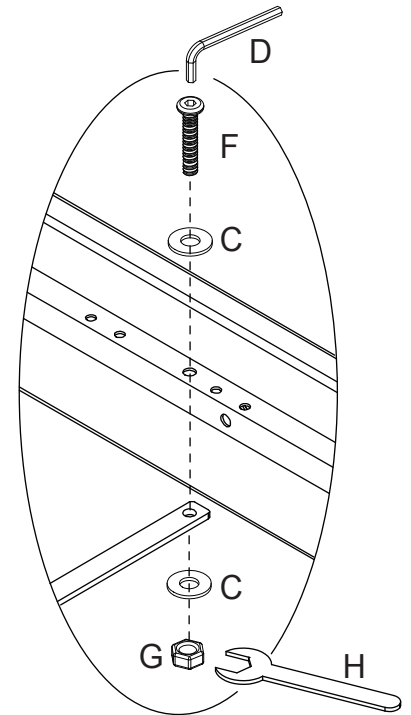
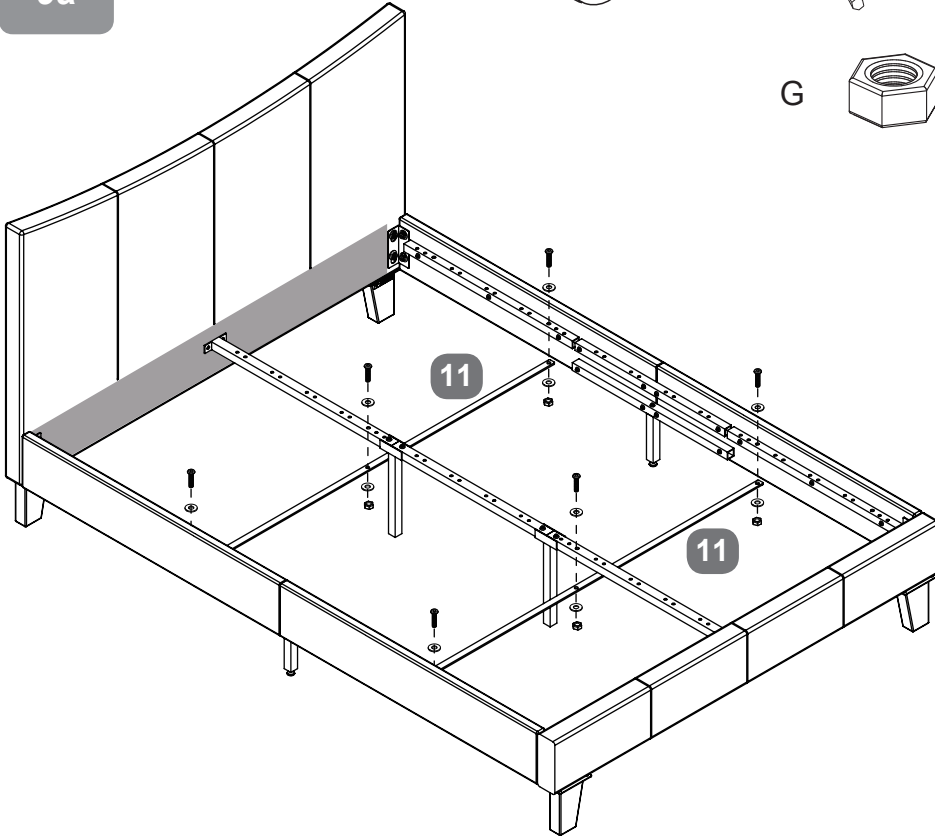



# Bed Assembly - Use Pack 'B'

Stage  
9b

**SINGLE SIZE**

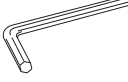
C  x8

D  x1

F  x4

G  x4

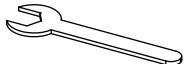
H  x1

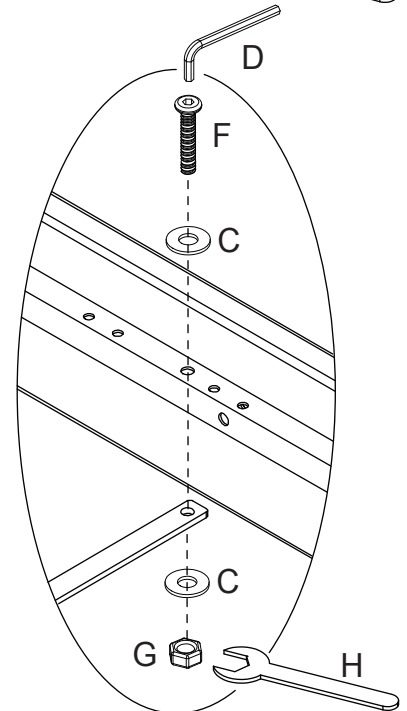
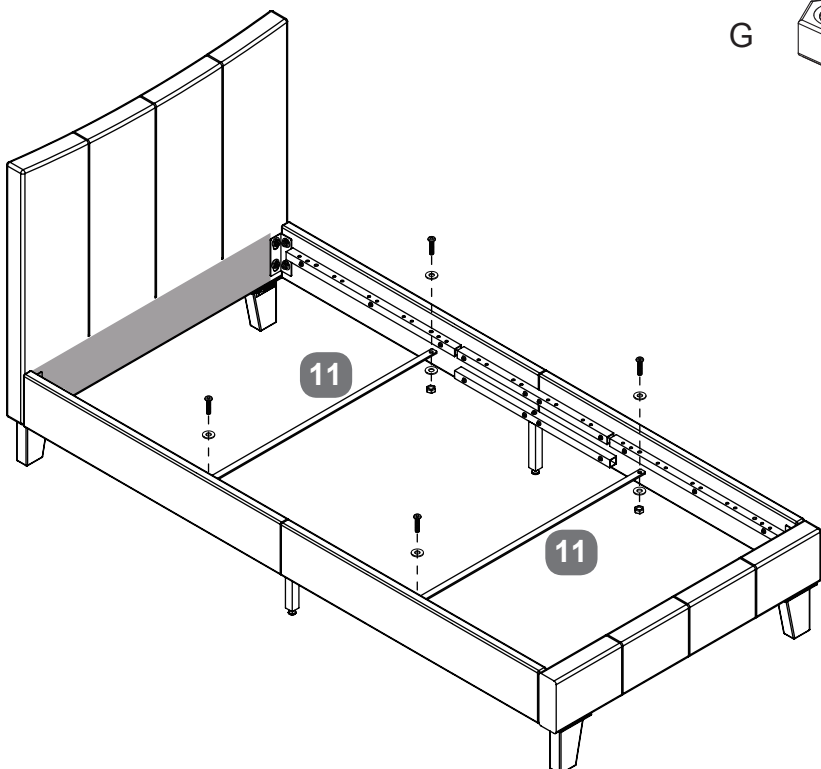

Stage  
10

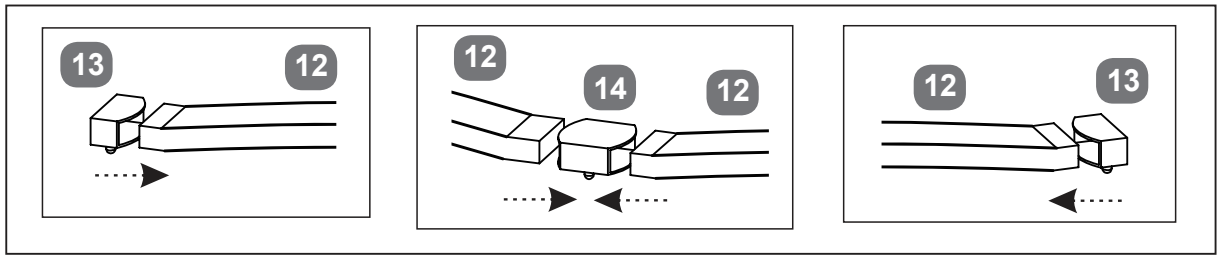

Fit slats (12) to double plastic cap (14). Fix single plastic caps (13) on each end. Connect set onto centre support bar (15&16) & metal support rails of side panels (3&4) - align the lugs & tap gently with a light hammer.

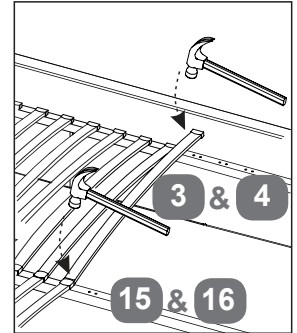
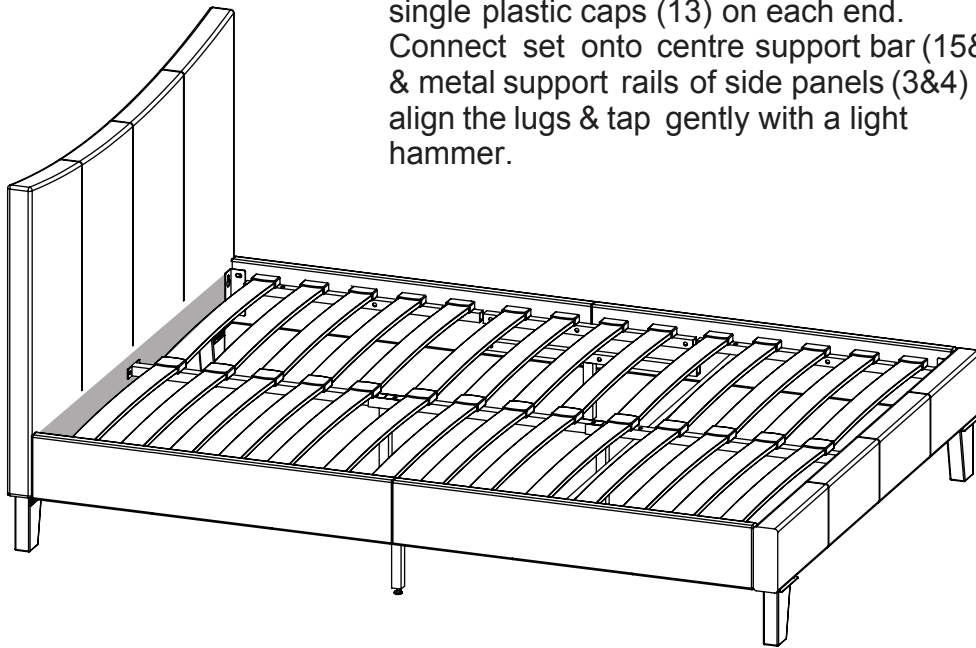

FOLLOW FOR SINGLE SIZE BEDSTEAD

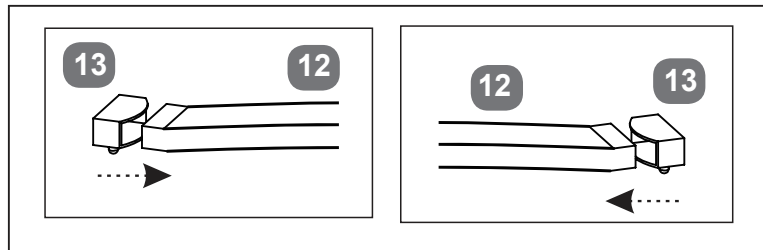

Fit slat (12) with single plastic caps (13) on each end. Connect set onto the metal support rails of both side panels (3&4) by aligning the lugs and tapping gently with a light hammer.

