

Grove Bed

OTTOMAN

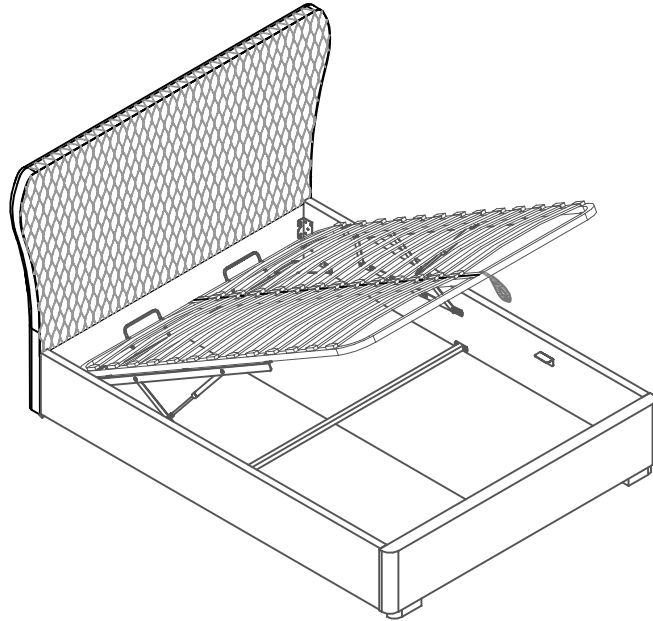

SLEEPMOTION

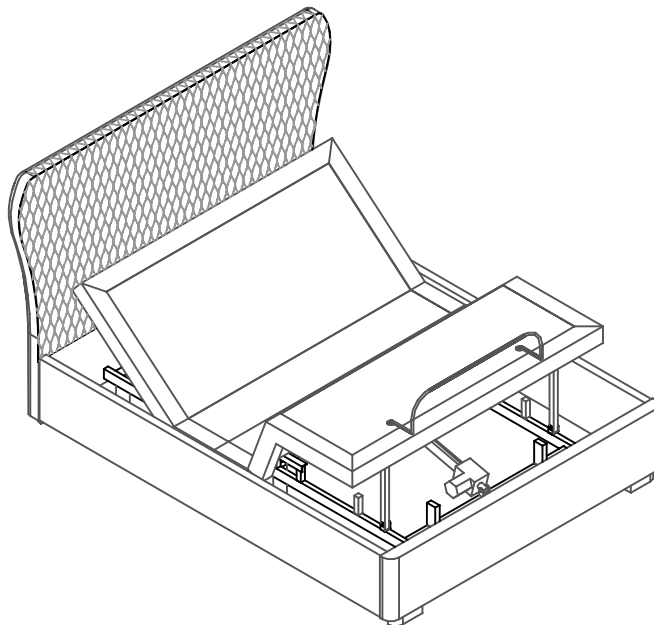

1 hour approx
assembly time



Two person
assembly

Dreams

HouseBeautiful

Thank you

Hello, thanks for choosing to purchase your bed from Dreams - you're now on your way to your best ever night's sleep. Before you begin building your bed, please take a moment to read through the instructions and make sure that you've got all the relevant parts listed on the following pages.



Assembly tips

Before you begin, it's best to identify all parts and fittings to build your bed. We advise laying these out on the floor to check you have everything, and familiarising yourself before building.



Top tip

We recommend that you build your new bed in the room you'd like it to be located - this will help prevent any risk of damage to your newly built bed whilst moving it.



Safety and care

It's really important to ensure children and animals are kept away from the assembly area, as there are small components used in this bed which could present a choking hazard. All plastic and wrapping materials should also be kept away from children and animals to prevent any risk of suffocation. To keep your little ones busy, there is a colouring page inside the back cover.



Help and support

At Dreams, it's our mission to give the whole nation a great night's sleep - this means that the quality of our products is of utmost importance to us. If there are any issues with your product or any missing parts, please visit our website at www.dreams.co.uk/help



Recycling

Please ensure that packaging is disposed of in a safe and environmentally friendly way, and recycle where possible. Our assembly instructions are printed on recycled paper. Please keep your assembly instructions safe to refer back to in the future.

Parts

Important information

Please identify which base you have purchased with your bed frame as the assembly method may change. Once you have identified you have all of the relevant parts and fittings, please follow the instructions for your chosen base below;

Ottoman: Page (5 - 11)

Sleepmotion: Page (12 -16)

OTTOMAN

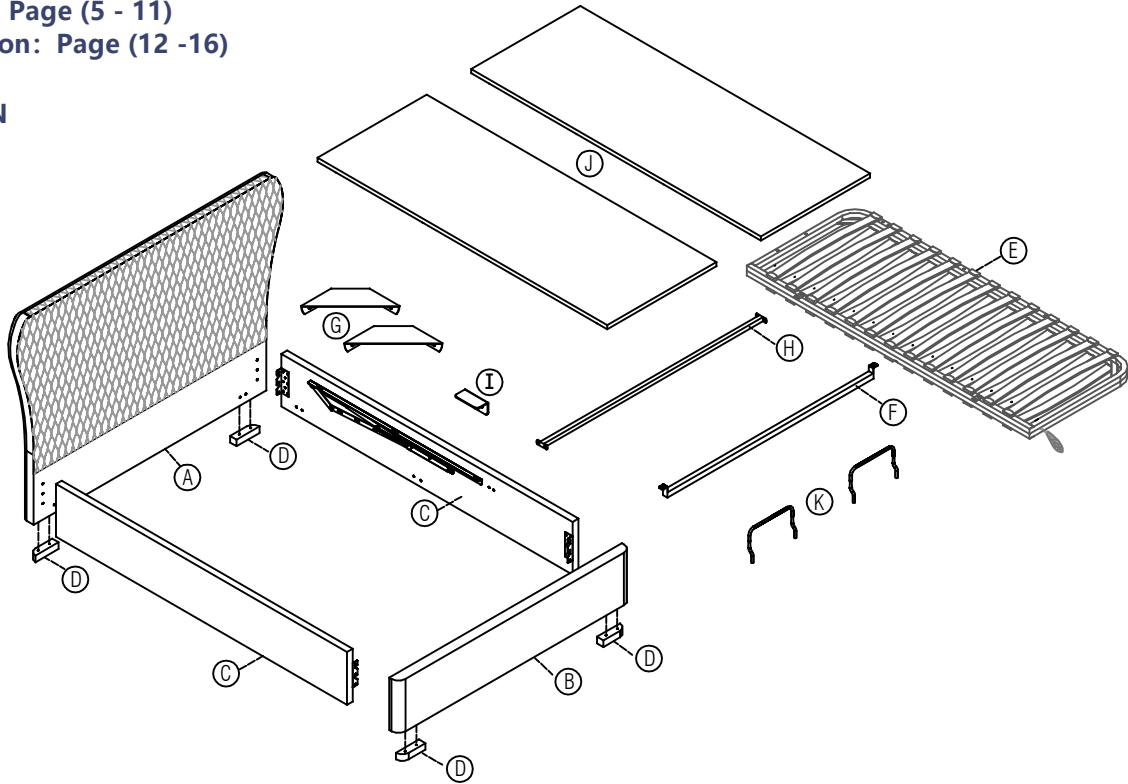

SLEEPMOTION

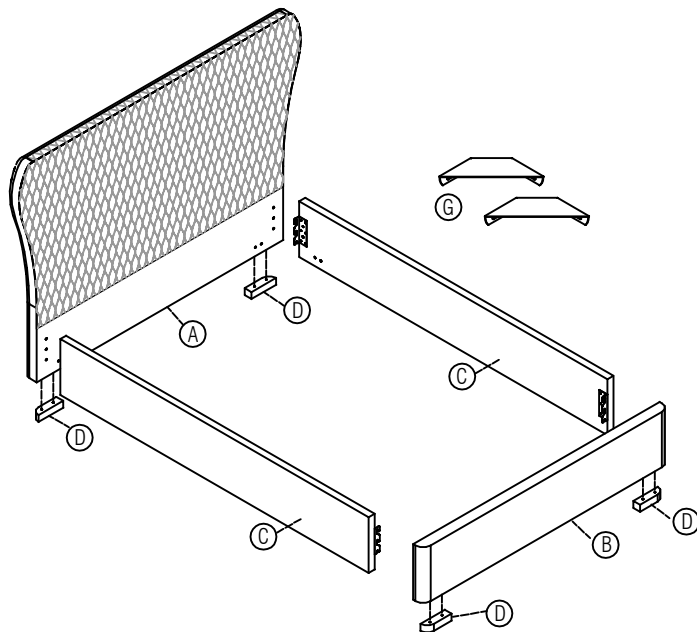





Parts list









Ref.	Description	Qty	Ref.	Description	Qty
A	Headboard	1	G	Angle Iron	2
B	Footboard	1	H	Metal Cross Rail	1
C	Side Panel - (Left & Right)	2	I	Metal Support	5
D	Foot of bed	4	J	Base Boards	2
E	Metal Slat Frame	1	K	Mattress Stoppers	2
F	Cross Bar	1			

Fittings

Please check you have all the parts listed below with your product;
HARDWARE FOR FITTING BED FRAME (Pack 'A')

- | | | |
|---------------------------------------------------------------------------------------------------------------------|--------------------------------------------------------------------------------------------------------------|----------------------------------------------------------------------------------------------------------------|
| 
1 Allen Key (for M8 bolt) x1pc | 
2 Bolts (M8x40mm) x8pcs | 
3 Bolts (M8x35mm) x20pcs |
| 
4 Spring Washers x20pcs | 
5 Flat Washers x20pcs | |

HARDWARE FOR FITTING METAL SLAT FRAME (Pack 'B')

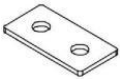
- | | | | |
|--------------------------------------------------------------------------------------------------------------|-----------------------------------------------------------------------------------------------------------------------------|------------------------------------------------------------------------------------------------------------------|----------------------------------------------------------------------------------------------------------------------------|
| 
2 Bolts (M8x50mm) x6pcs | 
3 Bolts (M8x35mm) x14pcs | 
4 Spring Washers x26pcs | 
5 Flat Washers x32pcs |
| 
6 Bolts (M8x20mm) x6pcs | 
7 Spanner (for M8 nut) x1pc | 
8 Wood screw M5 x 30x16pcs | 
9 Base board leg
Ø48 x 30 x16pcs |
| 
10 Nuts M8 x8pcs | 
11 Metal Plates for Slat Frame x2pcs | | |



Tools required

Please check you have all these below :



Scissors



Tape measure



Cross head
screwdriver

Ottoman assembly

Use pack 'A'

1

1  for M8 bolt x1pc

2  M8x40mm x8pcs

Bolts (M8x40mm) for Foot of bed(D)and to headboard & footboard (A & B)

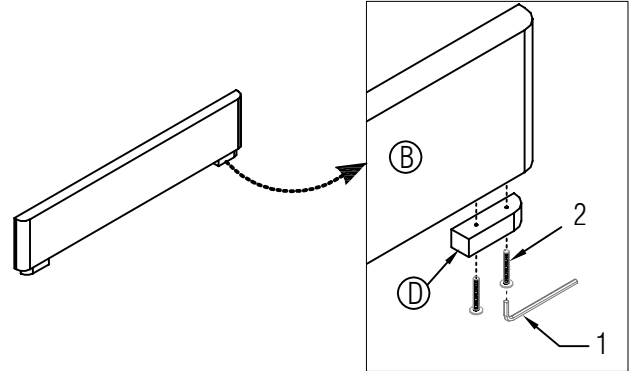
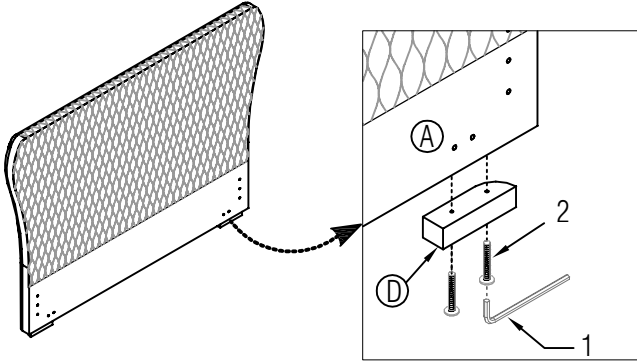

Use pack 'A'

2

1  for M8 bolt x1pc

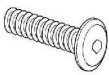
3  M8x35mm x12pcs

4  for M8 bolt x12pcs

5  for M8 bolt x12pcs

- i) Fit 2 sets of bolts (3), flat washers (5) to the holes in the headboard (A) as shown.
Note: Do not tighten fully but leave 10mm protruding as in the diagram.
Fit the side panels (C) to the headboard locating the brackets behind the flat washers.
Fit the other 1 sets of bolts through the brackets into the central pair of holes
.Loosely screw in the bolts but do not tighten them 100% yet.

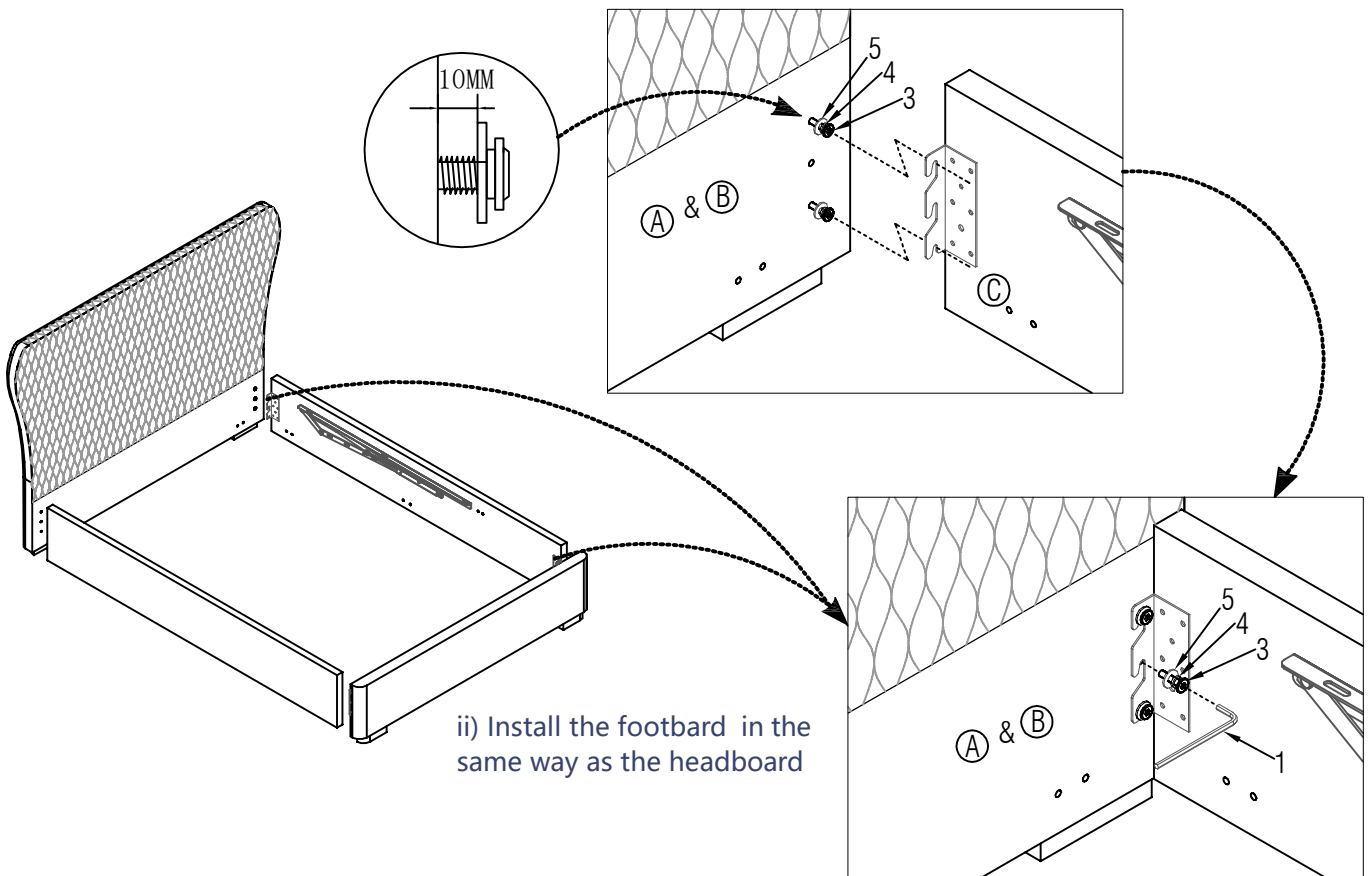

ii) Install the footboard in the same way as the headboard

Ottoman assembly

Use pack 'A'

3

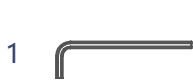

for M8 bolt x1pc



M8x35mm x8pcs



for M8 bolt x8pcs



for M8 bolt x8pcs

Fit the two angle brackets (G) loosely screwing the bolts(3), spring washers (4) & flat washers (5) into the threaded inserts in the corners of headboard (A) & the side rails (C).

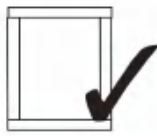
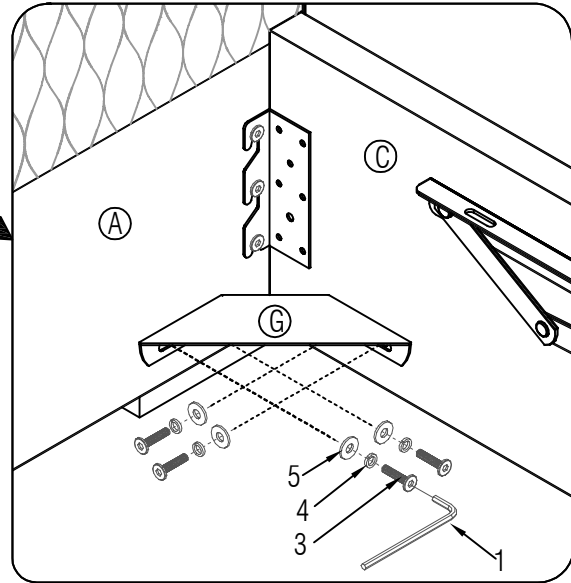
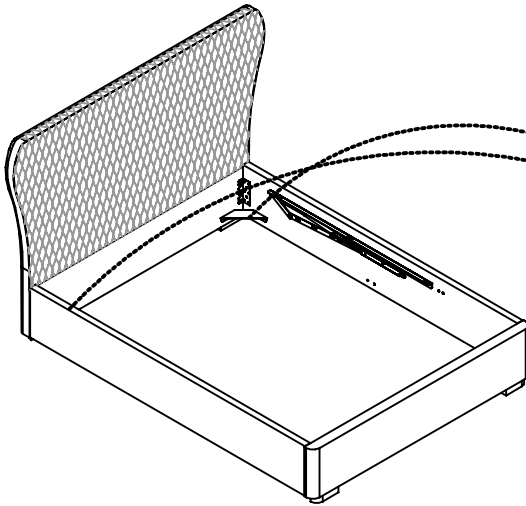

Make certain the bed is squared up as shown in the diagram then tighten all bed assembly bolts 100%.

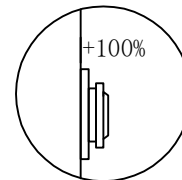

Use pack 'B'

4



M5 x 30 x16pcs



∅48 x 30 x16pcs

Base plate pushed into bed bottom

Cross-head Screwdrive in wood screw M5 x 30(8) for Base board leg(9) to Base board(J)

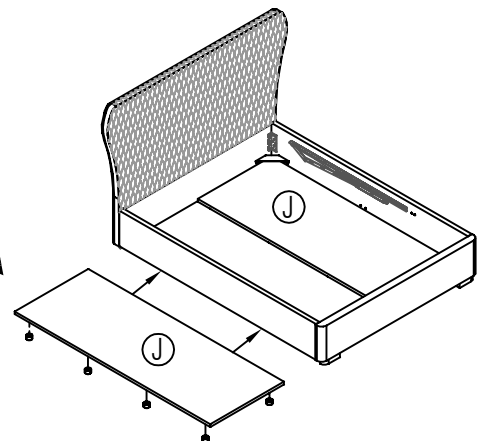
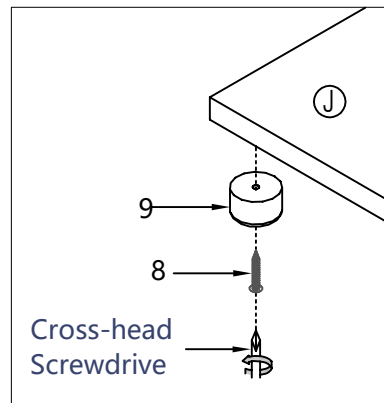

Ottoman assembly

Use pack 'B'

5

1  for M8 bolt x1pc

3  M8x35mm x14pcs

4  for M8 bolt x14pcs

5  for M8 bolt x14pcs

i) Fit the metal cross rail (H) loosely screwing the bolts(3), spring washers (4) & flat washers (5) into the threaded inserts in the side rails (D).

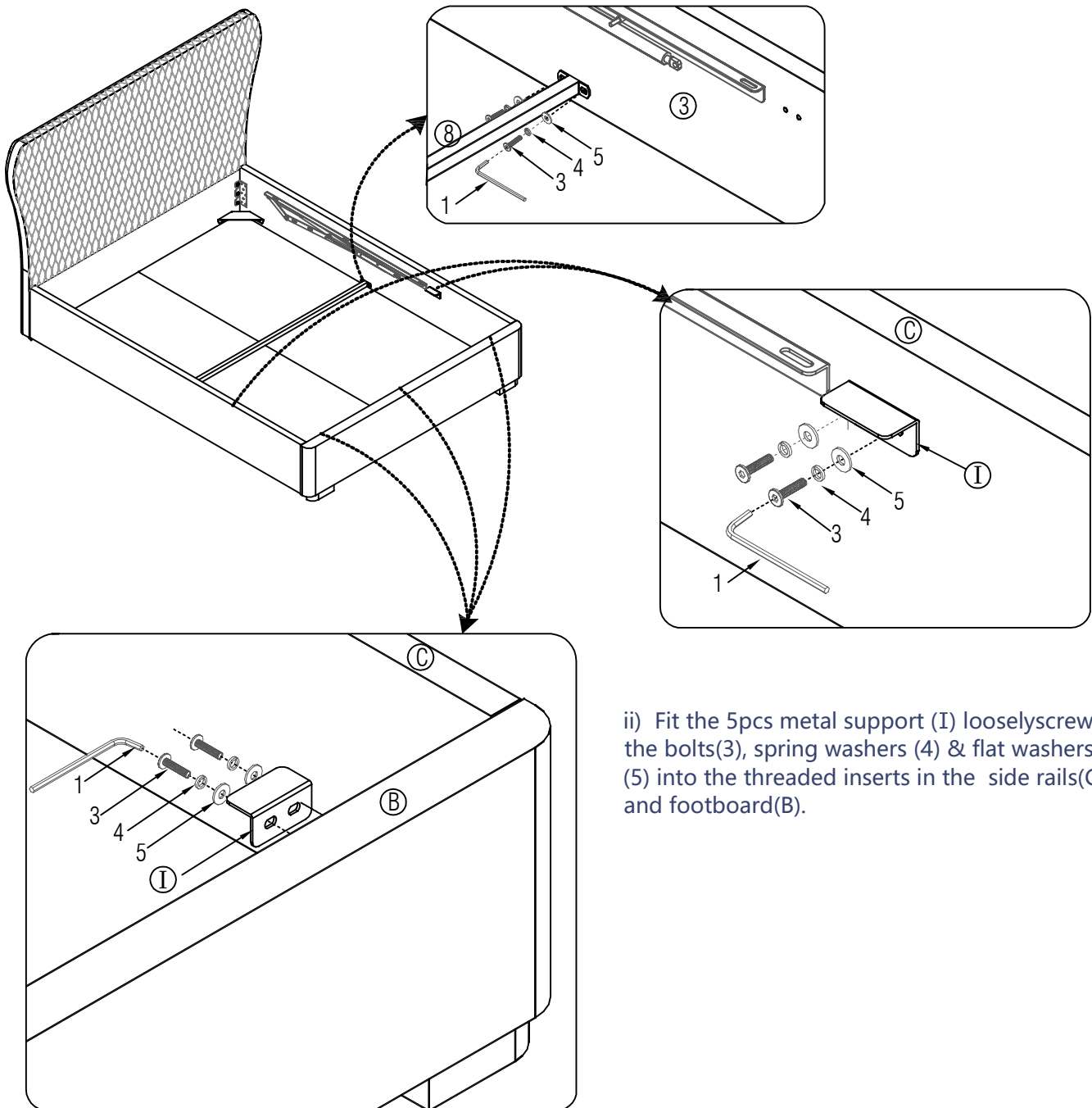

ii) Fit the 5pcs metal support (I) loosely screwing the bolts(3), spring washers (4) & flat washers (5) into the threaded inserts in the side rails(C) and footboard(B).

Ottoman assembly

Use pack 'B'

6



for M8 bolt x1pc

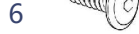

M8x20mm x6pcs



for M8 bolt x6pcs



for M8 bolt x6pcs



x2pcs

i) Fitting position for cross Bar (F) is clearly labeled. Pass bar through Metal Slat Frame (E) between first & second slats then carefully open the frame.

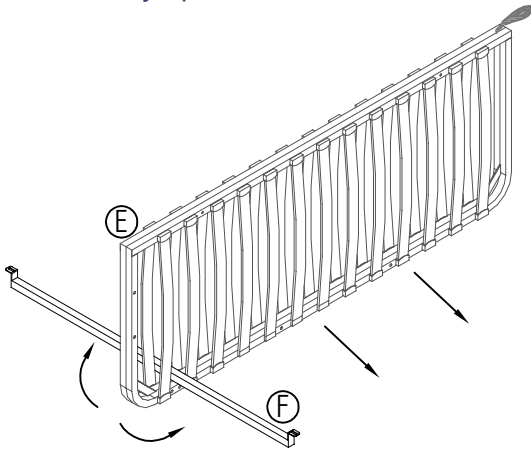

iii) Using four sets of bolts (6) , spring washer (4) & flat washers (5) fit two pieces of the metal plate (11) into threaded inserts on top of the frame. Using Allen key (4), tighten all six bolts 100%.

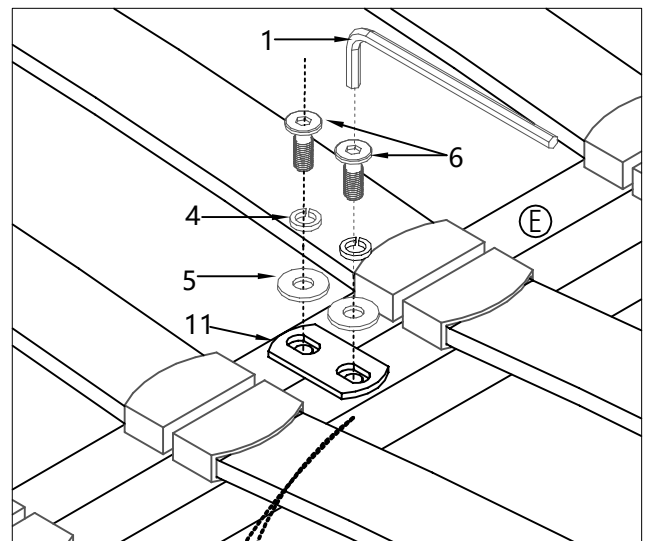



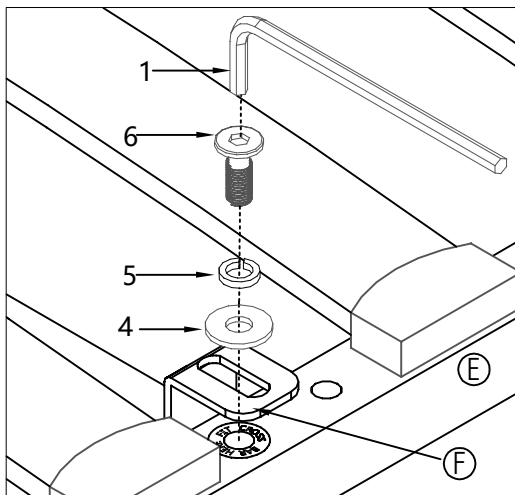



ii) Ease the plates on top of the cross bar (F) onto top of the slat frame sides and loosely fit two sets of bolts(6), spring washers (4) & flat washers (5). Screw them through the plates into the threaded inserts. Do not tighten yet.



Ottoman assembly

Use pack 'B'

- 7  1 for M8 bolt x1pc
- 2  M8x50mm x6pcs
- 3  for M8 bolt x6pcs
- 4  for M8 bolt x12pcs
- 7  for M8 bolt x1pc
- 10  for M8 bolt x6pcs

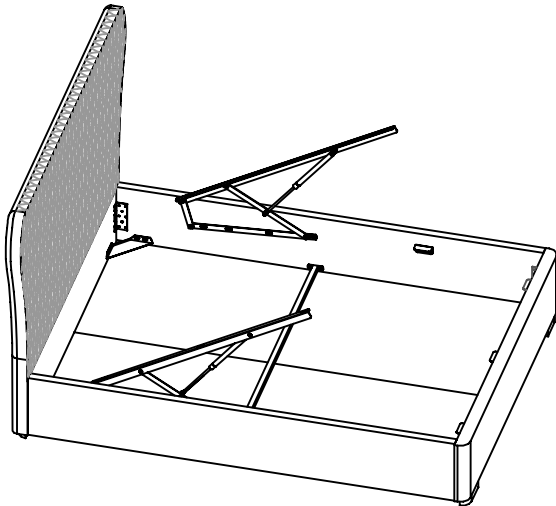

- i) Un-tie each mechanism & take out the transit protection block

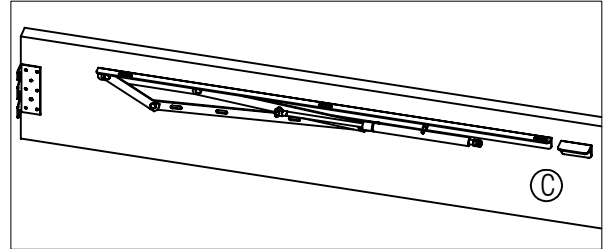

- ii) Tilt the arms upwards

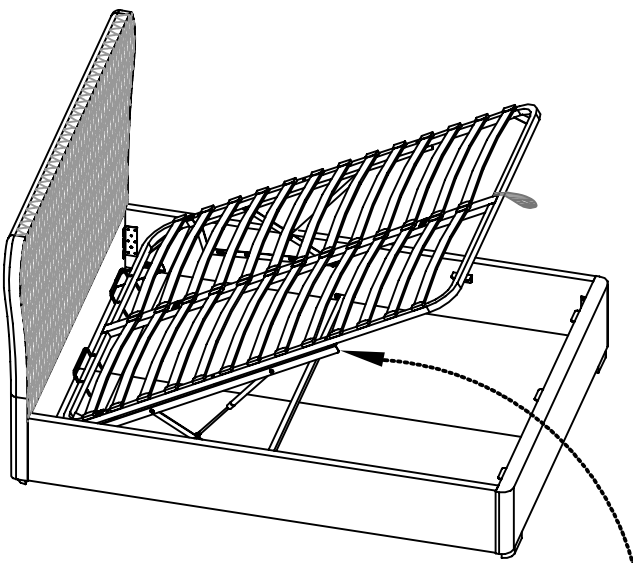
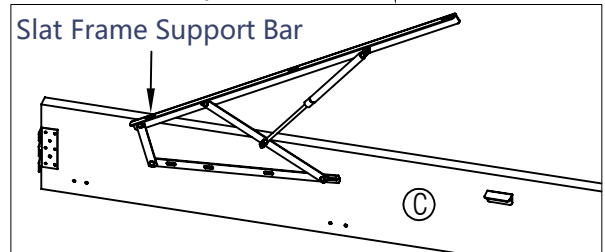

- iii) With help from your assistant, lift slat frame (E) onto slat frame support bars aligning first set of holes on slat frame with first set of holes in support bars (nearest to headboard).

- iv) Using three bolt sets on each side (2), (5), (4) & (10), fix slat frame to the support bars but do not tighten fully.

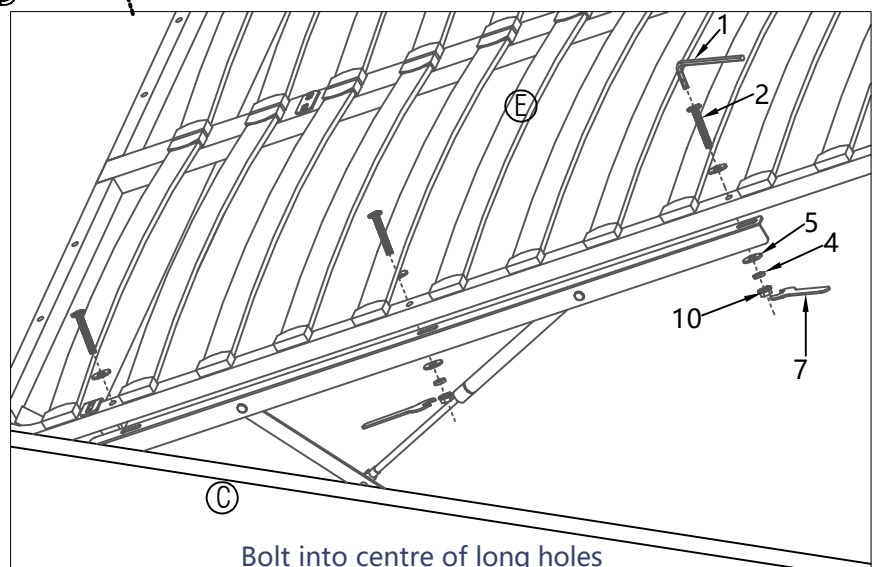

Bolt into centre of long holes

Ottoman assembly

Use pack 'B'

8

1 
for M8 bolt x1pc

7 
for M8 bolt x1pc

Carefully lay frame down making sure there is an even gap all round as in the sketch.

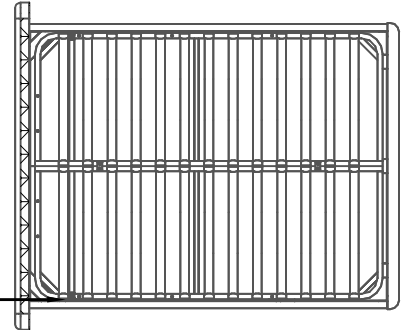
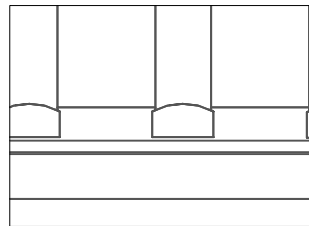
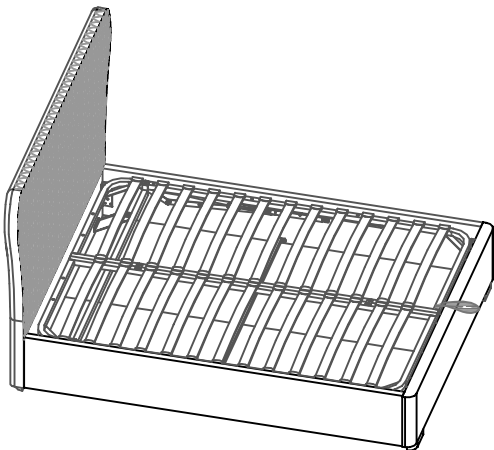

Hold frame securely then tighten all six bolt sets 100% using spanner(7) & Allen key (1).

Use pack 'B'

9

7 
for M8 bolt x1pc

10 
for M8 bolt x2pcs

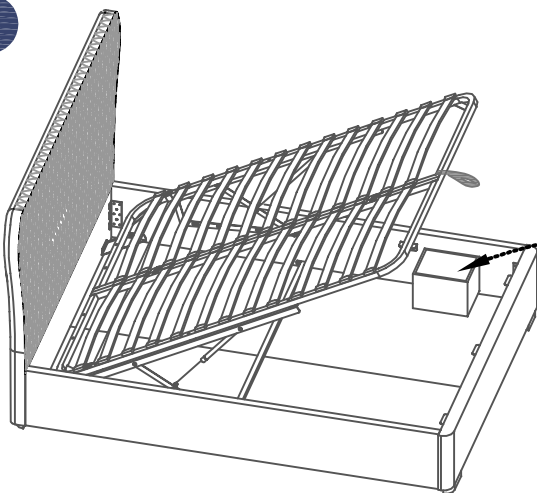

Note: Be very careful what you store under the bed -the top of an item, like a suitcase or a box must not touch the slats or they may be damaged. Maximum storage height is 240mm.

During this next step, the assistant should hold up the slat frame.

On side panels (C) slide gas-lift piston stems (X) onto the axles (Y) then fit the flange lock-nuts (10).

Tighten nuts with spanner (7) . BUT DO NOT over-tighten. A small gap is left so stems can move freely - this is important - see sketch below.

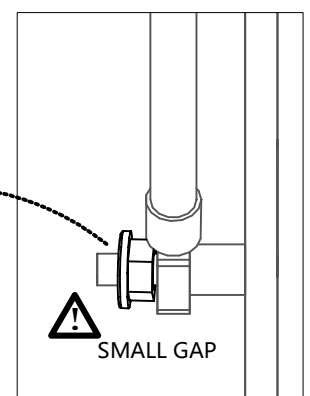
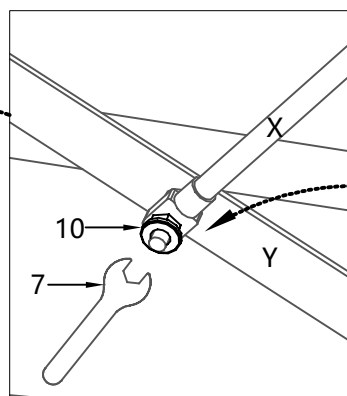
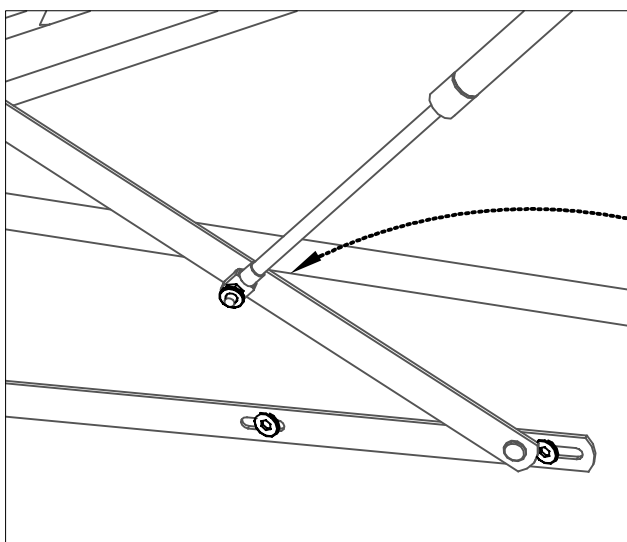

Ottoman assembly

Use pack 'B'

10

Push x2 Mattress Stoppers (K) into metal frame, they should go all the way through the upper & lower metal sections.

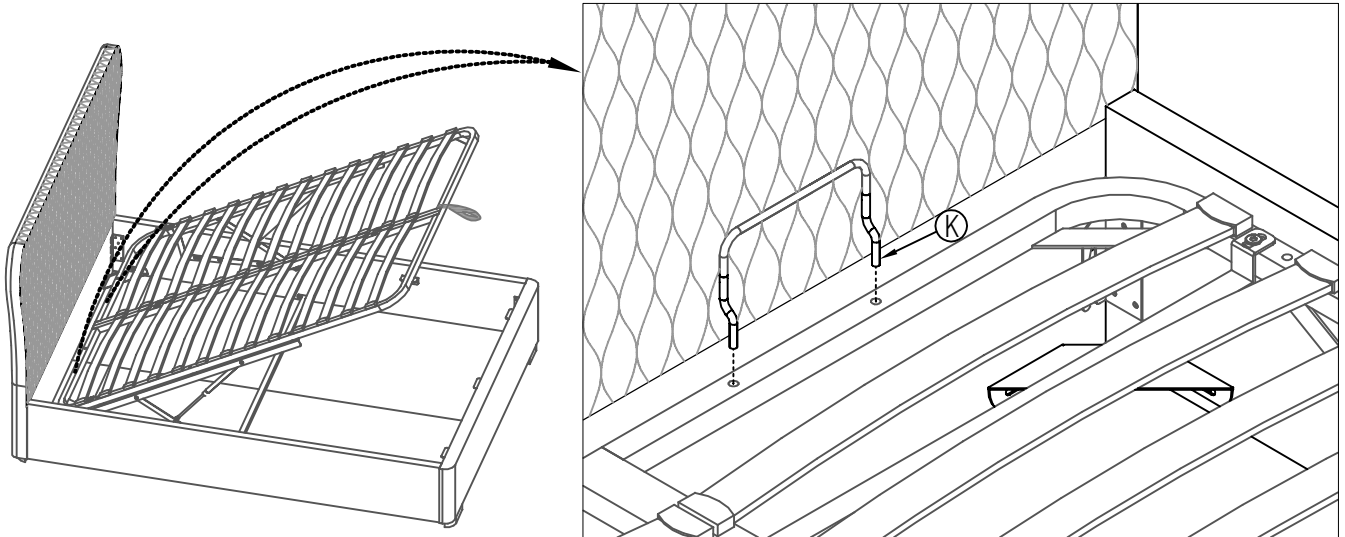

NOTE: Before moving the slat frame, place the mattress on the slats. Without a mattress in place, the speed of movement is quick and may cause injury. Carefully lower the frame with the hand-strap ensuring the frame sides are aligned with the side panels; there should be an even gap on each side. If not aligned, check bed is still square (see Step 2) and if it is, but gaps are still not even, re-align as in Step 8.

Depending on the weight of the mattress, the rising speed will vary so be careful until you get used to the speed. Always use the strap to lift or lower the frame - keep fingers well away from the moving parts.

When fully assembled and the mattress in position, please raise & lower the ottoman 4/5 times to ensure the gas pistons are fully lubricated.

Sleepmotion assembly

Please ensure you have built your sleepmotion base first (please refer to instructions in your sleepmotion box to build the base). Please construct your sleep motion with the 15cm leg and then follow the below instructions to build the bed frame.

- 1 Screw in the Legs and put Bed Base in the Position in which it will be used

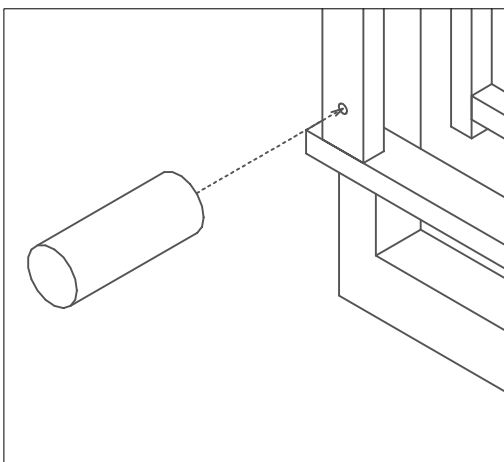
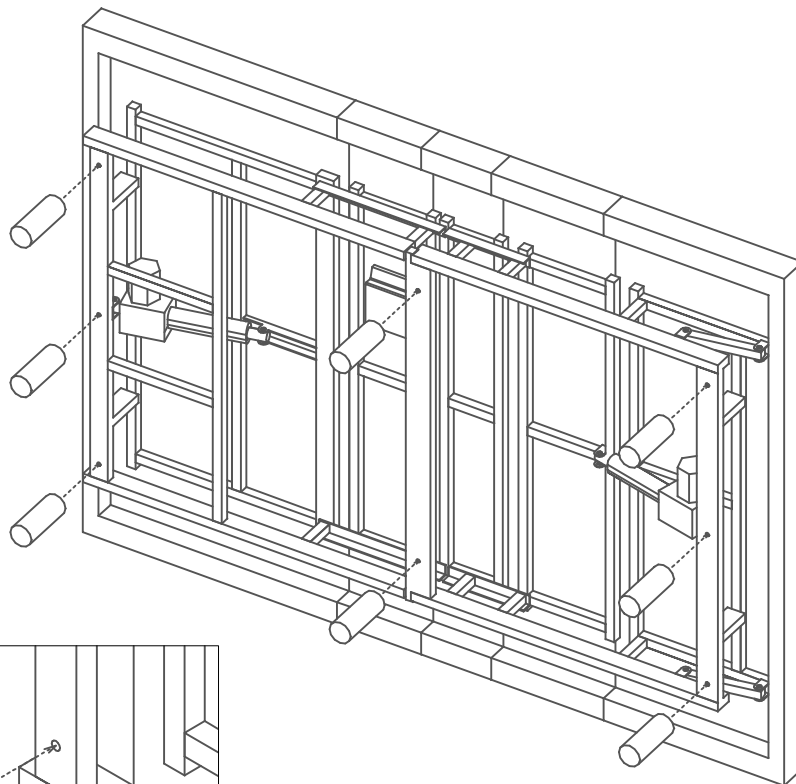

Sleepmotion assembly

Use pack 'A'

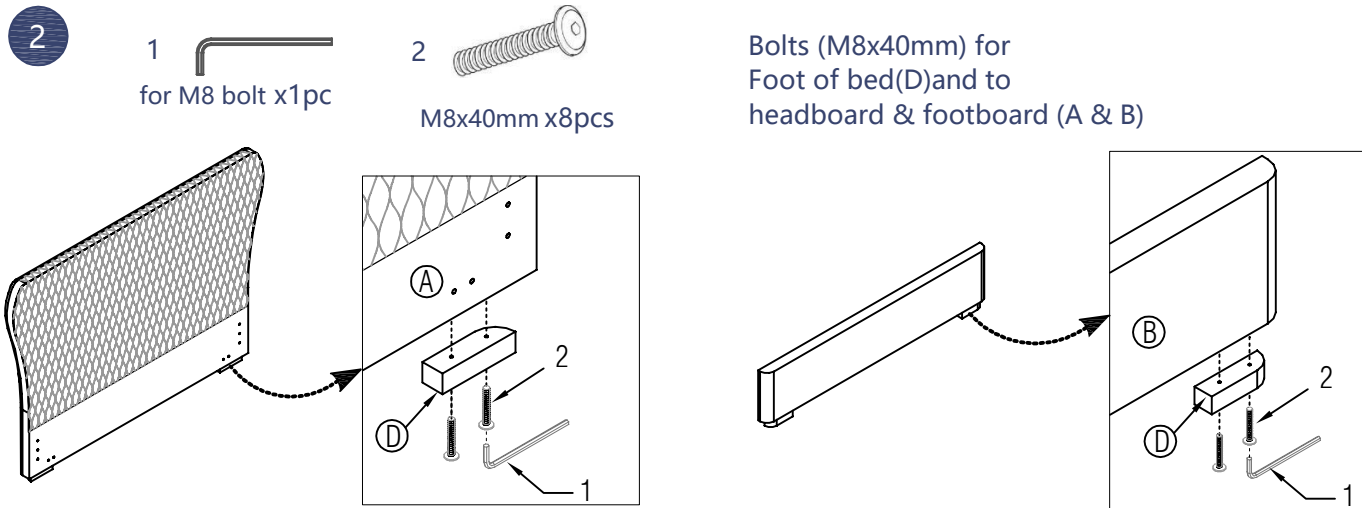

Use pack 'A'



Fit 2 sets of bolts (3), flat washers (5) to the holes in the headboard (A) as shown.

Note: Do not tighten fully but leave 10mm protruding as in the diagram.

Fit the side panels (C) to the headboard locating the brackets behind the flat washers.

Fit the other 1 sets of bolts through the brackets into the central pair of holes

.Loosely screw in the bolts but do not tighten them 100% yet.

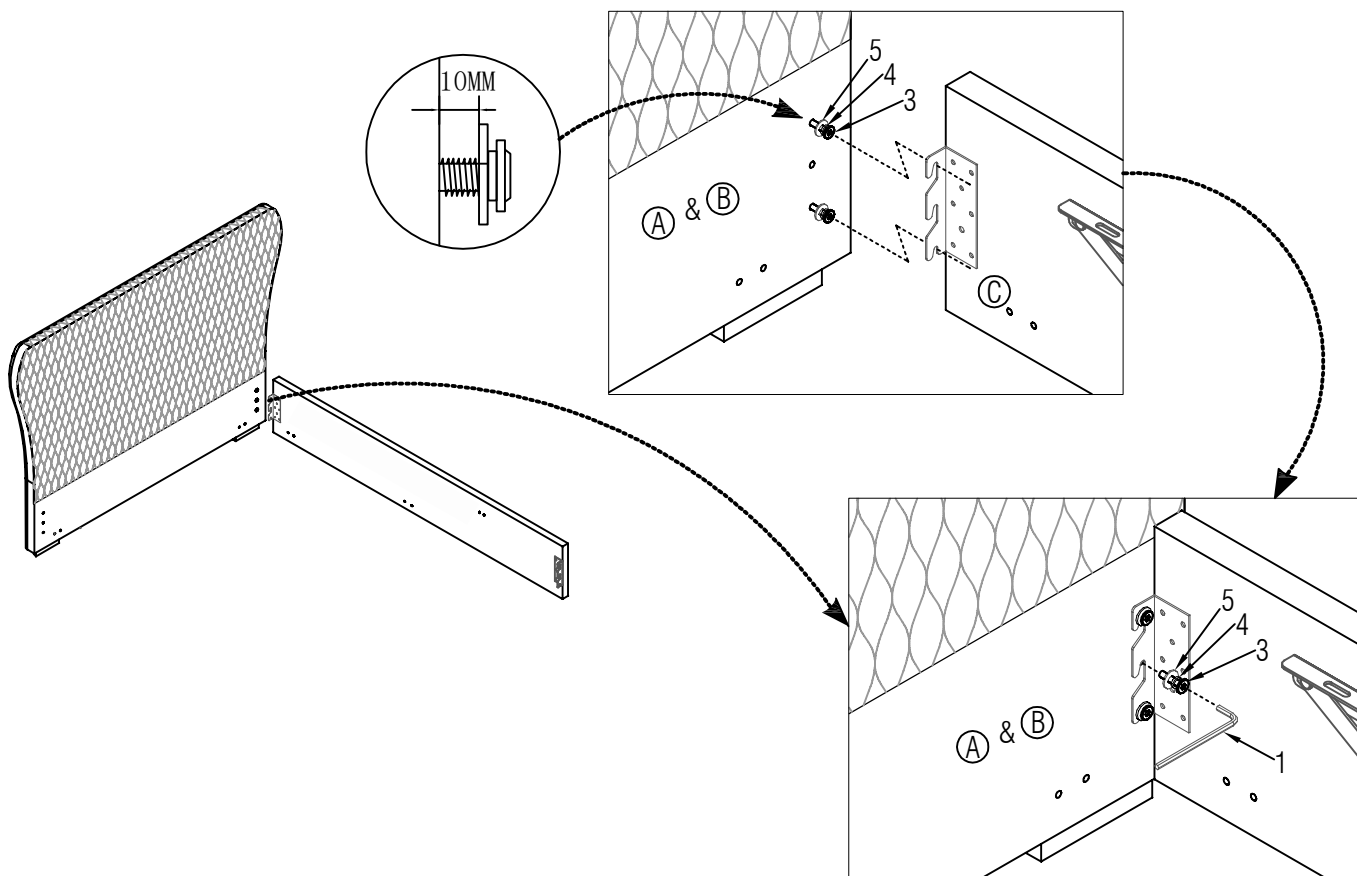

Sleepmotion assembly

4

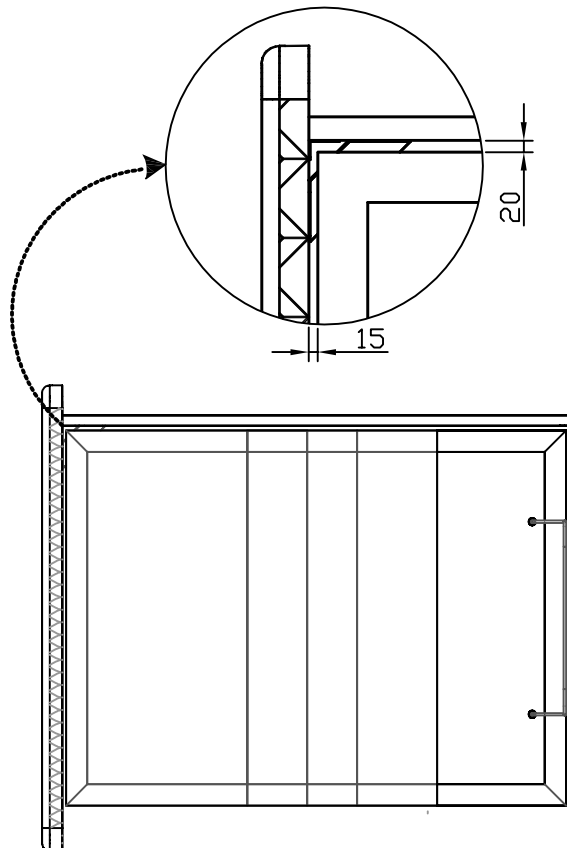
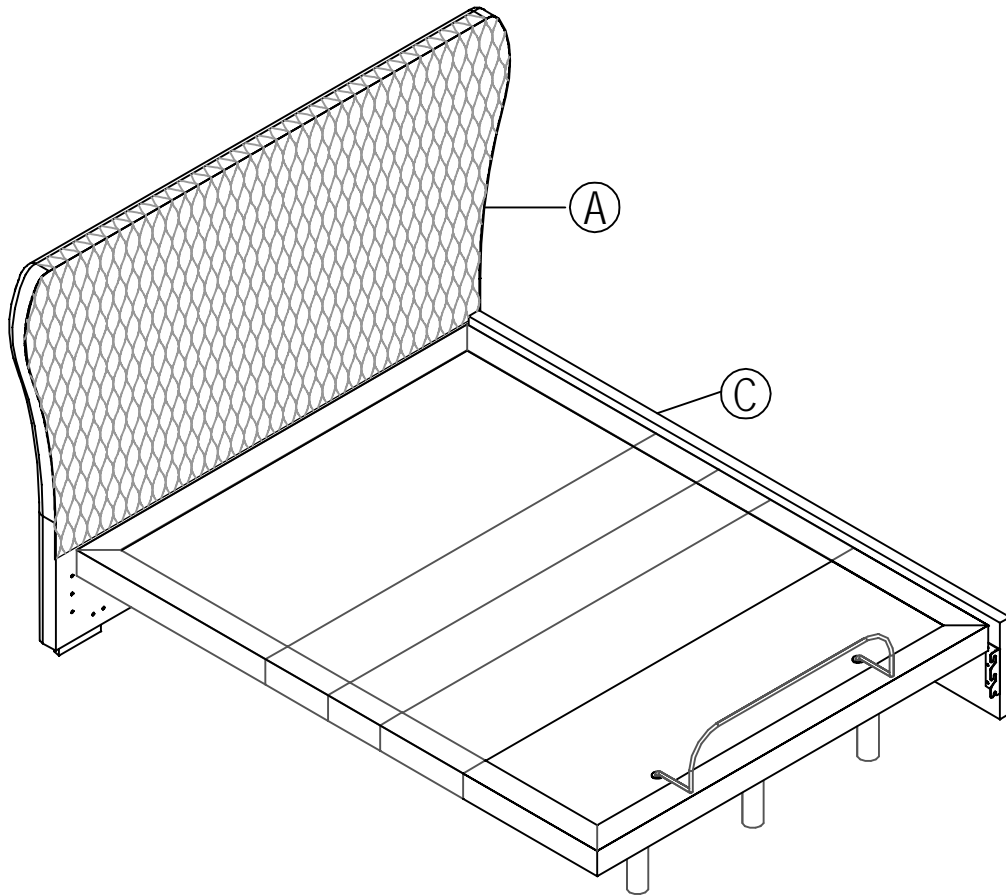

Sleepmotion assembly

5 Raise the Head and Foot Ends of the Bed Base

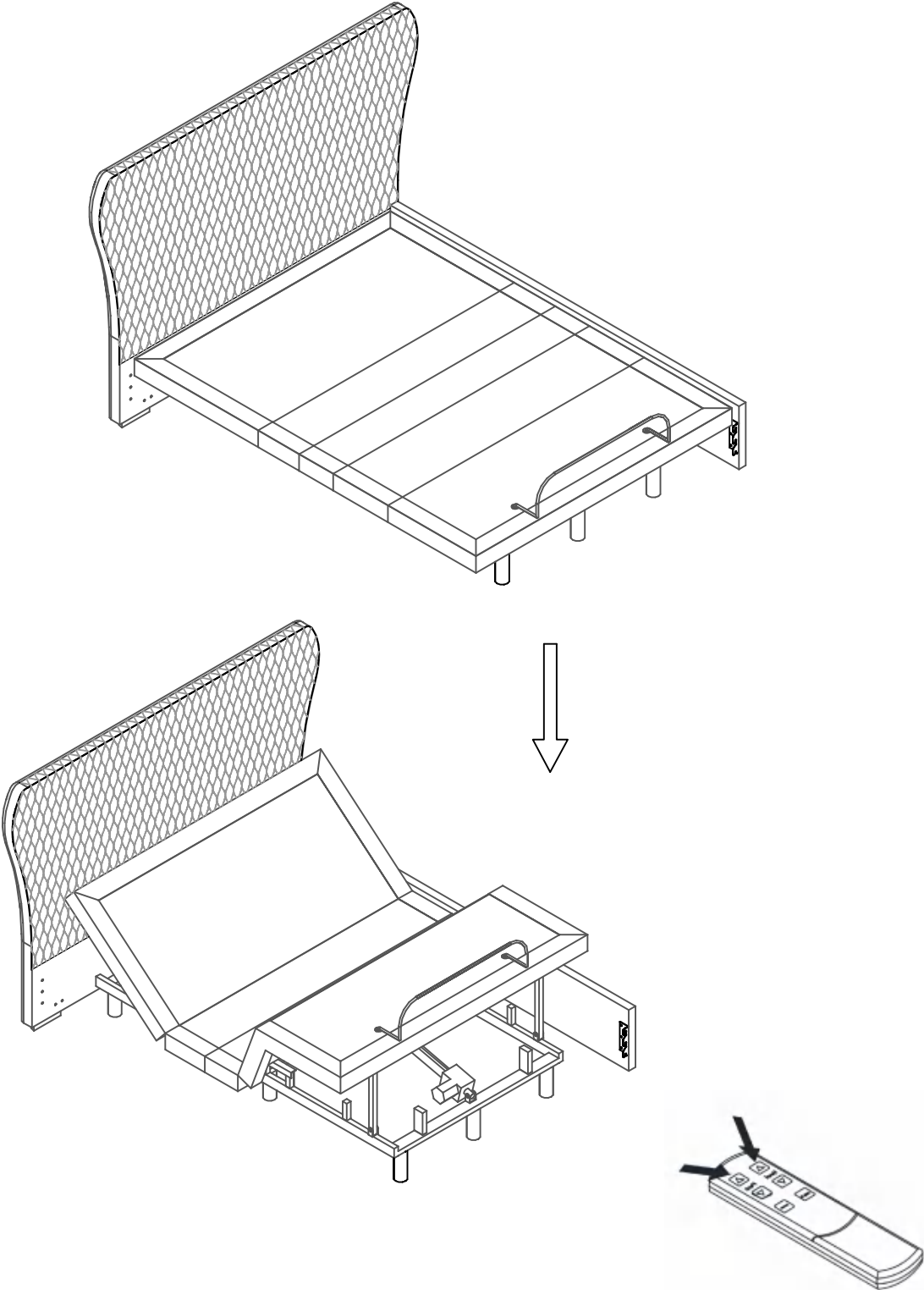

Sleepmotion assembly

Use pack 'A'

6

1



for M8 bolt x1pc

3



M8x35mm x9pcs

4



for M8 bolt x9pcs

5



for M8 bolt x9pcs

- i) Position Foot End and connect SideRail brackets.
- ii) Make sure everything is working properly then fit second side rail
- iii) Install the footboard in the same way as the headboard

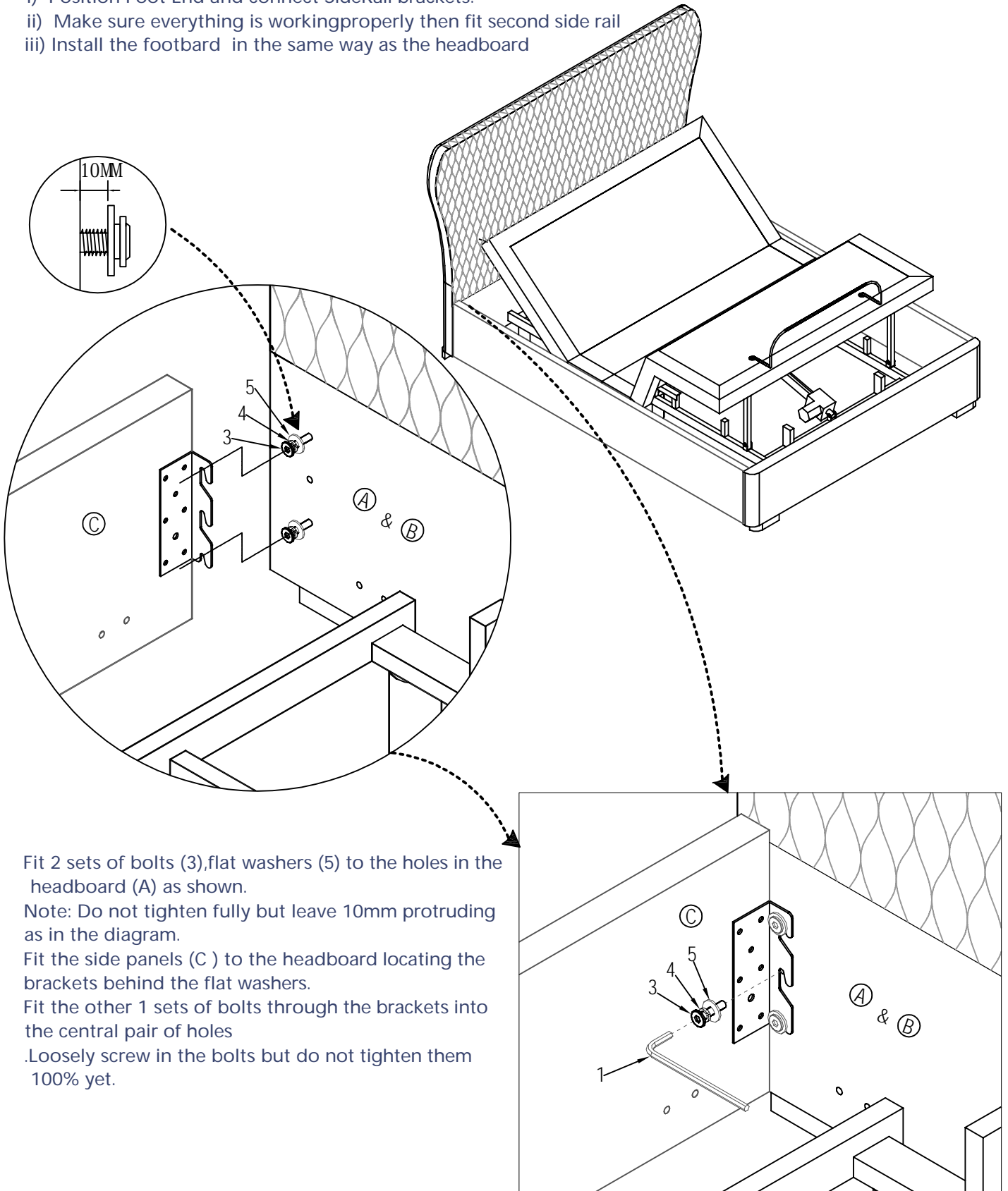

Fit 2 sets of bolts (3), flat washers (5) to the holes in the headboard (A) as shown.

Note: Do not tighten fully but leave 10mm protruding as in the diagram.

Fit the side panels (C) to the headboard locating the brackets behind the flat washers.

Fit the other 1 sets of bolts through the brackets into the central pair of holes

Loosely screw in the bolts but do not tighten them 100% yet.

Sleepmotion assembly

7

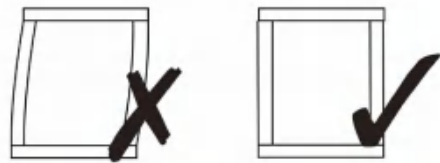
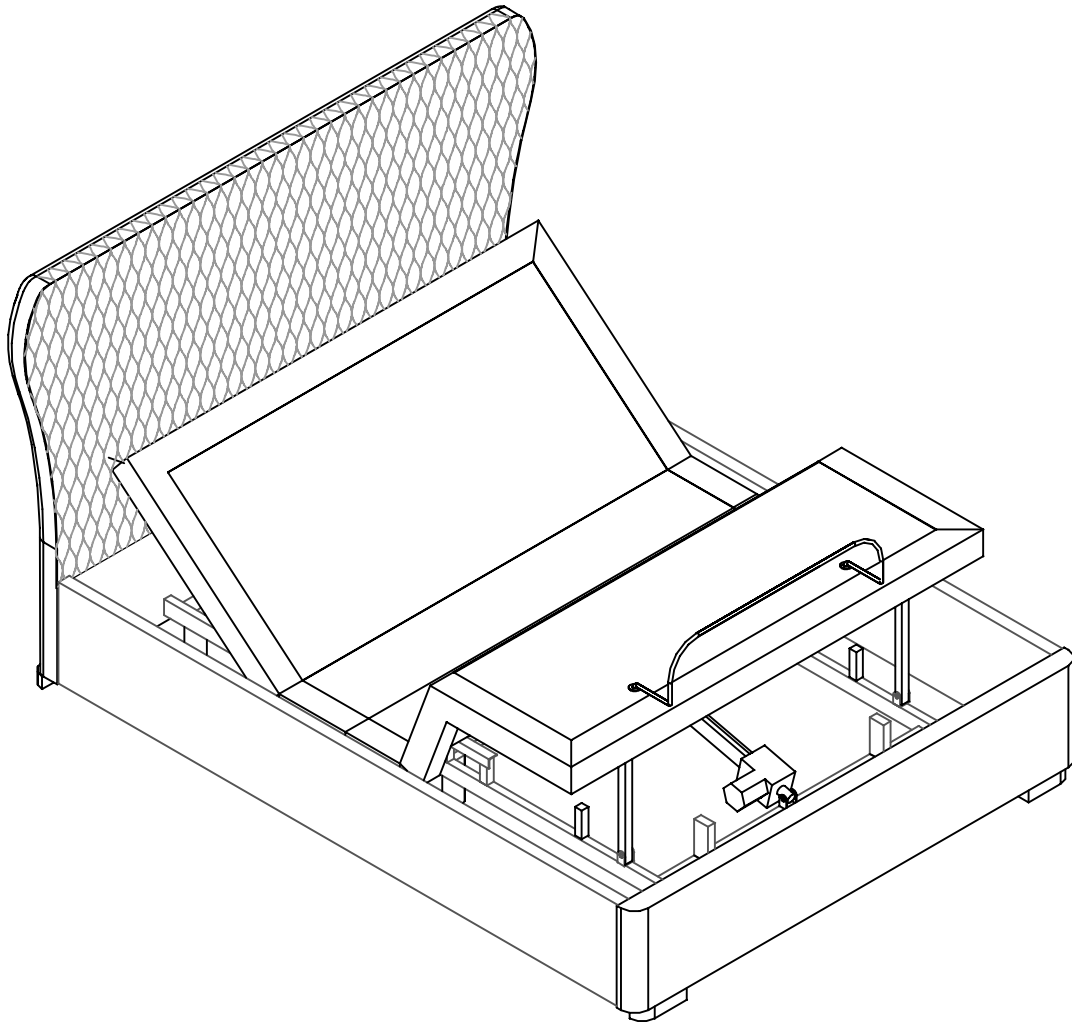

Make certain the bed is squared up as shown in the diagram then tighten all bed assembly bolts 100%.

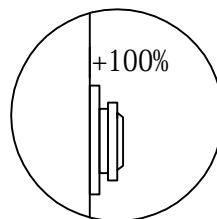

Care and maintenance

Here are some tips to keep your new bed in tip-top condition



Cleaning

To clean your new bed, we'd advise using a warm damp cloth - please do not use abrasive chemicals or bleach as this may damage the product.



Checking and moving

Periodically we recommend you check that the screws or fixtures haven't become loose, over time. To move your new bed, we recommend lifting it where possible, as dragging or pushing it could cause damage to your flooring.



Wood

Please note each of our wooden pieces are unique, meaning that markings and shade can vary slightly between beds. Over a period of time, the wood might lighten or fade slightly due to light exposure.



Fabric

Please note depending on the lighting, positioning and surroundings of your room, the shade of the colour can sometimes appear slightly different. Over a period of time, the colour might lighten or fade slightly due to light exposure.



Metal

Metal tends to be more resilient to everyday wear and tear. We recommend to gently dust your metal furniture and keep it dry to maintain its look.

Thank you for shopping with us - we hope you have a great night's sleep

Sleep well



Little dreamers

Keep the little ones entertained while you assemble your new purchase.

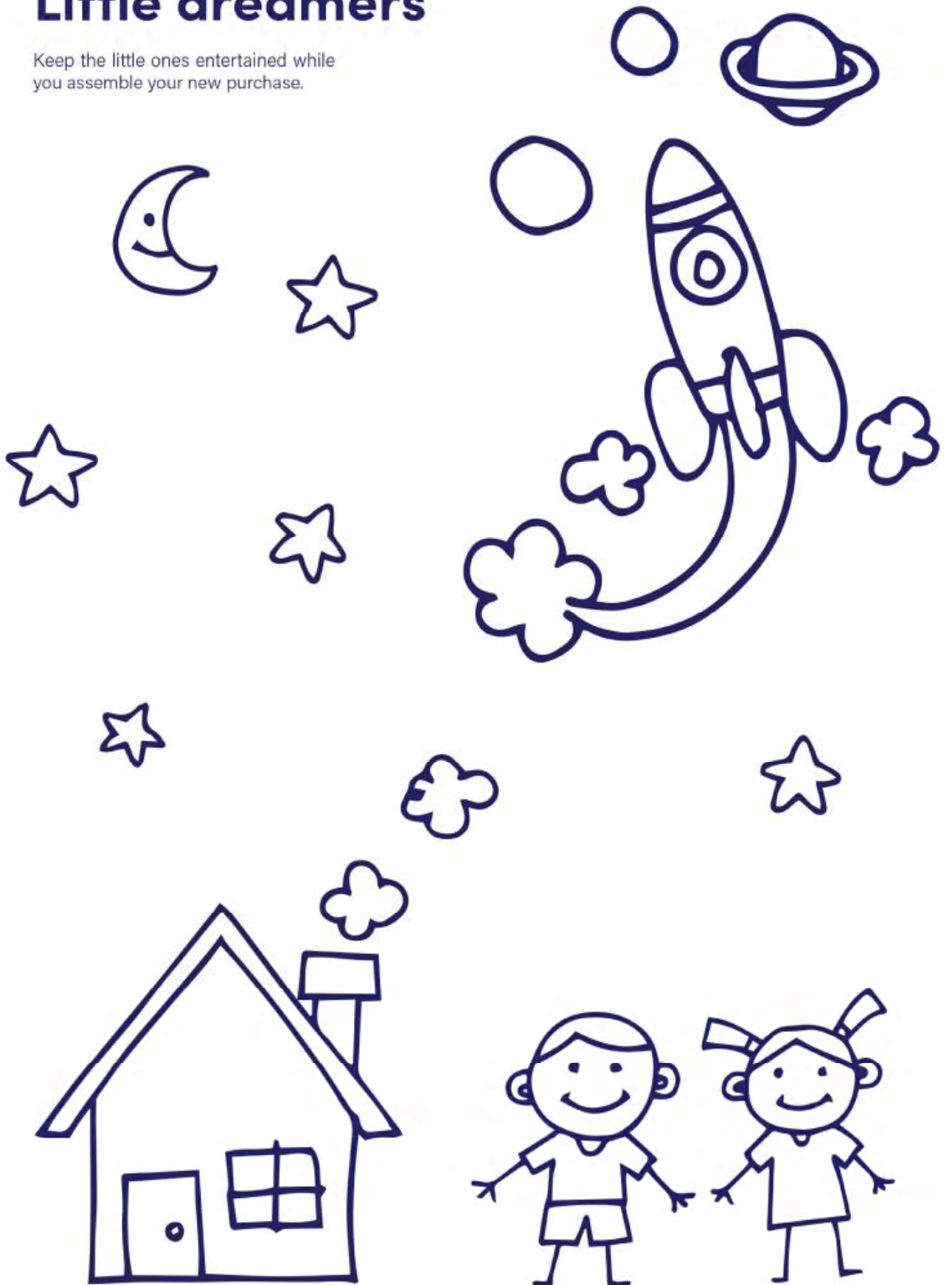

Dreams
HouseBeautiful