

200i Headboard

Assembly Instructions



Need assistance?

Call: 0344 292 0000



Helpful advise before you begin:

1. We suggest you spend a short time reading through this leaflet and then follow the simple step by step instructions.
2. If you follow the instructions carefully the end result should be worth the effort.
3. Do not discard any of the packaging until you have checked that you have all the parts and the pack of fittings.
4. Assemble this product on a carpet.
5. To ensure an easier assembly, we strongly advise that all fittings are only finger tightened during initial assembly. Only upon completion of the assembly should all fixing points be fully tightened.
6. We recommend a periodic check on all fixing points to make sure they remain fully tightened.
7. Keep glue and fittings out of children's reach.
8. Do not use any other tools other than those recommended to build this product.
9. Please do not use substitute parts. Use only additional or replacement parts supplied by Dreams Ltd.
10. In the unlikely event that this product has missing or damaged parts, please call 0344 292 0000 to obtain spares.



2 x people recommended to assemble this product



Approximate time to assemble this product



Retain these instructions for future reference





Do not discard any of the packaging until you have checked that you have all the parts and the pack of fixings.

Parks checklist

01 Headboard

01					

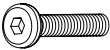
Fittings Checklist

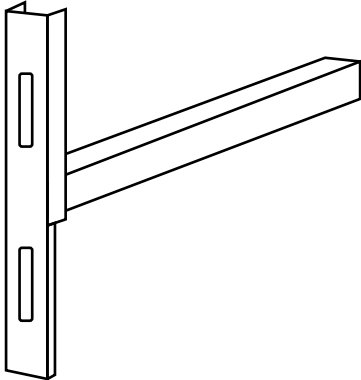
	Bolts x 8
	Allen key x 1
	Headboard bracket x 2

Headboard Assembly

Step 1:

Open box and remove headboard

Picture A

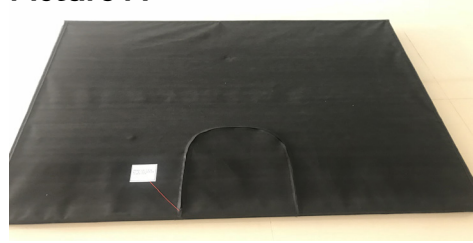

Step 2:

Un-zip the back of headboard and remove the box.

Picture B



Step 3:

Remove components and check parts

2 x Headboard Bracket

8 x Bolts

1 x Allen key

Picture C

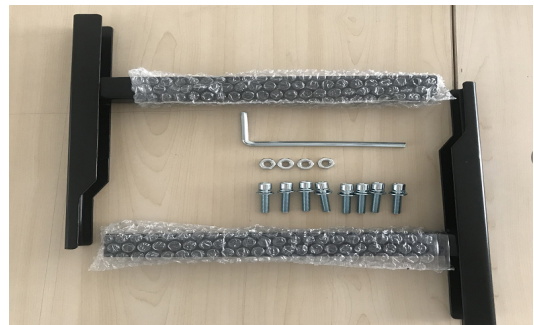

Step 4:

Fix the headboard brackets to the base,
you will need:

4 x Bolts

Picture D



Step 5:

Fix the headboard to the headboard brackets,
you will need:

4 x Bolts

Picture E



Care of your Dreams Furniture

Your new bed from Dreams is more than a beautiful piece of furniture. It's an investment in your health and wellbeing. Care for it well and you'll enjoy a great night's sleep for many years to come.

Should you have any issues with your product please contact our customer service team on 0344 292 0000

On Delivery

Once your new bed is in place and all the packaging is removed, let it air for approximately 1 hour before putting on your mattress, mattress protector and bed linen.

Don't worry if your bed feels a little strange at first. It takes time for your body to adjust to a new level of support and comfort. You'll soon be enjoying a more relaxed sleep.

Please consider the surface your bed will be stood on. If your bed frame is to be stood on an uncarpeted surface please ensure that you use rubber backed mat under the legs to avoid slipping.

Day to day Care

Please use only 5% soap, 95% water solution, wiping with a damp cloth. Finally dry with a soft clean cloth. Dust with a soft clean cloth only.

Check all bolts, screws and legs regularly to make sure they haven't loosened and tighten all joins of your furniture or bedstead after 6 months. Please keep these instructions in a safe place for further use.

Storage Drawers in Bedsteads are designed to carry lightweight items such as Pillows, duvets and linen. Please try to avoid storing heavier items such as books or toys.

Returns

If you have bought a large item such as a bed or mattress which is damaged or faulty and would like to return it, we will be able to arrive at your home and take your item away. All we ask is that your item is in perfect condition and in its original packaging (you can open the packaging to inspect your item). Items will not be able to be returned if they are not in their original packaging.

For online and telesales orders, you can only return an item within 14 days from the date of your delivery.



www.dreams.co.uk

Thank you for purchasing from

Dreams

